

MT[®]
VALVES AND FITTINGS

CATÁLOGO CATALOGUE
INDUSTRIAL



CATÁLOGO CATALOGUE INDUSTRIAL

Introducción	2	Introduction	2
1.1 Válvulas de latón PN-40	4	1.1 Brass valves PN-40	4
1.2 Válvulas y filtros de acero inoxidable	6	1.2 Stainless steel valves and filters	6
Válvulas esfera	7	Ball valves	7
Grifos	13	Bibcock	13
Válvulas de retención	14	Non return valves	14
Válvulas de compuerta	15	Gate valves	15
Filtros	16	Filters	16
1.3 Válvulas y filtros de fundición	17	1.3 Casting valves and filters	17
Válvulas de mariposa	18	Butterfly valves	18
Válvulas de retención	25	Non return valves	25
Válvulas de compuerta	26	Gate valves	26
Válvulas esfera	27	Ball valves	27
Válvulas de globo	28	Globe valves	28
Filtros	29	Filters	29
Manguitos elásticos	30	Expansion joins	30
2.2 Accesorios y bridas de acero inoxidable	32	2.2 Stainless steel fittings and flanges	32
Sistema MT Press	33	MT Press System	33
Abarcones	42	U-bolts	42
Roscados	43	Threaded	43
Soldados	50	Welded	50
Bridas	56	Flanges	56
3 Automatización de válvulas	71	3 Valves automation	71
5 Instrumentos de medición	93	5 Measurement tools	93
9 Recambios	96	9 Spare Parts	96



CONSULTA EL **CATÁLOGO INDUSTRIAL DIGITAL** SIEMPRE ACTUALIZADO
SEE THE **DIGITAL INDUSTRIAL CATALOGUE** ALWAYS UP TO DATE

CONSULTA TODOS NUESTROS PRODUCTOS EN EL **CATÁLOGO GENERAL MT**
SEE ALL OUR PRODUCTS IN THE **MT GENERAL CATALOGUE**



BUSINESS KEY, S.L.
VERSIÓN IND-001
02-2023



MT es una multinacional española que fabrica y comercializa productos y accesorios para la canalización y conducción de fluidos en más de 40 países.

Desde 1994 MT diseña, produce y comercializa una amplia gama de productos para el segmento hidrosanitario e industrial entre los que destacan los accesorios y las válvulas de latón, accesorios de acero inoxidable, bridas y válvulas industriales, entre otros.

Con una alta cuota de mercado, MT se posiciona como una de las empresas más completas en soluciones integrales para la conducción de fluidos, segmento clave para el sector industrial, tratamientos de agua y riego, usos hidrosanitarios, automatización, instrumentación, etc.

La compañía basa su estrategia en la satisfacción del cliente con una excelente relación calidad precio en más de 5.000 referencias especialmente producidas para el profesional distribuidor.

Actualmente, MT cuenta con una red de distribuidores propios en más de 12 países, una filial en México (MT América) y clientes en más de 40 países.

MT is a spanish multinational company that manufactures and distributes products and accessories for the canalization and conduction of fluids in more than 40 countries.

Since 1994 MT has been designing, producing and marketing a wide range of products for the hydrosanitary and industrial segment, including brass valves and fittings, stainless steel fittings, flanges and industrial valves, among others.

With a nice market presence, MT is positioned as one of the most complete companies in integral solutions for the conduction of fluids, key segment for the industrial sector, water and irrigation treatments, hydrosanitary uses, automation, instrumentation, etc.

The aim of the company is the customer satisfaction, trying to give the best quality – price combination in more than 5.000 references, specially made for the professional distributor.

Nowadays, MT has a network of its own distributors in more than 12 countries, a subsidiary in Mexico (MT America) and clients in more than 40 countries.





PACK DIGITAL DE DATOS

DIGITAL DATA PACK

Pack digital de datos para distribuidores, industriales y plataformas de venta online.

En pleno proceso de digitalización, MT ha centralizado toda la información técnica y comercial de su catálogo de productos en una única y permanentemente actualizada base de datos. Se trata de la tecnología PIM (Product Information Manager).

Nuestro PIM ofrece la posibilidad de tener acceso a toda la gama de productos MT clasificada y ordenada, proporcionando esta información en los principales formatos digitales:

Digital data pack for distributors, industry and online sales platforms.

In the digitalization process, MT has centralized all the commercial and technical information of its product catalog in a unique and permanently updated database. This is known as PIM (Product Information Manager) technology.

Our PIM offers the possibility of having access to all the range of MT products classified and ordered, providing this information in the main digital formats:



BMEcat

Para canales de distribución profesionales
For channels of distribution professionals



BC3

Para prescriptores:
Presto, Cype, etc.
For prescribers:
Presto, Cype, etc.



Daterium

Suministro industrial, ferretería y materiales de construcción
Industrial Supply, Hardware and building materials stores



Go! Catalog

Plataforma del sector hidrosanitario e industrial
Digital catalog for Hydrosanitary and Industrial platforms

ACCEDE A NUESTROS CONECTORES

ACCESS TO OUR CONNECTORS

Estos formatos permiten tener un acceso rápido y fiable a una información de calidad útil para:

- Catálogos
- Puntos de venta
- Tiendas online
- Sistemas de información para ingenierías e instaladores

These formats allow fast and reliable access to quality information useful for:

- Catalogues
- Points of sale
- Online stores
- Information systems for engineering and installers

DESCARGA AQUÍ
DOWNLOAD HERE



1

VÁLVULAS Y FILTROS

VALVES AND FILTERS

1.1

LATÓN PN-40

BRASS PN-40

Rango de temperatura °C
Temperature range °C

 -20°
180°

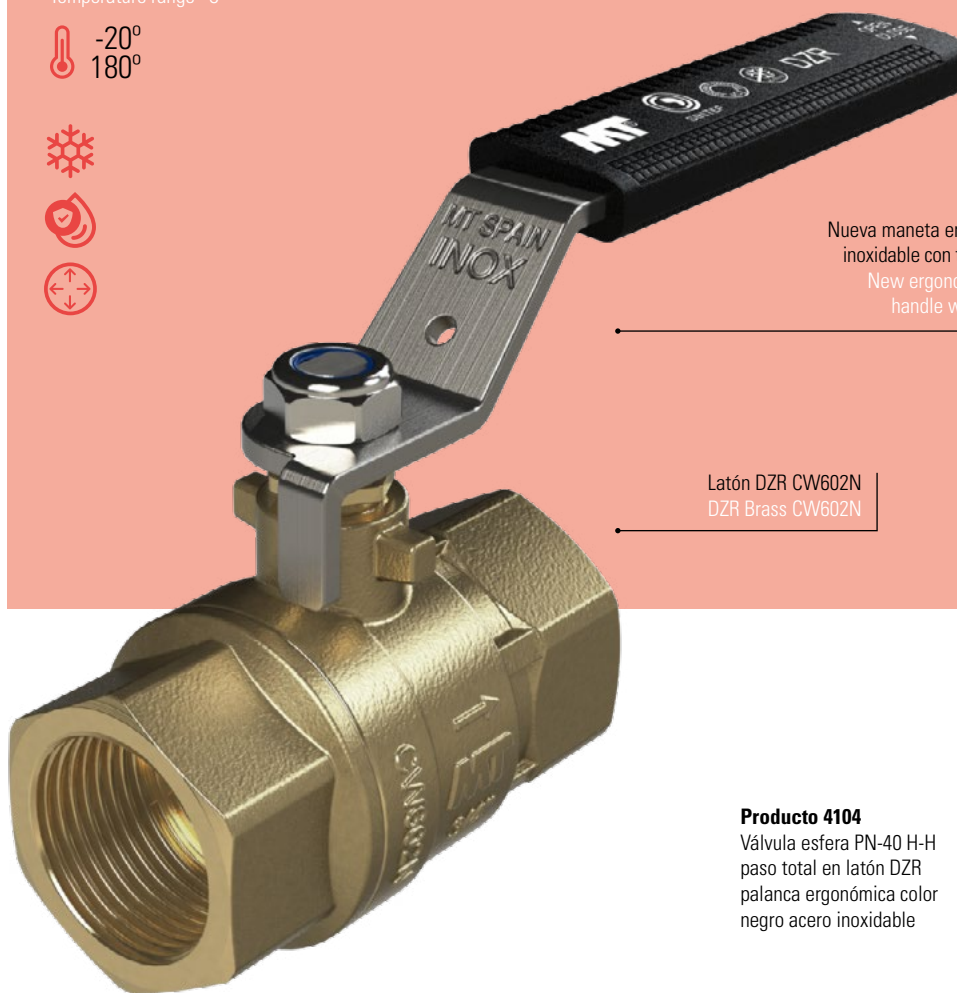

Nueva maneta ergonómica en acero inoxidable con tuerca autoblocante
New ergonomic stainless steel handle with self-locking nut

Latón DZR CW602N
DZR Brass CW602N

Producto 4104
Válvula esfera PN-40 H-H
paso total en latón DZR
palanca ergonómica color
negro acero inoxidable

Product 4104
F-F DZR brass ball valve
PN-40 full bore with black
ergonomic stainless steel
handle



PLATINUM SERIES

- Paso total
- Sistema Antihielo
- Cuerpo reforzado
- Latón DZR CW602N
- Eje en acero inoxidable
- Nueva maneta ergonómica en acero inoxidable con tuerca autoblocante. Alta resistencia frente a la corrosión
- Juntas en FKM
- -20°C / 180°C
- Full bore
- Nofrost System
- Reinforced body
- DZR Brass CW602N
- Stainless steel stem
- New ergonomic stainless steel handle with self-locking nut. High protection from corrosion
- FKM o-rings
- -20°C / 180°C

PN
40

• **Recambios** disponibles en página 97
Spare parts available page 97



CÓDIGO CODE _____
MEDIDA SIZE _____
ENCAJADO GRANDE MASTER CARTON _____
ENCAJADO INTERMEDIO INNER CARTON _____

4104



Válvula esfera PN-40 H-H paso total en latón DZR palanca ergonómica color negro acero inoxidable

F-F DZR brass ball valve PN-40 full bore with black ergonomic stainless steel handle

PLATINUM
DZR SINTEF ACS
ANTIHIELO / NOFROST EAN CODE

CÓDIGO CODE	MEDIDA SIZE	ENCAJADO GRANDE MASTER CARTON	ENCAJADO INTERMEDIO INNER CARTON
4104-015	1/2"	48	12
4104-020	3/4"	32	8
4104-025	1"	20	5
4104-032	1 1/4"	12	3
4104-040	1 1/2"	12	2
4104-050	2"	12	2



FICHA TÉCNICA
TECHNICAL SHEET

4504



Válvula esfera PN-40 M-H paso total en latón DZR palanca ergonómica color negro acero inoxidable

M-F DZR brass ball valve PN-40 full bore with black ergonomic stainless steel handle

PLATINUM
DZR SINTEF ACS
ANTIHIELO / NOFROST EAN CODE

4504-015	1/2"	40	10
4504-020	3/4"	24	6
4504-025	1"	16	4
4504-032	1 1/4"	12	3
4504-040	1 1/2"	12	2
4504-050	2"	12	1



FICHA TÉCNICA
TECHNICAL SHEET

4204



Válvula esfera PN-40 H-H paso total en latón DZR mando palomilla color negro

F-F DZR brass ball valve PN-40 full bore with black butterfly handle

PLATINUM
DZR SINTEF ACS
ANTIHIELO / NOFROST EAN CODE

4204-015	1/2"	60	15
4204-020	3/4"	44	11
4204-025	1"	28	7



FICHA TÉCNICA
TECHNICAL SHEET

4604



Válvula esfera PN-40 M-H paso total en latón DZR mando palomilla color negro

M-F DZR brass ball valve PN-40 full bore with black butterfly handle

PLATINUM
DZR SINTEF ACS
ANTIHIELO / NOFROST EAN CODE

4604-015	1/2"	60	15
4604-020	3/4"	44	11
4604-025	1"	28	7



FICHA TÉCNICA
TECHNICAL SHEET

1

VÁLVULAS
Y FILTROS

VALVES AND FILTERS

1.2

ACERO INOXIDABLE

STAINLESS STEEL

Aplicaciones

Instalaciones de agua fría y caliente, vapor baja presión, instalaciones químicas, disolventes, fluidos de todo tipo y aire. Industrias químicas, industrias petroquímicas, industrias alimentarias para proceso externas y auxiliares. Conducción de fluidos, calderas, intercambiadores de calor.

Applications

Installations of cold and hot water, low pressure steam, chemical installations, solvents, fluids and air. Chemical industries, petrochemical industries, food industries for external and auxiliary process. Fluid conduction, boilers, heat exchangers.

Rango de temperatura °C

Temperature range °C

 -20°
180°
Calidad

AISI 316/316L

WCB - Acero al carbono

Paso total o reducido

Quality

AISI 316/316L

WCB - Carbon steel

Full bore or reduced bore



Acero inoxidable CF8M (AISI-316)
Stainless steel CF8M (AISI-316)

Producto 0912

Válvula esfera tres piezas
rosca paso total pletina
ISO de acero inoxidable

Product 0912

Three pieces ball valve
threaded end full bore, top
flange ISO



Management
System
ISO 9001:2015



www.tuv.com
ID 9108643013

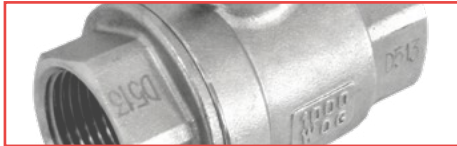

VÁLVULAS ESFERA BALL VALVES

CÓDIGO CODE _____
MEDIDA SIZE _____
ENCAJADO GRANDE MASTER CARTON _____
ENCAJADO INTERMEDIO INNER CARTON _____

0909



Válvula esfera una pieza
roscar paso reducido BSP

- Cuerpo y bola acero inoxidable CF8M (AISI-316)
- Asientos bola en PTFE
- Roscas H-H BSP s/ norma ISO 7-1
- Presión máxima de trabajo: 63 Bar (1000 psi)
- Temperatura de trabajo: -20°C / 180°C
- Paso reducido

Ball valve one piece thread-
end reduced bore BSP

- Body and ball made of stainless steel CF8M (AISI-316)
- PTFE ball seats
- F-F BSP Threads ISO 7-1
- Max. working pressure: 63 Bar (1000 psi)
- Working temperature: -20°C / 180°C
- Reduced bore

0909-008	1/4"	100	50
0909-010	3/8"	60	30
0909-015	1/2"	50	25
0909-020	3/4"	36	18
0909-025	1"	24	12



FICHA TÉCNICA
TECHNICAL SHEET

09102

0910



Válvula de dos piezas
roscar H-H

- Cuerpo y bola acero inoxidable CF8M (AISI-316)
- Asientos bola en PTFE
- Roscas H-H BSP s/ norma ISO 7/1
- Presión máxima de trabajo: 63 Bar (1000 psi)
- Temperatura de trabajo: -20°C / 180°C
- Paso total

F-F Ball valve two pieces
threaded end full bore

- Body and ball made of stainless steel CF8M (AISI-316)
- PTFE ball seats
- F-F BSP Threads ISO 7/1
- Max. Working pressure: 63 Bar (1000 psi)
- Working temperature: -20°C / 180°C
- Full bore

09102-008	0910-008	1/4"	48	24
09102-010	0910-010	3/8"	48	24
09102-015	0910-015	1/2"	32	16
09102-020	0910-020	3/4"	24	12
09102-025	0910-025	1"	16	8
09102-032	0910-032	1 1/4"	10	1
09102-040	0910-040	1 1/2"	10	1
09102-050	0910-050	2"	6	1
09102-065	0910-065	2 1/2"	4	1
09102-080	0910-080	3"	3	1



FICHA TÉCNICA
TECHNICAL SHEET

09104

09103



Válvula de dos piezas
roscar M-H

- Cuerpo y bola acero inoxidable CF8M (AISI-316)
- Asientos bola en PTFE
- Roscas M-H BSP s/ norma ISO 7/1
- Presión máxima de trabajo: 63 Bar (1000 psi)
- Temperatura de trabajo: -20°C / 180°C
- Paso total

M-F Ball valve two pieces
threaded end full bore

- Body and ball made of stainless steel CF8M (AISI-316)
- PTFE ball seats
- M-F BSP threads ISO 7/1
- Max. working pressure: 1000 psi wog (PN-63)
- Working temperature: -20°C / 180°C
- Full bore

09104-008	09103-008	1/4"	48	24
09104-010	09103-010	3/8"	48	24
09104-015	09103-015	1/2"	32	16
09104-020	09103-020	3/4"	24	12
09104-025	09103-025	1"	16	8
09104-032	09103-032	1 1/4"	10	1
09104-040	09103-040	1 1/2"	10	1
09104-050	09103-050	2"	3	1
09104-065	09103-065	2 1/2"	4	1
09104-080	09103-080	3"	3	1
09104-100	09103-100	4"	2	1



FICHA TÉCNICA
TECHNICAL SHEET

CÓDIGO CODE _____
MEDIDA SIZE _____
ENCAJADO GRANDE MASTER CARTON _____
ENCAJADO INTERMEDIO INNER CARTON _____

0917



Válvula esfera dos piezas roscar plataforma de montaje

- Cuerpo y bola acero inoxidable CF8M (AISI-316)
- Asientos bola en PTFE
- Roscas H-H BSP s/ norma ISO 228 (DIN 259)
- Plataforma montaje directo ISO 5211
- Presión máxima de trabajo: 63 Bar (1000 psi)
- Temperatura de trabajo: -20°C / 180°C
- Paso total

Ball valve two pieces with mounting pad full bore threaded end

- Body and ball made of stainless steel CF8M (AISI-316)
- PTFE ball seats
- F-F BSP Threads ISO 228 (DIN 259)
- Direct mounting Pad ISO 5211
- Max. Working pressure: 63 Bar (1000 psi)
- Working temperature: -20°C / 180°C
- Full bore

0917-008	1/4"	80	40
0917-010	3/8"	80	40
0917-015	1/2"	24	12
0917-020	3/4"	20	10
0917-025	1"	12	6
0917-032	1 1/4"	10	5
0917-040	1 1/2"	4	2
0917-050	2"	3	1

• Para automatización, consultar capítulo 3
See automation valves on chapter 3



FICHA TÉCNICA
TECHNICAL SHEET

0911



Válvula esfera de tres piezas paso total

- Cuerpo fabricado en acero inoxidable CF8M (AISI-316)
- Bola fabricada en acero inoxidable CF8M (AISI-316)
- Asientos bola en PTFE reforzado
- Roscas H-H BSP s/ norma ISO 228/1 (DIN 259)
- Paso total
- Presión máxima de trabajo: 63 Bar (1000 psi)
- Temperatura de trabajo: -20°C / 180°C

Three pieces stainless steel ball valve

- Body made of stainless steel CF8M (AISI-316)
- CF8M (AISI-316) stainless steel ball
- Reinforced PTFE ball seats
- F-F BSP Threads ISO 228/1 (DIN 259)
- Full bore
- Max. Working pressure: 63 Bar (1000 psi)
- Working temperature: -20°C / 180°C

0911-008	1/4"	36	18
0911-010	3/8"	36	18
0911-015	1/2"	20	10
0911-020	3/4"	16	8
0911-025	1"	16	8
0911-032	1 1/4"	8	1
0911-040	1 1/2"	6	1
0911-050	2"	3	1
0911-065	2 1/2"	3	1
0911-080	3"	2	1
0911-100	4"	2	1



FICHA TÉCNICA
TECHNICAL SHEET

0912



Válvula esfera tres piezas roscar paso total pletina ISO

- Cuerpo fabricado en acero inoxidable CF8M (AISI-316)
- Bola fabricada en acero inoxidable CF8M (AISI-316)
- Asientos bola en PTFE reforzado
- Roscas H-H BSP s/ norma ISO 228/1 (DIN 2599)
- Plataforma montaje directo ISO 5211
- Paso total
- Presión máxima de trabajo: 63-40 Bar (1000-600 psi)
- Temperatura de trabajo: -20°C / 180°C

Three pieces ball valve threaded end full bore, top flange ISO

- Body made of stainless steel CF8M (AISI-316)
- CF8M (AISI-316) stainless steel ball
- Reinforced PTFE ball seats
- F-F BSP Threads ISO 228/1 (DIN 2599)
- Direct mounting Pad ISO 5211
- Full bore
- Max. working pressure: 63-40 Bar (1000-600 psi)
- Working temperature: -20°C / 180°C

0912-008*	1/4"	16	8
0912-010*	3/8"	16	8
0912-015*	1/2"	16	8
0912-020*	3/4"	16	8
0912-025*	1"	8	4
0912-032*	1 1/4"	6	1
0912-040*	1 1/2"	4	1
0912-050**	2"	3	1
0912-065**	2 1/2"	3	1
0912-080**	3"	2	1
0912-100**	4"	1	1

* 63 bar - 1000 psi
** 40 bar - 600 psi

• Para automatización, consultar capítulo 3
See automation valves on chapter 3



FICHA TÉCNICA
TECHNICAL SHEET

CÓDIGO CODE _____
MEDIDA SIZE _____

ENCAJADO GRANDE MASTER CARTON _____
ENCAJADO INTERMEDIO INNER CARTON _____

91020



Válvula esfera tres piezas
Butt Weld paso total pletina ISO

- Cuerpo y bola acero inoxidable CF8M (AISI-316)
- Asientos bola en PTFE reforzado
- Plataforma montaje directo ISO5211
- Presión máxima de trabajo: 63-40 Bar (1000-600 psi)
- Temperatura de trabajo: -20°C / 180°C
- Paso total

Three pieces ball valve Butt Weld full bore mounting pad ISO

- Body and ball made of stainless steel CF8M (AISI-316)
- Reinforced PTFE ball seats
- Direct mounting Pad ISO 5211
- Max. working pressure: 63-40 Bar (1000-600 psi)
- Working temperature: -20°C / 180°C
- Full bore

91020-015*	1/2"	16	8
91020-020*	3/4"	16	8
91020-025*	1"	8	4
91020-032*	1 1/4"	6	1
91020-040*	1 1/2"	4	1
91020-050**	2"	3	1
91020-065**	2 1/2"	3	1

- * 63 bar - 1000 psi
- ** 40 bar - 600 psi

• Para automatización, consultar capítulo 3
See automation valves on chapter 3



FICHA TÉCNICA
TECHNICAL SHEET

91120



Válvula esfera tres piezas
Socket Weld paso total pletina ISO

- Cuerpo y bola acero inoxidable CF8M (AISI-316)
- Asientos bola en PTFE reforzado
- Plataforma montaje directo ISO5211
- Presión máxima de trabajo: 63-40 Bar (1000-600 psi)
- Temperatura de trabajo: -20° / 180°C
- Paso total

Three pieces ball valve Socket Weld full bore mounting pad ISO

- Body and ball made of stainless steel CF8M (AISI-316)
- Reinforced PTFE ball seats
- Direct mounting Pad ISO 5211
- Max. Working pressure: 63-40 Bar (1000-600 psi)
- Working temperature: -20° / 180°C
- Full bore

91120-015*	1/2"	16	8
91120-020*	3/4"	16	8
91120-025*	1"	8	4
91120-032*	1 1/4"	6	1
91120-040*	1 1/2"	4	1
91120-050**	2"	3	1
91120-065**	2 1/2"	3	1
91120-080**	3"	2	1
91120-100**	4"	1	1

- * 63 bar - 1000 psi
- ** 40 bar - 600 psi

• Para automatización, consultar capítulo 3
See automation valves on chapter 3



FICHA TÉCNICA
TECHNICAL SHEET

0918



Válvula esfera tres vías
pletina ISO paso en L

- Cuerpo fabricado en acero inoxidable CF8M (AISI-316)
- Bola fabricada en acero inoxidable CF8M (AISI-316)
- Asientos bola en PTFE
- Roscas H-H BSP s/ norma ISO 228 (DIN 259)
- Esfera con paso en L
- Plataforma de montaje ISO5211
- Presión máxima de trabajo: 63 Bar (1000 psi)
- Temperatura de trabajo: -20°C / 180°C
- Paso reducido

Three way ball valve L-type with mounting pad ISO

- Body made of stainless steel CF8M (AISI-316)
- CF8M (AISI-316) stainless steel ball
- PTFE ball seats
- F-F BSP Threads ISO 228 (DIN 259)
- L-Type bore ball
- Direct mounting pad ISO5211
- Max. working pressure: 63 Bar (1000 psi)
- Working temperature: -20°C / 180°C
- Reduced bore

0918-008	1/4"	8	4
0918-010	3/8"	8	4
0918-015	1/2"	8	4
0918-020	3/4"	8	4
0918-025	1"	4	2
0918-032	1 1/4"	5	1
0918-040	1 1/2"	3	1
0918-050	2"	2	1

• Para automatización, consultar capítulo 3
See automation valves on chapter 3



FICHA TÉCNICA
TECHNICAL SHEET

CÓDIGO CODE _____
MEDIDA SIZE _____
ENCAJADO GRANDE MASTER CARTON _____
ENCAJADO INTERMEDIO INNER CARTON _____

0919



Válvula esfera tres vías
pletina ISO paso en T

Three way ball valve t-type
with mounting pad ISO

- Cuerpo fabricado en acero inoxidable CF8M (AISI-316)
 - Bola fabricada en acero inoxidable CF8M (AISI-316)
 - Asientos bola en PTFE
 - Roscas H-H BSP s/ norma ISO 228 (DIN 259)
 - Esfera con paso en T
 - Plataforma de montaje ISO5211
 - Presión máxima de trabajo: 63 Bar (1000 psi)
 - Temperatura de trabajo: -20°C / 180°C
 - Paso reducido
- Body made of stainless steel CF8M (AISI-316)
 - CF8M (AISI-316) stainless steel ball
 - PTFE ball seats
 - F-F BSP Threads ISO 228 (DIN 259)
 - T-Type bore ball
 - Direct mounting pad ISO5211
 - Max. working pressure: 63 Bar (1000 psi)
 - Working temperature: -20°C / 180°C
 - Reduced bore

0919-008	1/4"	8	4
0919-010	3/8"	8	4
0919-015	1/2"	8	4
0919-020	3/4"	8	4
0919-025	1"	4	2
0919-032	1 1/4"	5	1
0919-040	1 1/2"	3	1
0919-050	2"	2	1

• Para automatización, consultar capítulo 3
See automation valves on chapter 3



FICHA TÉCNICA
TECHNICAL SHEET

CÓDIGO CODE _____
MEDIDA SIZE _____
ENCAJADO GRANDE MASTER CARTON _____
ENCAJADO INTERMEDIO INNER CARTON _____

09142 ■

0914 ■



Válvula esfera mini paso
reducido PN-63 H-H

F-F Reduced bore ball valve
PN-63

- Cuerpo fabricado en acero inoxidable CF8M (AISI-316)
 - Bola fabricada en acero inoxidable CF8M (AISI-316)
 - Asientos bola en PTFE
 - Rosca S/ ISO 7-1
 - Presión máxima de trabajo: 63 Bar (PN-63)
 - Temperatura de trabajo: -20°C / 180°C
- Body made of stainless steel CF8M (AISI-316)
 - CF8M (AISI-316) stainless steel ball
 - PTFE ball seats
 - Thread according to ISO 7-1
 - Max. working pressure: 63 Bar (PN-63)
 - Working temperature: -20°C / 180°C

09142-008	0914-008	1/4"	120	60
09142-010	0914-010	3/8"	120	60
09142-015	0914-015	1/2"	100	50



FICHA TÉCNICA
TECHNICAL SHEET

09152 ■

0915 ■



Válvula esfera mini paso
reducido PN-63 M-H

M-F Reduced bore ball
valve PN-63

- Cuerpo fabricado en acero inoxidable CF8M (AISI-316)
 - Bola fabricada en acero inoxidable CF8M (AISI-316)
 - Asientos bola en PTFE
 - Rosca S/ ISO 7-1
 - Presión máxima de trabajo: 63 Bar (PN-63)
 - Temperatura de trabajo: -20°C / 180°C
- Body made of stainless steel CF8M (AISI-316)
 - CF8M (AISI-316) stainless steel ball
 - PTFE ball seats
 - Thread according to ISO 7-1
 - Max. working pressure: 63 Bar (PN-63)
 - Working temperature: -20°C / 180°C

09152-008	0915-008	1/4"	120	60
09152-010	0915-010	3/8"	120	60
09152-015	0915-015	1/2"	100	50



FICHA TÉCNICA
TECHNICAL SHEET

CÓDIGO CODE _____
MEDIDA SIZE _____
ENCAJADO GRANDE MASTER CARTON _____
ENCAJADO INTERMEDIO INNER CARTON _____

5128



Válvula esfera dos piezas
inoxidable brida

ATEX

- Cuerpo en acero inoxidable CF8M (AISI-316)
- Bola en acero inoxidable CF8M (AISI-316)
- Asientos de bola de PTFE + grafito
- Juntas en PTFE + grafito
- Diseño S/ DIN 3202 con dispositivo de protección contra incendios
- Juntas tóricas eje FKM
- Bridas EN-1092 PN-16
- Presión máxima de trabajo: 16 Bar
- Temperatura de trabajo: -20°C / 180°C
- Paso total
- Certificado ATEX

Two pieces ball valve stain-
less steel flanged end

- Body made of stainless steel CF8M (AISI-316)
- CF8M (AISI-316) stain-
less steel ball
- Ball seats PTFE +
graphite
- PTFE + graphite seat
gaskets
- Design to DIN 3202 with
fire safe system
- FKM stem O-rings
- Flanges EN-1092-2
PN-16
- Max. pressure: 16 bar
- Working temperature:
-20°C / 180°C
- Full bore
- ATEX certificate

5128-015*	1/2"	18	-
5128-020*	3/4"	15	-
5128-025*	1"	1	-
5128-032*	1 1/4"	1	-
5128-040*	1 1/2"	1	-
5128-050**	2"	1	-
5128-065**	2 1/2"	1	-
5128-080**	3"	1	-
5128-100**	4"	1	-
5128-125**	5"	1	-
5128-150**	6"	1	-
5128-200**	8"	1	-

PN-40*/16** (bridas flanges)

- Para automatización, consultar capítulo 3
See automation valves on chapter 3



FICHA TÉCNICA
TECHNICAL SHEET

5117



Válvula esfera dos piezas
acero al carbono con bridas

- Cuerpo fabricado en acero al carbono (A-276 WCB)
- Bola fabricada en acero inoxidable
- Asientos de bola de PTFE reforzado con grafito
- Juntas tóricas eje FKM
- Bridas s/ UNE EN-1092-2 PN-16
- Presión máxima de trabajo: 16 Bar
- Temperatura de trabajo: -20°C / 180°C
- Paso total

Two pieces ball valve WCB
flanged end

- Body made of carbon steel (A-276 WCB)
- Stainless steel ball
- Ball seats made of reinforced PTFE with graphite
- FKM stem O-rings
- Flanges according to UNE EN-1092-2 PN-16
- Max. working pressure: 16 Bar
- Working temperature: -20°C / 180°C
- Full bore

5117-015*	1/2"	18	-
5117-020*	3/4"	15	-
5117-025*	1"	1	-
5117-032*	1 1/4"	1	-
5117-040*	1 1/2"	1	-
5117-050**	2"	1	-
5117-065**	2 1/2"	1	-
5117-080**	3"	1	-
5117-100**	4"	1	-
5117-125**	5"	1	-
5117-150**	6"	1	-

PN-40*/16** (bridas flanges)

- Para automatización, consultar capítulo 3
See automation valves on chapter 3



FICHA TÉCNICA
TECHNICAL SHEET

CÓDIGO CODE
MEDIDA SIZE

ENCAJADO GRANDE MASTER CARTON
ENCAJADO INTERMEDIO INNER CARTON

91031



Válvula esfera wafer paso total con pletina ISO

- Cuerpo y bola acero inoxidable CF8M (AISI-316)
- Asientos bola en PTFE
- Juntas tóricas de FKM
- Brida EN-1092
- Plataforma de montaje ISO 5211
- Presión máxima de trabajo: 16 Bar
- Temperatura de trabajo: -20°C / 180°C

Wafer full bore ball valve with mounting pad ISO

- Body and ball made of stainless steel CF8M (AISI-316)
- PTFE ball seats
- FKM O-rings
- EN-1092 flanges
- Direct mounting pad ISO 5211
- Max. working pressure: 16 Bar
- Working temperature: -20°C / 180°C

91031-015	1/2"	18	9
91031-020	3/4"	14	7
91031-025	1"	12	6
91031-032	1 1/4"	6	3
91031-040	1 1/2"	1	1
91031-050	2"	1	1
91031-065	2 1/2"	1	1
91031-080	3"	1	1
91031-100	4"	1	1

• Para automatización, consultar capítulo 3
See automation valves on chapter 3



FICHA TÉCNICA
TECHNICAL SHEET

91032



Válvula esfera wafer paso total con pletina ISO con cámara calefacción

- Cuerpo y bola acero inoxidable CF8M (AISI-316)
- Asientos bola en PTFE
- Juntas tóricas de FKM
- Cámara de calefacción INOX. (AISI-316)
- Tomas 3/4" hembra
- Brida EN-1092
- Plataforma de montaje ISO 5211
- Presión máxima de trabajo: 16 Bar
- Temperatura de trabajo: -20°C / 180°C

Wafer full bore ball valve with mounting pad ISO and heat chamber

- Body and ball made of stainless steel CF8M (AISI-316)
- PTFE ball seats
- FKM O-rings
- Heat chamber of S.S. (AISI-316)
- Head threads 3/4" female
- EN-1092 flanges
- Direct mounting pad ISO 5211
- Max. working pressure: 16 Bar
- Working temperature: -20°C / 180°C

91032-015	1/2"	1	1
91032-020	3/4"	1	1
91032-025	1"	1	1
91032-032	1 1/4"	1	1
91032-040	1 1/2"	1	1
91032-050	2"	1	1
91032-065	2 1/2"	1	1
91032-080	3"	1	1
91032-100	4"	1	1

• Para automatización, consultar capítulo 3
See automation valves on chapter 3



FICHA TÉCNICA
TECHNICAL SHEET



GRIFOS BIBCOCK

CÓDIGO CODE _____
MEDIDA SIZE _____
ENCAJADO GRANDE MASTER CARTON _____
ENCAJADO INTERMEDIO INNER CARTON _____

0926



Válvula barril para depósito

- Cuerpo y maneta en acero inoxidable AISI-316
- Asientos en PTFE
- Tuerca para soldar incluida
- Presión máxima de trabajo: 6 Bar (100 psi)
- Temperatura de trabajo: -20°C /180°C

Barrel ball valve

- Body and handle made of stainless steel AISI-316
- PTFE seats
- Welding nut included
- Max. working pressure: 6 Bar (100 psi)
- Working temperature: -20°C /180°C

0926-008	1/4"	100	50
----------	------	-----	----



FICHA TÉCNICA
TECHNICAL SHEET

0921



0921G



Grifo esfera jardín enchufe manguera PN-16 inoxidable

EAN CODE

- Cuerpo, tapa, bola y conexión manguera en acero inoxidable AISI-316
- Maneta y mecanismo de bloqueo en AISI-304
- Asientos bola en PTFE
- Rosca s/ ISO 228/1 (DIN 259)
- Presión máxima de trabajo: 16 Bar
- Temperatura de trabajo: -10°C /100°C

Stainless steel bib cock garden PN-16 hose connector

- Body, bonnet, ball and hose connection made of stainless steel AISI-316
- Handle and lock device made of stainless steel AISI-304
- PTFE ball seats
- Thread according to ISO 228/1 (DIN259)
- Max. working pressure: 16 Bar
- Working temperature: -10°C / 100°C

0921-015	1/2" x 3/4"	30	15
0921-015G	1/2" x 3/4"	12	1
0921-020	3/4" x 3/4"	20	10
0921-025	1" x 1"	10	5



FICHA TÉCNICA
TECHNICAL SHEET



VÁLVULAS DE RETENCIÓN NON RETURN VALVES

CÓDIGO CODE _____

MEDIDA SIZE _____

ENCAJADO GRANDE MASTER CARTON _____

ENCAJADO INTERMEDIO INNER CARTON _____

0916



Válvula de retención dos piezas

- Cuerpo, tapa y disco fabricado en acero inoxidable CF8M (AISI-316)
- Junta cierre en PTFE
- Asiento en FKM
- Roscas s/ norma ISO 7/1
- Presión mínima de apertura: 0,5 Bar
- Presión máxima de trabajo: 16 Bar
- Temperatura de trabajo: -20°C / 180°C

Two pieces spring vertical check valve

- Body, cap and press cap made of stainless steel CF8M (AISI-316)
- PTFE gasket
- FKM seat
- Thread ends according to ISO 7/1
- Minimum pressure to open: 0,5 Bar
- Max. working pressure: 16 Bar
- Working temperature: -20°C / 180°C

0916-008	1/4"	100	50
0916-010	3/8"	100	50
0916-015	1/2"	70	35
0916-020	3/4"	54	27
0916-025	1"	34	17
0916-032	1 1/4"	20	10
0916-040	1 1/2"	20	10
0916-050	2"	12	6
0916-065	2 1/2"	7	1
0916-080	3"	6	1
0916-100	4"	3	1



FICHA TÉCNICA
TECHNICAL SHEET

5118



Válvula de retención disco PN-40

- Fabricada completamente en inoxidable CF8M (AISI-316)
- Bridas s/ norma DIN 2501 / EN-1092:1 PN-40
- Cara a cara s/ norma DIN 3202-1999 K4
- Presión máxima de trabajo: 40 Bar
- Temperatura de trabajo: -20°C / 300°C
- Paso reducido

Disc check valve PN-40

- Made completely of stainless steel CF8M (AISI-316)
- Flanges according to DIN 2501 / EN-1092:1 PN-40
- Face to face according to DIN 3202-1999 K4
- Max. working pressure: 40 Bar
- Working temperature: -20°C / 300°C
- Reduced bore

5118-015	1/2"	1	-
5118-020	3/4"	1	-
5118-025	1"	1	-
5118-032	1 1/4"	1	-
5118-040	1 1/2"	1	-
5118-050	2"	1	-
5118-065	2 1/2"	1	-
5118-080	3"	1	-
5118-100	4"	1	-



FICHA TÉCNICA
TECHNICAL SHEET

5119



Válvula de retención clape-
ta oscilante tipo wafer

- Cuerpo y disco inoxidable 316 (AISI-316)
- Juntas de FKM
- Bridas s/ norma EN-1092 PN-10/16 (DIN-2501/2502)
- Presión máxima de trabajo: 16 Bar
- Temperatura de trabajo: -20°C / 180°C
- Paso reducido

Thin wafer swing check valve

- Body and disc made of stainless steel 316 (AISI-316)
- FKM O-Rings
- Flanges according to EN-1092 PN-10/16 (DIN-2501/2502)
- Max. working pressure: 16 Bar
- Working temperature: -20°C / 180°C
- Reduced bore

5119-040	1 1/2"	1	1
5119-050	2"	1	1
5119-065	2 1/2"	1	1
5119-080	3"	1	1
5119-100	4"	1	1
5119-125	5"	1	1
5119-150	6"	1	1



FICHA TÉCNICA
TECHNICAL SHEET



VÁLVULAS DE COMPUERTA GATE VALVES

CÓDIGO CODE _____
MEDIDA SIZE _____
ENCAJADO GRANDE MASTER CARTON _____

5132



Válvula de compuerta inoxidable cierre metálico

- Fabricado en acero inoxidable (AISI-316)
- Compuerta metálica INOX AISI-316
- Eje de acero inoxidable (AISI-316)
- Bridas s/ UNE EN1092-2 PN-16
- Presión máxima de trabajo: 16 Bar
- Temperatura de trabajo: -20°C / 200°

Metallic gate valve stainless steel

- Made of stainless steel (AISI-316)
- Stainless steel wedge AISI-316
- Stainless steel stem (AISI-316)
- Flanges according to UNE EN1092-2 PN-16
- Max. working pressure: 16 Bar
- Working temperature: -20°C / 200°C

5132-040	1 1/2"	1
5132-050	2"	1
5132-065	2 1/2"	1
5132-080	3"	1
5132-100	4"	1
5132-125	5"	1
5132-150	6"	1
5132-200	8"	1

- Bajo consulta
On request



 FICHA TÉCNICA
TECHNICAL SHEET

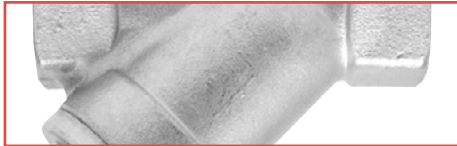

FILTROS FILTERS

CÓDIGO CODE _____
 MEDIDA SIZE _____
 ENCAJADO GRANDE MASTER CARTON _____
 ENCAJADO INTERMEDIO INNER CARTON _____

0913

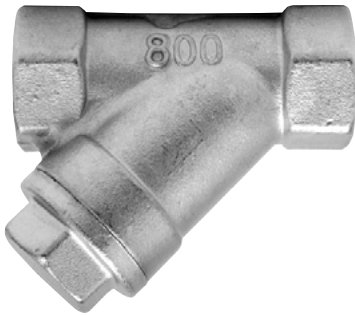

Filtro A-316 Y tamiz inoxidable conexión H-H

- Fabricado en inoxidable CF8M (AISI-316)
- Junta plana de PTFE
- Grado de filtración: 1mm.
- Roscas s/ norma ISO 7/1 (DIN 2999/BS 21)
- Presión máxima de trabajo: 40 Bar
- Temperatura de trabajo: -20°C / 180°C

F-F stainless steel A-316 Y strainer filter

- Made of stainless steel CF8M (AISI-316)
- Flat PTFE gasket
- Filtration degree: 1mm.
- F-F threads according to ISO 7/1 (DIN 2999/BS 21)
- Max. working pressure: 40 Bar
- Working temperature: -20°C / 180°C

0913-008	1/4"	70	35
0913-010	3/8"	70	35
0913-015	1/2"	40	20
0913-020	3/4"	30	15
0913-025	1"	16	8
0913-032	1 1/4"	18	9
0913-040	1 1/2"	12	6
0913-050	2"	6	1



 FICHA TÉCNICA
TECHNICAL SHEET

1

VÁLVULAS Y FILTROS

VALVES AND FILTERS

Rango de temperatura °C
Temperature range °C

 -20°
120°

1.3

FUNDICIÓN

CASTING



Aplicaciones

Calefacción, ventilación y aire acondicionado.
Tratamiento y sistemas de distribución de agua.
Industria de la minería.
Construcciones navales.
Plantas químicas y petroquímicas.
Industria azucarera.
Procesos químicos y alimetación.
Gas y aceite.
Sistemas contra incendios.
Sistemas sanitarios.

Applications

Heating, air conditioning and ventilating.
Water treatment and distribution systems.
Mining industry.
Shipbuilding and off-shore industries.
Chemical and petrochemical plants.
Sugar industry.
Food and chemistry processing.
Oil and gas.
Fire fighting systems.
Sanitary systems.

Producto 5114

Válvula de mariposa tipo Wafer
disco inoxidable
asiento blando EPDM

Product 5114

Butterfly valve wafer type
stainless steel disc
EPDM soft seat



VÁLVULAS DE MARIPOSA BUTTERFLY VALVES

CÓDIGO CODE
MEDIDA SIZE

5114



Válvula de mariposa tipo wafer disco inoxidable asiento blando EPDM

- Fabricado en fundición Nodular GGG-40 (GJS-400)
- Recubrimiento en pintura Epoxy RAL5013
- Disco acero inoxidable AISI-316
- Diseño s/ EN-12334, DIN 3202, EN 558-1
- Bridas s/ UNE EN-1092-2 PN6-10-PN16 Ansi B16.5 Clase 125/150
- Presión máxima de trabajo: 2"-10": 16 Bar (250PSI) 12": 10 Bar
- Temperatura de trabajo: -20°C/120°C

Butterfly valve wafer type stainless steel disc EPDM soft seat

- Made of ductile Iron GGG-40 (GJS-400)
- Epoxy coating Epoxy RAL5013
- Stainless steel disc AISI-316
- Design according to EN-12334, DIN 3202, EN 558-1
- Flanges according to UNE EN-1092-2 PN6-10-PN16 Ansi B16.5 Class 125/150
- Working pressure (Max): 2"-10": 16 Bar (250PSI) 12": 10 Bar
- Working temperature: -20°C / 120°C

5114-040	1 1/2"
5114-050	2"
5114-065	2 1/2"
5114-080	3"
5114-100	4"
5114-125	5"
5114-150	6"
5114-200	8"
5114-250	10"

- Para automatización, consultar capítulo 3
See automation valves on chapter 3



FICHA TÉCNICA
TECHNICAL SHEET

5114MR



Válvula de mariposa tipo wafer asiento blando EPDM reductor manual

- Fabricado en fundición Nodular GGG-40 (GJS-400)
- Recubrimiento en pintura Epoxy RAL5013
- Epoxy coating RAL5013
- Disco acero inoxidable AISI-316
- Asiento elastómero EPDM asiento blando
- Diseño s/ EN-12334, DIN 3202, EN 558-1
- Bridas s/ UNE EN-1092-2 PN6-10-PN16 Ansi B16.5 Clase 125/150
- Presión máxima de trabajo: 2"-12": 16 Bar (250PSI)
- Temperatura de trabajo: -20°C / 120°C

Butterfly valve wafer type EPDM soft seat gear operator

- Made of ductile Iron GGG-40 (GJS-400)
- Epoxy coating RAL5013
- Stainless steel disc AISI-316
- EPDM seat gasket soft seat
- Design according to EN-12334, DIN 3202, EN 558-1
- Flanges according to UNE EN-1092-2 PN6-10-PN16 Ansi B16.5 Class 125/150
- Working pressure (Max): 2"-12": 16 Bar (250PSI) 14"-24": 10 Bar (150PSI)
- Working temperature: -20°C / 120°C

5114-050MR	2"
5114-065MR	2 1/2"
5114-080MR	3"
5114-100MR	4"
5114-125MR	5"
5114-150MR	6"
5114-200MR	8"
5114-250MR	10"
5114-300MR	12"
5114-350MR	14"
5114-400MR	16"
5114-500MR	20"
5114-600MR	24"



FICHA TÉCNICA
TECHNICAL SHEET

CÓDIGO CODE _____
MEDIDA SIZE _____

51142



Válvula de mariposa tipo wafer disco inoxidable asiento blando NBR

- Fabricado en fundición Nodular GGG-40 (GJS-400)
- Recubrimiento en pintura Epoxy RAL5013
- Disco acero inoxidable AISI-316
- Asiento en NBR
- Diseño s/ EN-12334, DIN 3202, EN 558-1
- Bridas s/ UNE EN-1092-2 PN6-10-16 Ansi B16.5 Clase 125/150
- Presión máxima de trabajo: 2"-10": 16 Bar (250PSI)
- Temperatura de trabajo: -20°C/80°C

Butterfly valve wafer type stainless steel disc NBR soft seat

- Made of ductile Iron GGG-40 (GJS-400)
- Epoxy coating Epoxy RAL5013
- Stainless steel disc AISI-316
- NBR seat
- Design according to EN-12334, DIN 3202, EN 558-1
- Flanges according to UNE EN-1092-2 PN6-10-16 Ansi B16.5 Class 125/150
- Working pressure (Max): 2"-10": 16 Bar (250PSI)
- Working temperature: -20°C / 80°C

51142-050	2"
51142-065	2 1/2"
51142-080	3"
51142-100	4"
51142-125	5"
51142-150	6"
51142-200	8"
51142-250	10"

• Para automatización, consultar capítulo 3
See automation valves on chapter 3



FICHA TÉCNICA
TECHNICAL SHEET

51142MR

NEW



Válvula de mariposa tipo wafer disco inoxidable asiento blando NBR

- Fabricado en fundición Nodular GGG-40 (GJS-400)
- Recubrimiento en pintura Epoxy RAL5013
- Disco acero inoxidable AISI-316
- Asiento en NBR
- Diseño s/ EN-12334, DIN 3202, EN 558-1
- Bridas s/ UNE EN-1092-2 PN6-10-16 Ansi B16.5 Clase 125/150
- Presión máxima de trabajo: 2"-10": 16 Bar (250PSI)
- Temperatura de trabajo: -20°C/80°C

Butterfly valve wafer type stainless steel disc NBR soft seat

- Made of ductile Iron GGG-40 (GJS-400)
- Epoxy coating Epoxy RAL5013
- Stainless steel disc AISI-316
- NBR seat
- Design according to EN-12334, DIN 3202, EN 558-1
- Flanges according to UNE EN-1092-2 PN6-10-16 Ansi B16.5 Class 125/150
- Working pressure (Max): 2"-10": 16 Bar (250PSI)
- Working temperature: -20°C / 80°C

51142-050MR	2"
51142-065MR	2 1/2"
51142-080MR	3"
51142-100MR	4"
51142-125MR	5"
51142-150MR	6"
51142-200MR	8"
51142-250MR	10"
51142-300MR	12"



FICHA TÉCNICA
TECHNICAL SHEET

CÓDIGO CODE _____
MEDIDA SIZE _____

5140



Válvula de mariposa tipo wafer EPDM disco poliamida 11

- Fabricado en fundición nodular GGG-40 (GJS-400)
- Recubrimiento en pintura Epoxy RAL3020 (250µ)
- Disco fundición con recubrimiento en poliamida 11 (200µ)
- Asiento EPDM
- Bridas según UNE EN1092-2 PN6-10-16
- ANSI B16.5 Clase 125/150
- Working pressure (max): 16 Bar (PN-16)
- Working temperatura: -20°C / 120°C

Butterfly valve wafer type EPDM polyamide 11 disc

- Made of ductile iron GGG-40 (GJS-400)
- Epoxy coating RAL3020 (250µ)
- Disc on ductile iron with polyamide 11 coating (200µ)
- EPDM seat gasket
- Flanges according to UNE EN1092-2 PN6-10-16
- Working pressure (max): 16 Bar (PN-16)
- Working temperatura: -20°C / 120°C

5140-050	2"
5140-065	2 1/2"
5140-080	3"
5140-100	4"
5140-125	5"
5140-150	6"
5140-200	8"
5140-250	10"

• Para automatización, consultar capítulo 3
See automation valves on chapter 3



FICHA TÉCNICA
TECHNICAL SHEET

5141



Válvula de mariposa tipo wafer disco inoxidable asiento blando EPDM

- Fabricado en fundición nodular GGG-40 (GJS-400)
- Recubrimiento en pintura Epoxy RAL3020 (250µ)
- Disco acero inoxidable AISI-316
- Asiento EPDM
- Bridas según UNE EN1092-2 PN6-10-16 ANSI B16.5 Clase 125/150
- Presión máxima de trabajo: 16 Bar (PN-16)
- Temperatura de trabajo: -20°C / 120°C

Butterfly valve wafer type stainless steel disc EPDM soft seat

- Made of ductile iron GGG-40 (GJS-400)
- Epoxy coating RAL3020 (250µ)
- Stainless steel disc AISI-316
- Asiento EPDM
- Flanges according to UNE EN1092-2 PN6-10-16 ANSI B16.5 Class 125/150
- Working pressure (max): 16 Bar (PN-16)
- Working temperature: -20°C / 120°C

5141-040	1 1/2"
5141-050	2"
5141-065	2 1/2"
5141-080	3"
5141-100	4"
5141-125	5"
5141-150	6"
5141-200	8"
5141-250	10"

• Disponible hasta agotar existencias
While stocks lasts



FICHA TÉCNICA
TECHNICAL SHEET

51143



Válvula de mariposa tipo wafer disco y asiento PTFE

- Fabricado en fundición dúctil GGG-40 (GJS-400)
- Recubrimiento en pintura RAL5013 Epoxy
- Disco acero inoxidable 316 + PTFE
- Asiento PTFE
- Bridas s/ UNE EN1092-2 PN10-PN16 ANSI B16.5 Clase 125/150
- Presión máxima de trabajo: 16 Bar DN200 PN10
- Temperatura de trabajo: -20°C / 180°C

Butterfly valve wafer type PTFE disc and seat

- Made of ductile iron GGG-40 (GJS-400)
- Epoxy coating RAL5013
- Stainless steel disc 316 + PTFE
- PTFE seat gasket
- Flanges according to UNE EN1092-2 PN10 ANSI B16.1 Class 125/150 PN16
- Working pressure (Max): 16 Bar DN200 PN10
- Working temperature: -20°C / 180°C

51143-050	2"
51143-065	2 1/2"
51143-080	3"
51143-100	4"
51143-125	5"
51143-150MR*	6"
51143-200MR*	8"

* Reductor manual
* Gear operator

• Para automatización, consultar capítulo 3
See automation valves on chapter 3



FICHA TÉCNICA
TECHNICAL SHEET

CÓDIGO CODE _____
MEDIDA SIZE _____

51151



Válvula de mariposa tipo wafer disco inoxidable asiento rígido EPDM

ECO

- Fabricado en fundición gris DN50-DN150 GG25 y fundición dúctil >DN200 GGG-40
- Recubrimiento en pintura Epoxy RAL5013
- Disco acero inoxidable AISI-316
- Material asiento: EPDM
- Diseño s/ EN-12334, DIN 3202, EN 558-1
- Bridas PN-10/PN-16 Ansi B16.5 Clase 125/150
- Presión máxima de trabajo: 16 Bar (250 psi)
- Temperatura de trabajo: -20°C/120°C

Butterfly valve wafer type stainless steel disc EPDM hard seat

- Made of cast iron DN25-DN150 GG25 and ductil iron >DN200 GGG-40
- Epoxy coating epoxy RAL5013
- Stainless steel disc AISI-316
- Seat gasket material: EPDM
- Design according to EN-12334, DIN 3202, EN 558-1
- Flanges according to UNE EN-1092-2 PN-10/ PN-16 Ansi B16.5 Class 125/150
- Working pressure (max): 16 Bar (250 psi)
- Working temperature: -20°C/120°C

51151-040	1 1/2"
51151-050	2"
51151-065	2 1/2"
51151-080	3"
51151-100	4"
51151-125	5"
51151-150	6"
51151-200	8"
51151-250	10"

• Para automatización, consultar capítulo 3
See automation valves on chapter 3



FICHA TÉCNICA
TECHNICAL SHEET

51151MR



Válvula de mariposa tipo wafer disco inoxidable asiento rígido EPDM con reductor manual

ECO

- Fabricado en fundición DN50-DN150 GG-25 Fundición dúctil >DN200 GGG-40
- Recubrimiento en pintura Epoxy RAL5013
- Disco acero inoxidable AISI-316
- Asiento elastómero EPDM
- Diseño s/ EN-12334, DIN 3202, EN 558-1
- Bridas según UNE EN1092-2 PN-10/PN-16
- Presión máxima de trabajo: 2"-12": 16 Bar 14"-16": 10 Bar
- Temperatura de trabajo: -20°C / 120°C

Butterfly valve wafer type stainless steel disc EPDM hard seat with gear operator

- Made of cast iron DN50-DN150 GG-25 ductile iron >DN200 GGG-40
- Epoxy coating RAL5013
- Stainless steel disc AISI-316
- EPDM seat gasket
- Design according to EN-12334, DIN 3202, EN 558-1
- Flanges according to UNE EN1092-2 PN-10/ PN-16
- Working pressure (max): 2"-12": 16 Bar 14"-16": 10 Bar
- Working temperature: -20°C / 120°C

51151-050MR	2"
51151-065MR	2 1/2"
51151-080MR	3"
51151-100MR	4"
51151-125MR	5"
51151-150MR	6"
51151-200MR	8"
51151-250MR	10"
51151-300MR	12"
51151-350MR	14"
51151-400MR	16"



FICHA TÉCNICA
TECHNICAL SHEET

CÓDIGO CODE _____
MEDIDA SIZE _____

5115



Válvula de mariposa tipo wafer disco cromado asiento rígido EPDM

ECO

- Fabricado en fundición gris DN50-DN150 GG25 y fundición dúctil >DN200 GGG-40
- Recubrimiento en pintura epoxy RAL5013
- Disco cromado fundición dúctil EN-GJS-400
- Material asiento: EPDM
- Diseño s/ EN-12334, DIN 3202, EN 558-1
- Bridas s/ UNE EN-1092-2 PN10-PN16 Ansi B16.5 Clase 125/150
- Presión máxima de trabajo:
- 2"-12": 16 Bar (250PSI)
- Temperatura de trabajo: -20°C / 120°C

Butterfly valve wafer type chromed disc EPDM hard seat

- Made of cast iron DN25-DN150 GG25 and ductil iron >DN200 GGG-40
- Epoxy coating Epoxy RAL5013
- Chromed ductile iron EN-GJS-400
- Seat gasket material: EPDM
- Design according to EN-12334, DIN 3202, EN 558-1
- Flanges according to UNE EN-1092-2 PN10-PN16 Ansi B16.5 Class 125/150
- Working pressure (Max):
- 2"-12": 16 Bar (250PSI)
- Working temperature: -20°C / 120°C

5115-040	1 1/2"
5115-050	2"
5115-065	2 1/2"
5115-080	3"
5115-100	4"
5115-125	5"
5115-150	6"
5115-200	8"
5115-250	10"
5115-300*	12"

* Disponible hasta agotar existencias
* While stocks lasts

• Para automatización, consultar capítulo 3
See automation valves on chapter 3



FICHA TÉCNICA
TECHNICAL SHEET

5115MR



Válvula de mariposa tipo wafer disco cromado asiento rígido EPDM con reductor manual

ECO

- Fabricado en fundición gris DN50-DN150 GG-25 y fundición dúctil >DN200 GGG-40
- Recubrimiento en pintura epoxy RAL5013
- Disco cromado fundición dúctil EN-GJS-400
- Material asiento: EPDM
- Diseño s/ EN-12334, DIN 3202, EN 558-1
- Bridas s/ UNE EN-1092-2 PN10-PN16 Ansi B16.5 Clase 125/150
- Presión máxima de trabajo: 2"-12": 16 Bar (250PSI) 14"-24": 10 Bar (150PSI)
- Temperatura de trabajo: -20°C / 120°C

Butterfly valve wafer type chromed disc EPDM hard seat with gear operator

- Made of cast iron DN25-DN150 GG-25 and ductil iron >DN200 GGG-40
- Epoxy coating epoxy RAL5013
- Chromed ductile iron EN-GJS-400
- Seat gasket material: EPDM
- Design according to EN-12334, DIN 3202, EN 558-1
- Flanges according to UNE EN-1092-2 PN10-PN16 Ansi B16.5 Class 125/150
- Working pressure (Max): 2"-12": 16 Bar (250PSI) 14"-24": 10 Bar (150PSI)
- Working temperature: -20°C / 120°C

5115-050MR	2"
5115-065MR	2 1/2"
5115-080MR	3"
5115-100MR	4"
5115-125MR	5"
5115-150MR	6"
5115-200MR	8"
5115-250MR	10"
5115-300MR	12"
5115-350MR	14"
5115-400MR	16"
5115-500MR	20"
5115-600MR	24"



FICHA TÉCNICA
TECHNICAL SHEET

CÓDIGO CODE _____
MEDIDA SIZE _____

5144



Válvula de mariposa tipo lug disco inoxidable asiento blando NBR

- Fabricado en fundición dúctil GGG-40
- Recubrimiento en pintura Epoxy RAL5013
- Disco acero inoxidable AISI-316
- Asiento en elastómero NBR
- Fabricado bajo normativa: EN-1092-2 PN16
- Presión máxima de trabajo: 16 Bar
- Temperatura de trabajo: -20°C / 80°C

Butterfly valve lug type stainless steel disc NBR soft seat

- Made of ductile iron GGG-40
- Epoxy coating RAL5013
- Stainless steel disc AISI-316
- NBR seat gasket
- Manufactured according to standards: EN-1092-2 PN16
- Working pressure (Max): 16 Bar
- Working temperature: -20°C / 80°C

5144-050	2"
5144-065	2 1/2"
5144-080	3"
5144-100	4"
5144-125	5"
5144-150	6"
5144-200	8"

• Para automatización, consultar capítulo 3
See automation valves on chapter 3



FICHA TÉCNICA
TECHNICAL SHEET

5144MR



Válvula de mariposa tipo lug disco inoxidable asiento blando NBR con reductor manual

- Fabricado en fundición dúctil GGG-40
- Recubrimiento en pintura Epoxy RAL5013
- Disco acero inoxidable AISI-316
- Asiento en elastómero NBR
- Fabricado bajo normativa: EN-1092-2 PN16
- Presión máxima de trabajo: 16 Bar
- Temperatura de trabajo: -20°C / 80°C

Butterfly valve lug type stainless steel disc NBR soft seat, gear box

- Made of ductile iron GGG-40
- Epoxy coating RAL5013
- Stainless steel disc AISI-316
- NBR seat gasket
- Manufactured according to standards: EN-1092-2 PN16
- Working pressure (Max): 16 Bar
- Working temperature: -20°C / 80°C

5144-050MR	2"
5144-065MR	2 1/2"
5144-080MR	3"
5144-100MR	4"
5144-125MR	5"
5144-150MR	6"
5144-200MR	8"
5144-250MR	10"
5144-300MR	12"



FICHA TÉCNICA
TECHNICAL SHEET

CÓDIGO CODE _____
MEDIDA SIZE _____

51442

NEW



Válvula de mariposa tipo lug disco inoxidable asiento blando EPDM

- Fabricado en fundición dúctil GGG-40
- Recubrimiento en pintura Epoxy RAL5013
- Disco acero inoxidable AISI-316
- Asiento en elastómero EPDM
- Fabricado bajo normativa: EN-1092-2 PN16
- Presión máxima de trabajo: 16 Bar
- Temperatura de trabajo: -20°C / 80°C

Butterfly valve lug type stainless steel disc EPDM soft seat

- Made of ductile iron GGG-40
- Epoxy coating RAL5013
- Stainless steel disc AISI-316
- EPDM seat gasket
- Manufactured according to standards: EN-1092-2 PN16
- Working pressure (Max): 16 Bar
- Working temperature: -20°C / 80°C

51442-050	2"
51442-065	2 1/2"
51442-080	3"
51442-100	4"
51442-125	5"
51442-150	6"
51442-200	8"



FICHA TÉCNICA
TECHNICAL SHEET

51442MR

NEW



Válvula de mariposa tipo lug disco inoxidable asiento blando EPDM con reductor manual

- Fabricado en fundición dúctil GGG-40
- Recubrimiento en pintura Epoxy RAL5013
- Disco acero inoxidable AISI-316
- Asiento en elastómero EPDM
- Fabricado bajo normativa: EN-1092-2 PN16
- Presión máxima de trabajo: 16 Bar
- Temperatura de trabajo: -20°C / 80°C

Butterfly valve lug type stainless steel disc EPDM soft seat with gear box

- Made of ductile iron GGG-40
- Epoxy coating RAL5013
- Stainless steel disc AISI-316
- EPDM seat gasket
- Manufactured according to standards: EN-1092-2 PN16
- Working pressure (Max): 16 Bar
- Working temperature: -20°C / 80°C

51442-050MR	2"
51442-065MR	2 1/2"
51442-080MR	3"
51442-100MR	4"
51442-125MR	5"
51442-150MR	6"
51442-200MR	8"
51442-250MR	10"
51442-300MR	12"



FICHA TÉCNICA
TECHNICAL SHEET

- **Recambio** Reductor manual para válvulas de mariposa disponible en página 97
Spare part Hand wheel gear box for butterfly valves available page 97



VÁLVULAS DE RETENCIÓN NON RETURN VALVES

CÓDIGO CODE
MEDIDA SIZE

5116



Válvula de retención doble disco Inoxidable

- Fabricado en fundición Nodular GGG-40 (GJS-400)
- Recubrimiento en pintura Epoxy RAL5013 (250µ)
- Disco acero inoxidable AISI-304
- Asiento EPDM
- Bridas según UNE EN-1092-2 PN-10/PN-16 ANSI B16.5 Clase 125/150
- Presión máxima de trabajo: 16 Bar
- Temperatura de trabajo: -10°C / 80°C

Stainless Steel double disc check valve

- Made of ductile iron GGG-40 (GJS-400)
- Epoxy coating RAL5013 (250µ)
- Stainless steel disc AISI-304
- EPDM seat gasket
- Flanges according to UNE EN-1092-2 PN-10/PN-16
- ANSI B16.5 Class 125/150
- Working pressure (max): 16 Bar
- Working temperature: -10°C / 80°C

5116-040	1 1/2"
5116-050	2"
5116-065	2 1/2"
5116-080	3"
5116-100	4"
5116-125	5"
5116-150	6"
5116-200	8"
5116-250	10"
5116-300	12"
5116-350	14"



FICHA TÉCNICA
TECHNICAL SHEET

5125



Válvula de retención bola NBR con bridas

- Fabricado en fundición nodular GGG-40 (GJS-400)
- Recubrimiento en pintura Epoxy RAL5013 (250µ)
- Bola metálica con recubrimiento elastómero NBR
- Tornillería inoxidable AISI-304
- Diseño s/ EN-12334, DIN 3202, EN 558-1
- Bridas s/ UNE EN1092-2
- Presión máxima de trabajo: 16 Bar
- Temperatura de trabajo: 0°C / 80°C
- Presión mínima de apertura 0'05 Bar

Ball check valve, NBR ball, flanged end

- Made of nodular ductile Iron GGG-40 (GJS-400)
- Epoxy coating RAL5013 (250µ)
- Metal ball coated by NBR rubber
- Stainless steel bolts AISI-304
- Design according to EN-12334, DIN 3202, EN 558-1
- Flanges according to UNE EN1092-2
- Working pressure (Max): 16 Bar
- Working temperature (Max): 0° / 80°C
- Minimum opening pressure 0'05 Bar

5125-040	1 1/2"
5125-050	2"
5125-065	2 1/2"
5125-080	3"
5125-100	4"
5125-125	5"
5125-150	6"
5125-200	8"
5125-250	10"
5125-300	12"
5125-350	14"



FICHA TÉCNICA
TECHNICAL SHEET

5142



Válvula de retención bola NBR roscada

- Fabricado en fundición nodular EN-GJS-400
- Recubrimiento en pintura Epoxy RAL5013 (250µ)
- Bola de elastómero NBR
- Fabricado bajo normativa: UNE-EN-12334
- Roscas de conexión s/ norma ISO228
- Presión Máxima de trabajo: 10 Bar
- Temperatura de trabajo: 0°C / 80°C
- Presión mínima de apertura 0'01 Bar

Check valve threaded end NBR ball

- Made of ductile iron EN-GJS-400
- Epoxy coating RAL5013 (250µ)
- NBR rubber ball
- Manufactured according to standard UNE-EN-12334
- Connection threads according to standard ISO228
- Working pressure (Max): 10 Bar
- Working temperature: 0°C / 80°C
- Minimum opening pressure 0'01 Bar

5142-020	3/4"
5142-025	1"
5142-032	1 1/4"
5142-040	1 1/2"
5142-050	2"
5142-065	2 1/2"
5142-080	3"



FICHA TÉCNICA
TECHNICAL SHEET



VÁLVULAS DE COMPUERTA GATE VALVES

CÓDIGO CODE _____
MEDIDA SIZE _____

5113



Válvula de compuerta con bridas, eje fijo, cierre elástico EPDM

- Fabricado en fundición GGG-50 (GJS-500)
- Recubrimiento en pintura Epoxy RAL5013 (250µ)
- Asiento elástico fundición + recubrimiento EPDM
- Accionamiento mediante volante o cuadradillo
- Bridas S/UNE EN-1092-2 PN16
- Presión máxima de trabajo: 16 Bar (PN16)
- Temperatura de trabajo: -10°C / 120°C

EPDM resilient wedge gate valve, flanged ends

- Made of ductile iron GGG-50 (GJS-500)
- Epoxy coating RAL5013 (250µ)
- Ductile iron wedge coated by EPDM rubber
- Actuated by handwheel or square nut
- Flanges according to UNE EN-1092-2 PN16
- Working pressure (Max): 16 Bar (PN16)
- Working temperature: -10°C / 120°C

5113-040	1 1/2"
5113-050	2"
5113-065	2 1/2"
5113-080	3"
5113-100	4"
5113-125	5"
5113-150	6"
5113-200	8"
5113-250	10"
5113-300	12"
5113-350	14"
5113-400	16"
5113-500	20"
5113-600	24"

- Bridas PN-10 / PN-16 de 5113-040 hasta 5113-150.
Bridas PN-16 de 5113-200 hasta 5113-600
Flanges PN-10 / PN-16 from 5113-040 to 5113-150.
Flanges PN-16 from 5113-200 to 5113-600



FICHA TÉCNICA
TECHNICAL SHEET

5143



Válvula de compuerta cierre elástico EPDM extremos roscados

WRAS

- Fabricado en fundición GGG-50 (GJS-500)
- Recubrimiento en pintura Epoxy RAL5013 (250µ)
- Diseño según EN-12334
- Asiento elástico fundición con recubrimiento elastómero EPDM
- Accionamiento mediante volante o cuadradillo (30mm)
- Presión máxima de trabajo: 16 Bar (PN-16)
- Temperatura de trabajo: -10°C / 120°C

EPDM Resilient wedge gate valve, threaded ends

- Made of ductile iron GGG-50 (GJS-500)
- Epoxy coating RAL5013 (250µ)
- Design according to EN-12334
- Ductile iron wedge coated by EPDM rubber
- Actuated by handwheel or square nut (30mm)
- Working pressure (max): 16 Bar (PN-16)
- Working temperature: -10°C / 120°C

5143-020	3/4"
5143-025	1"
5143-032	1 1/4"
5143-040	1 1/2"
5143-050	2"



FICHA TÉCNICA
TECHNICAL SHEET



VÁLVULAS ESFERA BALL VALVES

CÓDIGO CODE _____
MEDIDA SIZE _____

5137



Válvula esfera dos piezas de hierro fundido con bridas

- Cuerpo fabricado en fundición gris (EN-GJL-250)
- Bola fabricada en acero inoxidable (AISI-201)
- Asientos de bola de PTFE
- Juntas en PTFE
- Bridas s/ UNE EN1092-2 PN16
- Cara a cara s/ UNE EN 558-1
- Presión máxima de trabajo: 16 Bar
- Temperatura de trabajo: -20°C / 120°C

Ball valve two pieces cast iron with flanges

- Body made of cast iron (EN-GJL-250)
- Stainless steel (AISI-201) ball
- Ball seats made of PTFE
- PTFE seat gaskets
- Flanges according to UNE EN1092-2 PN16
- Face to face according to UNE EN 558-1
- Working pressure (Max): 16 Bar
- Working temperature: -20°C / 120°C

5137-015	1/2"
5137-025	1"
5137-032	1 1/4"
5137-065	2 1/2"
5137-100	4"
5137-125	5"
5137-150	6"

- Disponible hasta agotar existencias
While stocks lasts



FICHA TÉCNICA
TECHNICAL SHEET

5145



Válvula esfera paso reducido una pieza

- Cuerpo fabricado en fundición gris (EN-GJL-250)
- Bola fabricada en acero inoxidable AISI-304
- Asientos de bola de PTFE reforzado
- Eje en acero inoxidable AISI-420
- Terminación a soldar según UNE-EN-12627
- Presión máxima de trabajo: DN25-50: 40 Bar
DN65-300MR*: 25 Bar
- Temperatura de trabajo: -30°C / 200°C

One piece reduced bore ball valve

- Body made of cast iron (EN-GJL-250)
- AISI-304 stainless steel ball
- Ball seats made of reinforced PTFE
- AISI-420 stainless steel stem
- Welding ends according to UNE-EN-12627
- Working pressure: DN25-50: 40 Bar
DN65-300MR*: 25 Bar
- Working temperature: -30°C / 200°C

5145-015	1/2"
5145-020	3/4"
5145-025	1"
5145-032	1 1/4"
5145-040	1 1/2"
5145-050	2"
5145-065	2 1/2"
5145-080	3"
5145-100	4"
5145-125	5"
5145-150	6"
5145-200	8"
5145-250MR*	10"
5145-300MR*	12"

- * Reductor manual
* Gear operator



FICHA TÉCNICA
TECHNICAL SHEET



VÁLVULAS DE GLOBO GLOBE VALVES

CÓDIGO CODE _____
MEDIDA SIZE _____

5130



Válvula de globo en acero al carbono con fuelle embreadada PN-40

- Fabricado en acero al carbono GS-C25
- Asiento en acero inoxidable 2Cr13 Stelite
- Fuelle INOX AISI-304 y juntas de grafito
- Fabricado bajo normativa: DIN 3356-82, EN-1092-2 PN40, DIN3202 F1
- Presión Máxima de trabajo: 40 Bar (PN40)
- Temperatura de trabajo: -10°C / 400°C

Cast steel bellow globe valve flanged ends PN-40

- Made of carbon steel casting GS-C25
- Stainless steel seat 2Cr13 Stelite
- Bellow in S.S. AISI-304 and graphite gaskets
- Manufactured according to standards: DIN 3356-82, En-1092-2 PN40, DIN3202 F1
- Working pressure (Max): 40 Bar (PN40)
- Working temperature: -10°C / 400°C

5130-015	1/2"
5130-020	3/4"
5130-025	1"
5130-032	1 1/4"
5130-040	1 1/2"
5130-050	2"
5130-065	2 1/2"
5130-080	3"
5130-100	4"
5130-125	5"
5130-150	6"
5130-200	8"



FICHA TÉCNICA
TECHNICAL SHEET

51302



Válvula de globo en acero al carbono con fuelle embreadada PN-16

- Fabricado en acero al carbono GS-C25
- Asiento en acero inoxidable 2Cr13 Stelite
- Fuelle INOX AISI-304 y juntas de grafito
- Fabricado bajo normativa: DIN 3356-82, EN-1092-2 PN16, DIN3202 F1
- Presión Máxima de trabajo: 16 Bar (PN16)
- Temperatura de trabajo: -10°C / 400°C

Cast steel bellow globe valve flanged ends PN-16

- Made of carbon steel casting GS-C25
- Stainless steel seat 2Cr13 Stelite
- Bellow in S.S. AISI-304 and graphite gaskets
- Manufactured according to standards: DIN 3356-82, En-1092-2 PN16, DIN3202 F1
- Working pressure (Max): 16 Bar (PN16)
- Working temperature: -10°C / 400°C

51302-015	1/2"
51302-020	3/4"
51302-025	1"
51302-032	1 1/4"
51302-040	1 1/2"
51302-050	2"
51302-065	2 1/2"
51302-080	3"
51302-100	4"
51302-125	5"
51302-150	6"
51302-200	8"
51302-250	10"



FICHA TÉCNICA
TECHNICAL SHEET

5131



Válvula de globo en fundición embreadada PN-16

- Fabricado en acero al carbono GG-25
- Recubrimiento en pintura Epoxy RAL5013 (250µ)
- Asiento en acero inoxidable AISI-304
- Juntas de grafito
- Fabricado bajo normativa: DIN 86251, DIN 2501, DIN3202 F1, EN-1092-2 PN16
- Presión máxima de trabajo: 16 Bar (PN16)
- Temperatura de trabajo: -20°C / 200°C

Cast steel bellow globe valve flanged ends PN-16

- Made of ductile iron GG-25
- Epoxy coating Epoxy RAL5013 (250µ)
- Stainless steel seat AISI-304
- Graphite gaskets
- Manufactured according to standards: DIN 86251, DIN 2501, DIN3202 F1, EN-1092-2 PN16
- Working pressure (Max): 16 Bar (PN16)
- Working temperature: -20°C / 200°C

5131-015	1/2"
5131-020	3/4"
5131-025	1"
5131-032	1 1/4"
5131-040	1 1/2"
5131-050	2"
5131-065	2 1/2"
5131-080	3"
5131-100	4"
5131-125	5"
5131-150	6"
5131-200	8"



FICHA TÉCNICA
TECHNICAL SHEET



FILTROS FILTERS

CÓDIGO CODE _____
MEDIDA SIZE _____

5110



Filtro en "Y" embreadado con tamiz 1,8mm

- Fabricado en fundición GG-25 (GJL-250)
- Recubrimiento en pintura Epoxy RAL5013 (250µ)
- Junta unión tapa EPDM
- Tamiz fabricado en acero inoxidable AISI 304
- Agujero tamiz 1,8mm (1.800 micras)
- Diseño s/ DIN 3202, EN 558-1
- Bridas s/ UNE EN1092-2
- Presión máxima de trabajo: 16 Bar (PN16)
- Temperatura de trabajo: -10°C / 100°C
- No apto para concentraciones de glicol >10%

Flanged 'Y' Strainer with sieve 1,8mm

- Made of ductile iron GG-25 (GJL-250)
- Epoxy coating RAL5013 (250µ)
- Cup joint EPDM
- Internal sieve made of stainless steel AISI 304
- Hole sieve size 1,8mm (1.800 microns)
- Design according to DIN 3202, EN 558-1
- Flanges according to UNE EN1092-2
- Working pressure (Max): 16 Bar (PN16)
- Working temperature: -10°C / 100°C
- Not suitable for glycol concentrations greater than 10%

5110-040	1 1/2"
5110-050	2"
5110-065	2 1/2"
5110-080	3"
5110-100	4"
5110-125	5"
5110-150	6"
5110-200	8"
5110-250	10"
5110-300	12"
5110-350	14"
5110-400	16"



FICHA TÉCNICA
TECHNICAL SHEET



MANGUITOS ELÁSTICOS EXPANSION JOINS

CÓDIGO CODE
MEDIDA SIZE

5120 EPDM 51202 NBR



Manguito elástico doble
onda extremos roscados

Double sphere rubber
expansion joint threaded
ends

- Tuercas de acero al carbono galvanizado
- Cuerpo de elastómero EPDM (Ref. 5120) o NBR (Ref.51202)
- Tejido interior de poliamida 6
- Roscas BSPT según norma ISO 228/1
- Presión nominal de trabajo: 16 Bar
- Presión de rotura: 30 Bar
- Temperatura de trabajo: -20°C / 120°C (Ref.5120) -20°C / 80°C (Ref.51202)
- Trabajo en vacío: 0.53 Bar

- Nuts made of galvanized carbon steel
- EPDM (Ref.5120) or NBR (Ref.51202) rubber body
- Polyamide 6 inner fabric
- BSPT threads under ISO228/1
- Working pressure: 16 Bar
- Bursting pressure: 30 Bar
- Working temperature: -20°C / 120°C (Ref.5120) -20°C / 80°C (Ref.51202)
- Vacuum pressure: 0.53 Bar

5120-020	51202-020	3/4"
5120-025	51202-025	1"
5120-032	51202-032	1 1/4"
5120-040	51202-040	1 1/2"
5120-050	51202-050	2"
5120-065	51202-065	2 1/2"



FICHA TÉCNICA
TECHNICAL SHEET

5121 EPDM 51212 NBR



Manguito elástico simple
onda con bridas

Single sphere rubber
expansion joint flanged ends

- Bridas de acero al carbono galvanizado
- Dimensiones bridas bajo norma: EN-1092 PN-10 PN-16 de DN32 hasta DN150 EN-1092 PN-16 de DN200 hasta DN400
- Cuerpo de elastómero EPDM (Ref. 5121) o NBR (Ref.51212)
- Tejido interior de poliamida 6
- Cable de acero circular
- Presión nominal de trabajo: 16 Bar
- 5121-0200 PN- 10
- Presión de rotura: 45 Bar
- Temperatura de trabajo: -20°C / 120°C (Ref.5121) -20°C / 80°C (Ref.51212)
- Trabajo en vacío: 0.56 Bar

- Flanges made of galvanized carbon steel
- Flange drills according to: EN-1092 PN-10 PN-16 from DN32 to DN150 EN-1092 PN-16 from DN200 to DN400
- EPDM (Ref.5121) or NBR (Ref.51212) rubber body
- Polyamide 6 inner fabric
- Circular hard steel wire
- Working pressure: 16 Bar
- 5121-0200 PN- 10
- Bursting pressure: 45 Bar
- Working temperature: -20°C / 120°C (Ref.5121) -20°C / 80°C (Ref.51212)
- Vacuum pressure: 0.56 Bar

5121-032*	51212-032*	1 1/4"
5121-040*	51212-040*	1 1/2"
5121-050*	51212-050*	2"
5121-065*	51212-065*	2 1/2"
5121-080*	51212-080*	3"
5121-100*	51212-100*	4"
5121-125*	51212-125*	5"
5121-150*	51212-150*	6"
5121-200***	51212-200***	8"
5121-0200**	51212-0200**	8"
5121-250***	51212-250***	10"
5121-300***	51212-300***	12"
5121-350***	51212-350***	14"
5121-400***	51212-400***	16"

- PN10/16 *
- PN10**
- PN16 ***



FICHA TÉCNICA
TECHNICAL SHEET

CÓDIGO CODE _____
MEDIDA SIZE _____

5129



Manguito elástico doble onda con bridas

Double sphere expansion joint flanged ends

- Bridas de acero al carbono galvanizado
- Dimensiones bridas bajo norma: EN-1092 PN-10 PN-16 de DN32 hasta DN150 EN-1092 PN-10 de DN200 hasta DN250
- Cuerpo de elastómero EPDM
- Tejido interior de poliamida
- Cable de acero circular
- Presión nominal de trabajo: 10 Bar
- Temperatura de trabajo: -20°C / 120°C
- Trabajo en vacío: 0.50 Bar
- Flanges made of galvanized carbon steel
- Flange drills according to: EN-1092 PN-10 PN-16 from DN32 to DN150 EN-1092 PN-10 from DN200 to DN250
- EPDM rubber body
- Polyamide inner fabric
- Circular hard steel wire
- Working pressure: 10 Bar
- Working temperature: -20°C / 120°C
- Vacuum pressure: 0.50 Bar

5129-050	2"
5129-065	2 1/2"
5129-080	3"
5129-100	4"
5129-125	5"
5129-150	6"
51290-200*	8"
51290-250*	10"

• PN10 *



FICHA TÉCNICA
TECHNICAL SHEET

- **Recambio** Pasador para manguitos elásticos simple onda disponibles en página 98
Spare part Control rod set elastic joints single sphere available page 98

2

ACCESORIOS
Y BRIDAS

FITTINGS AND FLANGES

Aplicaciones

Industria química, industrias petroquímicas y gas natural, industria alimentaria, entornos industriales de medios corrosivos y temperaturas extremas. Conducción de fluidos, calderas, condensadores, intercambio de calor, reactores, etc.

Applications

Chemical, petrochemical and natural gas, food processing, corrosive industrial environments and extreme temperatures. Fluid handling, boilers, condensers, heat exchangers, reactors, etc.

2.1

ACERO INOXIDABLE
STAINLESS STEEL

Rango de temperatura °C
Temperature range °C

 -20°
300°

**Producto**

Accesorio de acero
inoxidable

Normas de fabricación

Dimensiones según
Norma ISO 4144

Product

Stainless steel fitting

Manufacturing standards

Dimensions according
ISO 4144



SISTEMA MTPRESS
MTPRESS SYSTEM



FICHA TÉCNICA
TECHNICAL SHEET



01040

Curva 45° M-H

F-M 45° elbow

DVGW

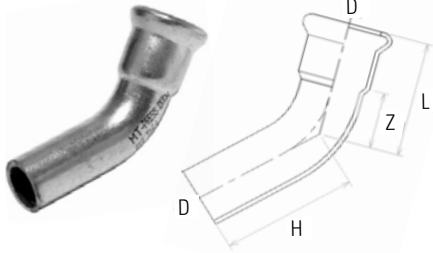

CÓDIGO CODE	MEDIDA SIZE	L	H	Z		
01040-015	15	32	43	12	160	10
01040-018	18	34	48	14	140	10
01040-022	22	38	52	18	90	10
01040-028	28	42	56	22	50	10
01040-035	35	52	62	28	50	5
01040-042	42	60	72	30	30	5
01040-054	54	72	84	37	20	5
01040-076	76	102	120	49	8	1
01040-088	88	115	134	55	4	1
01040-108	108	142	163	67	2	1

01041

Curva 45° H-H

F-F 45° elbow

DVGW

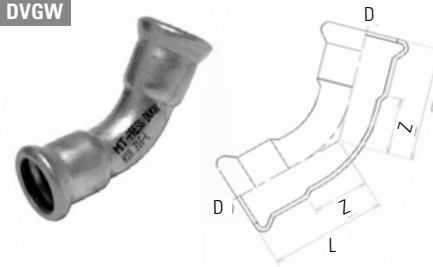

CÓDIGO CODE	MEDIDA SIZE	L	Z		
01041-015	15	32	12	160	10
01041-018	18	34	14	140	10
01041-022	22	38	18	100	10
01041-028	28	42	22	50	10
01041-035	35	52	28	60	5
01041-042	42	60	30	40	5
01041-054	54	72	37	20	5
01041-076	76	102	49	8	1
01041-088	88	115	55	4	1
01041-108	108	142	67	2	1

01001

Curva 90° M-H

M-F 45° elbow

DVGW

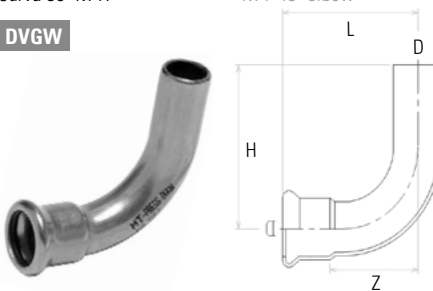

CÓDIGO CODE	MEDIDA SIZE	L	H	Z		
01001-015	15	43	49	23	140	10
01001-018	18	46	52	26	110	10
01001-022	22	53	57	32	70	10
01001-028	28	64	71	41	40	10
01001-035	35	78	90	52	50	5
01001-042	42	90	102	60	30	5
01001-054	54	110	122	75	15	5
01001-076	76	157	173	104	4	1
01001-088	88	178	199	118	3	1
01001-108	108	215	235	140	1	1

01002

Curva 90° H-H

F-F 45° elbow

DVGW

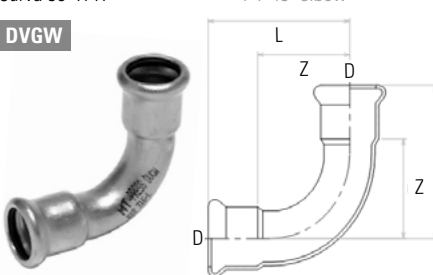

CÓDIGO CODE	MEDIDA SIZE	L	Z		
01002-015	15	43	23	140	10
01002-018	18	46	26	100	10
01002-022	22	53	32	80	10
01002-028	28	64	41	40	10
01002-035	35	78	52	50	5
01002-042	42	90	60	30	5
01002-054	54	110	75	15	5
01002-076	76	157	104	4	1
01002-088	88	178	118	3	1
01002-108	108	215	140	1	1

01003

Curva 90° M

DVGW



M 90° elbow

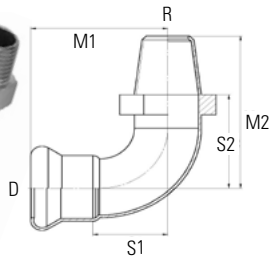

CÓDIGO CODE	MEDIDA SIZE	R	D	S1	S2	M1	M2		
01003-03525	35 x 1"	1"	35	61	63	87	89	15	1
01003-03532	35 x 1 1/4"	1 1/4"	35	61	63	87	89	10	1
01003-04232	42 x 1 1/4"	1 1/4"	42	83	85	113	115	6	1

01090

Curva 90° H

DVGW



F 90° elbow

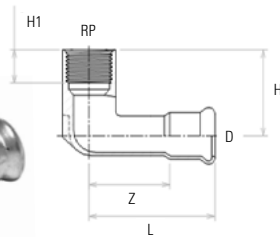

CÓDIGO CODE	MEDIDA SIZE	RP	H	H1	L	Z		
01090-01515	15 x 1/2"	1/2"	37	12	55	35	100	10
01090-01520	15 x 3/4"	3/4"	37	14	58	37	100	10
01090-01815	18 x 1/2"	1/2"	39	12	58	37	100	10
01090-01820	18 x 3/4"	3/4"	39	14	60	37	50	10
01090-02220	22 x 3/4"	3/4"	46	14	60	39	50	10
01090-02825	28 x 1"	1"	54	19	68	45	30	10
01090-03532	35 x 1 1/4"	1 1/4"	63	22	76	50	35	5

01092

Curva 90° M

DVGW



M 90° elbow

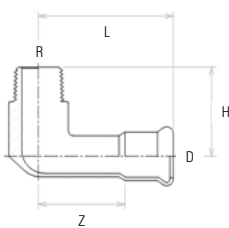

CÓDIGO CODE	MEDIDA SIZE	R	L	H	Z		
01092-01515	15 x 1/2"	1/2"	55	37	35	100	10
01092-01815	18 x 1/2"	1/2"	57	39	37	100	10
01092-01820	18 x 3/4"	3/4"	57	42	37	100	10
01092-02220	22 x 3/4"	3/4"	60	46	39	60	10
01092-02825	28 x 1"	1"	68	54	45	40	10
01092-03532	35 x 1 1/4"	1 1/4"	76	63	50	35	5
01092-04240	42 x 1 1/2"	1 1/2"	83	67	53	30	5
01092-05450	54 x 2"	2"	94	77	59	20	5

01131

Te hembra roscada

DVGW



Branch tee female outlet

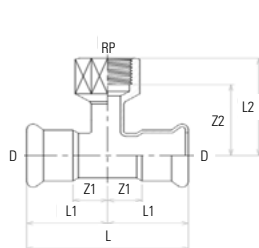

CÓDIGO CODE	MEDIDA SIZE	RP	L	L1	L2	Z1	Z2		
01131-01515	15 x 1/2" x 15	1/2"	66	33	38	13	24	100	10
01131-01815	18 x 1/2" x 18	1/2"	68	34	41	14	27	80	10
01131-01820	18 x 3/4" x 18	3/4"	68	34	43	14	28	70	10
01131-02215	22 x 1/2" x 22	1/2"	74	37	42	16	28	60	10
01131-02220	22 x 3/4" x 22	3/4"	74	37	45	16	30	60	10
01131-02815	28 x 1/2" x 28	1/2"	84	42	45	19	31	40	10
01131-02820	28 x 3/4" x 28	3/4"	84	42	47	19	32	30	10
01131-02825	28 x 1" x 28	1"	84	42	52	19	36	30	10
01131-03515	35 x 1/2" x 35	1/2"	100	50	49	24	34	40	5
01131-03520	35 x 3/4" x 35	3/4"	100	50	51	24	36	40	5
01131-03525	35 x 1" x 35	1"	100	50	56	24	40	40	5
01131-03532	35 x 1 1/4" x 35	1 1/4"	100	50	57	24	37	40	5
01131-04215	42 x 1/2" x 42	1/2"	114	57	53	27	39	30	5
01131-04220	42 x 3/4" x 42	3/4"	114	57	54	27	39	30	5
01131-04225	42 x 1" x 42	1"	114	57	59	27	43	30	5
01131-04240	42 x 1 1/2" x 42	1 1/2"	114	57	60	27	40	30	5
01131-05415	54 x 1/2" x 54	1/2"	138	69	58	34	44	15	5
01131-05420	54 x 3/4" x 54	3/4"	138	69	60	34	45	15	5
01131-05425	54 x 1" x 54	1"	138	69	65	34	49	15	5
01131-05450	54 x 2" x 54	2"	138	69	78	34	54	15	5
01131-07620	76 x 3/4" x 76	3/4"	230	115	70	62	55	6	1
01131-07650	76 x 2" x 76	2"	230	115	88	62	64	4	1
01131-08820	88 x 3/4" x 88	3/4"	260	130	78	70	62	2	1
01131-08850	88 x 2" x 88	2"	260	130	96	70	71	2	1
01131-10820	108 x 3/4" x 108	3/4"	310	155	86	80	71	2	1
01131-10850	108 x 2" x 108	2"	310	155	104	80	79	2	1

01130

Te igual

DVGW



Equal tee

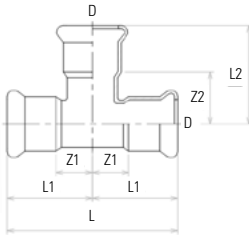

CÓDIGO CODE	MEDIDA SIZE	L	L1	L2	Z1	Z2		
01130-015	15	66	33	39	13	19	100	10
01130-018	18	68	34	40	14	20	80	10
01130-022	22	74	37	44	16	23	60	10
01130-028	28	84	42	52	19	29	30	10
01130-035	35	100	53	57	27	30	30	5
01130-042	42	114	57	65	27	34	20	5
01130-054	54	138	69	77	34	42	15	5
01130-076	76	230	115	110	62	58	4	1
01130-088	88	260	130	128	70	68	2	1
01130-108	108	310	150	153	78	81	1	1

01132

Te reducida

DVGW



Reducing tee

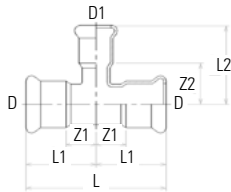

CÓDIGO CODE	MEDIDA SIZE	L	L1	L2	Z1	Z2		
01132-01815	18 x 15 x 18	68	34	40	14	20	80	10
01132-02215	22 x 15 x 22	74	37	43	16	22	70	10
01132-02218	22 x 18 x 22	74	37	43	16	22	60	10
01132-02228	22 x 28 x 22	74	37	49	16	24	60	10
01132-02815	28 x 15 x 28	84	42	45	19	25	40	10
01132-02818	28 x 18 x 28	84	42	46	19	25	40	10
01132-02822	28 x 22 x 28	84	42	47	19	26	40	10
01132-03515	35 x 15 x 35	100	50	49	24	29	40	5
01132-03518	35 x 18 x 35	100	50	50	24	29	40	5
01132-03522	35 x 22 x 35	100	50	51	24	30	40	5
01132-03528	35 x 28 x 35	100	50	56	24	33	40	5
01132-04215	42 x 15 x 42	114	57	53	27	33	30	5
01132-04218	42 x 18 x 42	114	57	53	27	33	30	5
01132-04222	42 x 22 x 42	114	57	55	27	34	30	5
01132-04228	42 x 28 x 42	114	57	60	27	37	30	5
01132-04235	42 x 35 x 42	114	57	61	27	34	25	5
01132-05415	54 x 15 x 54	138	69	59	34	39	15	5
01132-05418	54 x 18 x 54	138	69	59	34	39	15	5
01132-05422	54 x 22 x 54	138	69	61	34	40	15	5
01132-05428	54 x 28 x 54	138	69	66	34	43	15	5
01132-05435	54 x 35 x 54	138	69	67	34	40	15	5
01132-05442	54 x 42 x 54	138	69	71	34	38	15	5
01132-07622	76 x 22 x 76	230	115	71	62	50	8	1
01132-07628	76 x 28 x 76	230	115	76	62	53	6	1
01132-07635	76 x 35 x 76	230	115	77	62	50	6	1
01132-07642	76 x 42 x 76	230	115	81	62	48	6	1
01132-07654	76 x 54 x 76	230	115	87	62	53	6	1
01132-08822	88 x 22 x 88	260	130	76	70	58	2	1
01132-08828	88 x 28 x 88	260	130	83	70	61	2	1
01132-08835	88 x 35 x 88	260	130	87	70	58	2	1
01132-08842	88 x 42 x 88	260	130	87	70	58	2	1
01132-08854	88 x 54 x 88	260	130	94	70	63	2	1
01132-08876	88 x 76 x 88	260	130	118	70	69	2	1
01132-10822	108 x 22 x 108	310	152	87	77	73	2	1
01132-10828	108 x 28 x 108	310	155	93	80	76	2	1
01132-10835	108 x 35 x 108	310	155	93	80	69	2	1
01132-10842	108 x 42 x 108	310	155	97	80	67	2	1
01132-10854	108 x 54 x 108	310	155	103	80	71	2	1
01132-10876	108 x 76 x 108	310	155	127	80	77	2	1
01132-10888	108 x 88 x 108	310	155	137	80	80	1	1

01246

Reducción M-H

DVGW



M-F reducing

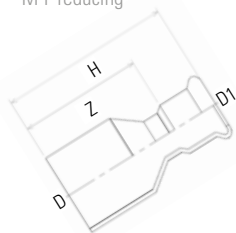

CÓDIGO CODE	MEDIDA SIZE	H	Z	📦	📦
01246-01815	18 x 15	62	42	160	10
01246-02215	22 x 15	62	42	150	10
01246-02218	22 x 18	61	40	130	10
01246-02815	28 x 15	65	43	120	10
01246-02818	28 x 18	67	47	120	10
01246-02822	28 x 22	66	45	100	10
01246-03515	35 x 15	75	55	150	5
01246-03518	35 x 18	78	58	150	5
01246-03522	35 x 22	68	47	150	5
01246-03528	35 x 28	76	53	120	5
01246-04215	42 x 15	84	60	100	5
01246-04218	42 x 18	80	60	80	5
01246-04222	42 x 22	84	63	80	5
01246-04228	42 x 28	77	59	80	5
01246-04235	42 x 35	81	54	80	5
01246-05415	54 x 15	96	76	50	5
01246-05418	54 x 18	92	72	50	5
01246-05422	54 x 22	96	75	50	5
01246-05428	54 x 28	98	75	50	5
01246-05435	54 x 35	96	70	50	5
01246-05442	54 x 42	102	72	40	5
01246-07642	76 x 42	142	112	24	1
01246-07654	76 x 54	145	110	24	1
01246-08854	88 x 54	147	112	12	1
01246-08876	88 x 76	161	108	8	1
01246-10854	108 x 54	162	127	7	1
01246-10876	108 x 76	176	123	7	1
01246-10888	108 x 88	203	143	4	1

01270

Manguito H-H

DVGW



F-F coupling

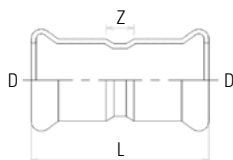

CÓDIGO CODE	MEDIDA SIZE	L	Z	📦	📦
01270-015	15	48	8	160	10
01270-018	18	48	8	140	10
01270-022	22	50	8	120	10
01270-028	28	54	8	80	10
01270-035	35	62	10	100	5
01270-042	42	71	11	60	5
01270-054	54	83	13	30	5
01270-076	76	141	35	8	1
01270-088	88	162	42	7	1
01270-108	108	194	44	3	1

01290

Tapón

DVGW



Cap

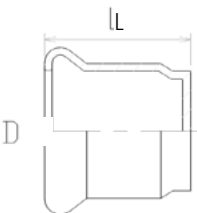

CÓDIGO CODE	MEDIDA SIZE	L	📦	📦
01290-015	15	34	200	10
01290-018	18	35	180	10
01290-022	22	39	150	10
01290-028	28	48	100	10
01290-035	35	51	120	5
01290-042	42	59	70	5
01290-054	54	67	50	5
01290-076	76	94	20	1
01290-088	88	103	16	1
01290-108	108	124	6	1

01340

Unión H

DVGW



F union

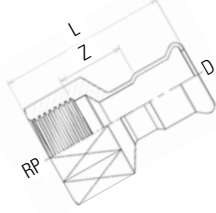

CÓDIGO CODE	MEDIDA SIZE (DxRp)	L	Z	📦	📦
01340-01510	15 x 3/8"	53	33	160	10
01340-01515	15 x 1/2"	55	20	160	10
01340-01520	15 x 3/4"	59	21	140	10
01340-01815	18 x 1/2"	60	24	120	10
01340-01820	18 x 3/4"	60	26	120	10
01340-02215	22 x 1/2"	58	24	100	10
01340-02220	22 x 3/4"	61	25	100	10
01340-02225	22 x 1"	66	26	100	10
01340-02820	28 x 3/4"	64	26	60	10
01340-02825	28 x 1"	70	28	60	10
01340-02832	28 x 1 1/4"	71	26	60	10
01340-03525	35 x 1"	66	20	80	5
01340-03532	35 x 1 1/4"	72	25	80	5
01340-03540	35 x 1 1/2"	72	25	60	5
01340-04232	42 x 1 1/4"	70	20	50	5
01340-04240	42 x 1 1/2"	76	21	40	5
01340-05440	54 x 1 1/2"	76	21	30	5
01340-05450	54 x 2"	94	34	30	5
01340-07665	76 x 2 1/2"	117	38	8	1

01341

Unión M

DVGW



M union

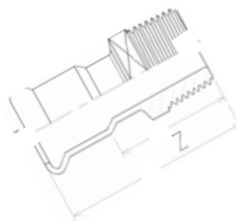

CÓDIGO CODE	MEDIDA SIZE (DxRp)	L	Z	📦	📦
01341-01510	15 x 3/8"	53	33	160	10
01341-01515	15 x 1/2"	54	35	160	10
01341-01520	15 x 3/4"	58	37	160	10
01341-01815	18 x 1/2"	55	35	120	10
01341-01820	18 x 3/4"	59	39	120	10
01341-02215	22 x 1/2"	56	35	100	10
01341-02220	22 x 3/4"	60	39	100	10
01341-02225	22 x 1"	63	42	80	10
01341-02820	28 x 3/4"	66	43	60	10
01341-02825	28 x 1"	68	45	60	10
01341-02832	28 x 1 1/4"	70	47	50	10
01341-03525	35 x 1"	69	43	100	5
01341-03532	35 x 1 1/4"	71	44	100	5
01341-03540	35 x 1 1/2"	71	44	100	5
01341-04232	42 x 1 1/4"	75	46	50	5
01341-04240	42 x 1 1/2"	75	46	50	5
01341-05440	54 x 1 1/2"	84	49	30	5
01341-05450	54 x 2"	90	55	30	5
01341-07665	76 x 2 1/2"	120	62	8	1
01341-08880	88 x 3"	133	70	7	1
01341-08100	108 x 4"	158	82	3	1

01359

Racor dos piezas H

DVGW



F tap connector two pieces

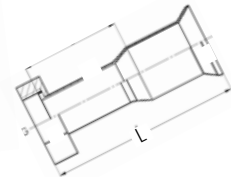

CÓDIGO CODE	MEDIDA SIZE (DxG)	L	Z	📦	📦
01359-01515	15 x 1/2"	50	18	200	10
01359-01520	15 x 3/4"	49	18	180	10
01359-01815	18 x 1/2"	51	20	180	10
01359-01820	18 x 3/4"	51	20	160	10
01359-02220	22 x 3/4"	52	21	120	10
01359-02225	22 x 1"	54	21	120	10
01359-02825	28 x 1"	59	24	80	10
01359-02832	28 x 1 1/4"	61	26	60	10
01359-03532	35 x 1 1/4"	63	25	80	5
01359-03540	35 x 1 1/2"	63	25	80	5
01359-04240	42 x 1 1/2"	68	25	70	5
01359-04250	42 x 2"	68	25	60	5
01359-05450	54 x 2"	74	24	30	5
01359-05465	54 x 2 1/2"	75	24	30	5

- Junta plana incluida
Flat joint included

01321

Brida adaptador

Adaptor flange

DVGW

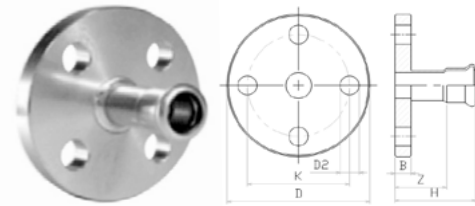

CÓDIGO CODE	MEDIDA SIZE	D	K	B	H	Z	D2	N		
01321-015	15	95	65	11	43	23	14	4	20	1
01321-018	18	95	65	11	44	23	14	4	20	1
01321-022	22	105	75	12	48	26	14	4	12	1
01321-028	28	115	85	14	55	31	14	4	12	1
01321-035	35	140	100	15	63	34	18	4	10	1
01321-042	42	150	110	16	72	40	18	4	8	1
01321-054	54	165	125	18	84	49	18	4	6	1
01321-076	76	185	145	18	133	76	18	4	3	1
01321-088	88	200	160	20	149	88	18	8	3	1
01321-108	108	220	180	20	174	98	18	8	2	1

01360

Racor tres piezas

Tap connector three pieces

DVGW

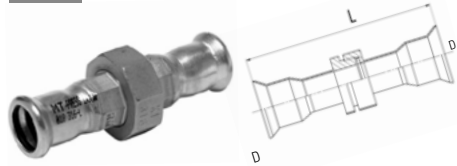

CÓDIGO CODE	MEDIDA SIZE (D)	L		
01360-015	15	89	100	10
01360-018	18	92	80	10
01360-022	22	99	50	10
01360-028	28	112	30	10
01360-035	35	119	40	5
01360-042	42	128	30	5
01360-054	54	141	15	5

01440

Conector H

F connector

DVGW

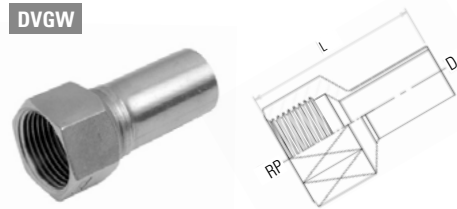

CÓDIGO CODE	MEDIDA SIZE (DXRp)	L		
01440-01515	15 x 1/2"	55	180	10
01440-01815	18 x 1/2"	60	160	10
01440-01820	18 x 3/4"	62	140	10
01440-02215	22 x 1/2"	59	100	10
01440-02220	22 x 3/4"	62	100	10
01440-02820	28 x 3/4"	64	60	10
01440-02825	28 x 1"	70	60	10

01441

Conector M

M connector

DVGW

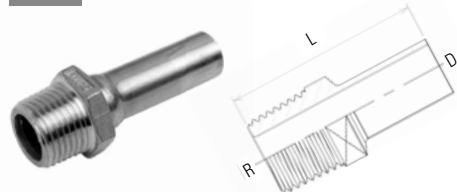

CÓDIGO CODE	MEDIDA SIZE (DXR)	L		
01441-01515	15 x 1/2"	53	180	10
01441-01815	18 x 1/2"	57	160	10
01441-01820	18 x 3/4"	61	140	10
01441-02215	22 x 1/2"	57	100	10
01441-02220	22 x 3/4"	61	100	10
01441-02820	28 x 3/4"	65	60	10
01441-02825	28 x 1"	68	60	10

01472

Codo placa

Wall plated elbow

DVGW

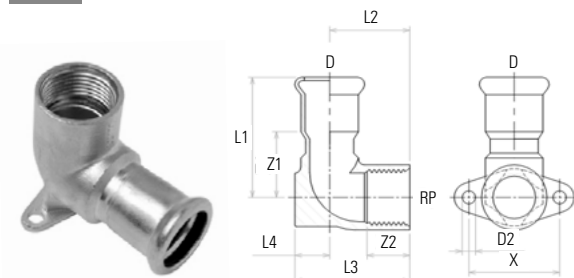

CÓDIGO CODE	MEDIDA SIZE (DXRp)	L1	L2	L3	L4	Z1	Z2	D2	X		
01472-01515	15 x 1/2"	50	30	43	13	30	15	5	34	100	10
01472-01815	18 x 1/2"	51	30	43	13	30	15	5	34	90	10
01472-02220	22 x 3/4"	55	34	51	17	34	16	6	40	60	10

COMPATIBILIDAD DIÁMETRO / MATERIALES DIAMETER / MATERIAL COMPATIBILITY

FLUIDOS FLUIDS	EPDM	FKM
ACEITES SINTÉTICOS SYNTHETIC OIL	x	✓
ACEITES VEGETALES VEGETABLE OIL	✓	✓
ÁCIDO ACÉTICO ACETIC ACID	✓	x
ÁCIDO CLORHÍDRICO HYDROCHLORIC ACID	✓	✓
ÁCIDO FÓRMICO FORMIC ACID	✓	x
ÁCIDO NÍTRICO NITRIC ACID	x	✓
ÁCIDO SULFÚRICO SULFURIC ACID	x	✓
AMONÍACO AMMONIA	✓	x
AGUA DESTILADA DISTILLED WATER	✓	✓
AGUA LÍQUIDA <100° LIQUID WATER	✓	✓
AGUA VAPOR <140° STEAM	✓	✓
AGUA VAPOR >140° STEAM	x	✓
AIRE COMPRIMIDO COMPRESSED AIR	x	✓
ARGÓN ARGON	✓	✓
DIÓXIDO DE CARBONO CARBON DIOXIDE	✓	✓
ETILENGLICOL ETILENGLICOL	✓	✓
PROPILENGLICOL PROPYLENGLICOL	✓	✓
NITRÓGENO NITROGEN	✓	✓
BENZENO BENZENE	x	✓
GASOLINA GASOLINE	x	✓
GASOIL / DIESEL / FUELOIL DIESEL	x	✓
HIDRÓXIDO SÓDICO SODIUM HYDROXIDE	✓	✓
METANOL METANOL	✓	✓
TETRACLOROETILENO TETRACHLORETHYLENE	x	✓
XILENO XYLENE	x	✓

- x Incompatible Non suitable
- ✓ Compatible Suitable

APLICACIONES APPLICATIONS

APLICACIÓN APPLICATION	TUBERÍA PIPE	JUNTA GASKET	PRESIÓN MÁX. (BAR) MAX. PRESSURE (BAR)	T (°C)
Agua potable Drinkable water	AISI-316L	EPDM	16 bar	0/+120°C
Calefacción Heating systems	AISI-304/AISI-316L	EPDM	16 bar	0/+120°C
Sistemas antiincendios Firefighting systems	AISI-304/AISI-316L	EPDM	12,5 bar	Ambiente Room temp.
Refrigeración Air cooling	AISI-304/AISI-316L	EPDM	16 bar	-20/+120°C
Solar Solar power	AISI-304/AISI-316L	FKM	6 bar	-20/+180°C
Aire Comprimido Compressed air	AISI-304/AISI-316L	EPDM/ FKM	16 bar (DN15-DN54)	Ambiente Room temp.
Nitrógeno Nitrogen (gas)	AISI-316L	EPDM	16 bar (DN15-DN54) 10 bar (DN76-DN108)	Ambiente Room temp.
Argón Argon (gas)	AISI-316L	EPDM	16 bar (DN15-DN54) 10 bar (DN76-DN108)	Ambiente Room temp.
Dióxido Carbono Carbon dioxide (gas)	AISI-304/AISI-316L	EPDM	16 bar (DN15-DN54) 10 bar (DN76-DN108)	Ambiente Room temp.
Vapor Steam	AISI-316L	FKM	1 bar	Max. +120°C
Vacío Vacuum	AISI-304/AISI-316L	EPDM	-0,8 bar	Ambiente Room temp.

- Las aplicaciones y los valores descritos en esta tabla son orientativos y basadas en las instalaciones ya realizadas y supervisadas por MT Valves and Fittings y que están funcionando correctamente.
The applications and values described in this table are indicative and based on the installations already carried out and supervised by MT Valves and Fittings and that are functioning correctly.

• **Recambios** Junta EPDM/FKM disponibles en página 98
Spare parts O-ring EPDM/FKM available page 98

015004**AISI 304**Tubo soldado en acero
inoxidable 304Welded Stainless steel
pipe 304**DVGW**

CÓDIGO CODE	MEDIDA SIZE	METROS METERS
015004-01506	15 x 0.6	5
015004-01510	15 x 1.0	6
015004-01807	18 x 0.7	5
015004-01810	18 x 1.0	6
015004-02207	22 x 0.7	5
015004-02212	22 x 1.2	6
015004-02808	28 x 0.8	5
015004-02812	28 x 1.2	6
015004-03510	35 x 1.0	5
015004-03515	35 x 1.5	6
015004-04212	42 x 1.2	5
015004-04215	42 x 1.5	6
015004-05412	54 x 1.2	5
015004-05415	54 x 1.5	6
015004-07615	76.1 x 1.5	6
015004-07620	76.1 x 2.0	6
015004-08820	88.9 x 2.0	6
015004-10820	108 x 2.0	6

- Otras dimensiones bajo consulta
Other dimensions under request

015006**AISI 316L**Tubo soldado en acero
inoxidable 316LWelded Stainless steel
pipe 316L**DVGW**

CÓDIGO CODE	MEDIDA SIZE	METROS METERS
015006-01506	15 x 0.6	5
015006-01510	15 x 1.0	6
015006-01807	18 x 0.7	5
015006-01810	18 x 1.0	6
015006-02207	22 x 0.7	5
015006-02212	22 x 1.2	6
015006-02808	28 x 0.8	5
015006-02812	28 x 1.2	6
015006-03510	35 x 1.0	5
015006-03515	35 x 1.5	6
015006-04212	42 x 1.2	5
015006-04215	42 x 1.5	6
015006-05412	54 x 1.2	5
015006-05415	54 x 1.5	6
015006-07615	76 x 1.5	6
015006-07620	76.1 x 2.0	6
015006-08820	88.9 x 2.0	6
015006-10820	108 x 2.0	6

- Otras dimensiones bajo consulta
Other dimensions under request

DIÁMETRO EXTERIOR EXTERNAL DIAMETER	GROSOR THICKNESS		PESO POR METRO (KG) WEIGHT PER METER (KG)	
	Serie 1	Serie 2	Serie 1	Serie 2
15	0,6	1	0,22	0,35
18	0,7	1	0,3	0,43
22	0,7	1,2	0,37	0,63
28	0,8	1,2	0,55	0,81
35	1	1,5	0,85	1,26
42	1,2	1,5	1,23	1,52
54	1,2	1,5	1,59	1,97
76,1	1,5	2	2,81	3,72
88,9	2	2	4,36	4,36
108	2	2	5,31	5,31

- Tubería de acero inoxidable según las norma DVGW GW 541 y UNE-EN-10088
Stainless steel pipe according to DVGW GW 541 and UNE-EN-10088

UAP432CFM

Máquina de prensar electro hidráulica con bluetooth y pantalla oled

Electrohydraulic machine for press with bluetooth and oled screen



CÓDIGO CODE

UAP432CFM

- Se suministra con: maletín, máquina, cargador (LGL1), una batería (18V/3) y un adaptador enchufable (NG2230)
Supplied with: briefcase, machine, charger (LGL1), a battery (18V/3) and a plug-in adapter (NG2230)
- Admite mordazas desde 15 a 108
Accepts jaws from 15 to 108.

SBM

Mordaza de prensar

Pressing jaw



CÓDIGO CODE

SB15M

MEDIDA SIZE

15

SB18M

18

SB22M

22

SB28M

28

SB35M

35

- Perfil M
M profile

SSKMN

Cadena de prensado

Pressing chain



CÓDIGO CODE

SSK42MN

MEDIDA SIZE

42

SSK54MN

54

- Perfil M
M profile

SBK4254

Mordaza adaptadora

Adapter jaw



CÓDIGO CODE

SBK4254

MEDIDA SIZE

42-54

BPLP

Cadena de prensado

Pressing chain



CÓDIGO CODE

BP761LP

MEDIDA SIZE

76,1

BP889LP

88,9

BP108LP

108

- Baja presión 48Bar
Low pressure 48Bar

SBKUAP4

Mordaza adaptadora

Adapter jaw



CÓDIGO CODE

SBKUAP4

MEDIDA SIZE

76-88-108

PACK MAP 2L19

Klauke
A Textron Company

Maletín pack maquinaria press MAP2L19

Briefcase machine press pack MAP2L19



CÓDIGO CODE

PACKMAP2L19

MEDIDA SIZE

15-35 (M)

- Se suministra con: maletín, máquina, cargador, una batería y mordazas 15-18-22-28-35.
Supplied with: case, machine, charger, battery and clamps 15-18-22-28-35.



ABARCONES U-BOLTS



FICHA TÉCNICA
TECHNICAL SHEET



160101

Abarcón acero al carbono
no cincado

U-bolt carbon steel
galvanized



CÓDIGO CODE	MEDIDA SIZE	📦	📦
160101-008	1/4"	600	1
160101-010	3/8"	600	1
160101-015	1/2"	600	1
160101-020	3/4"	600	1
160101-025	1"	600	1
160101-032	1 1/4"	600	1
160101-040	1 1/2"	300	1
160101-050	2"	200	1
160101-065	2 1/2"	150	1
160101-080	3"	125	1
160101-090	3 1/2"	125	1
160101-100	4"	100	1
160101-125	5"	125	1
160101-150	6"	50	1
160101-200	8"	50	1

160204 AISI 304 (A2)

Abarcón acero inoxidable

U-bolt stainless steel



CÓDIGO CODE	MEDIDA SIZE	📦	📦
160204-008	1/4"	100	1
160204-010	3/8"	100	1
160204-015	1/2"	100	1
160204-020	3/4"	100	1
160204-025	1"	100	1
160204-032	1 1/4"	100	1
160204-040	1 1/2"	100	1
160204-050	2"	100	1
160204-065	2 1/2"	50	1
160204-080	3"	50	1
160204-090	3 1/2"	50	1
160204-100	4"	50	1
160204-125	5"	50	1
160204-150	6"	25	1
160204-200	8"	25	1

160306 AISI 316 (A4)

Abarcón acero inoxidable

U-bolt stainless steel



CÓDIGO CODE	MEDIDA SIZE	📦	📦
160306-008	1/4"	100	1
160306-010	3/8"	100	1
160306-015	1/2"	100	1
160306-020	3/4"	100	1
160306-025	1"	100	1
160306-032	1 1/4"	100	1
160306-040	1 1/2"	100	1
160306-050	2"	100	1
160306-065	2 1/2"	50	1
160306-080	3"	50	1
160306-090	3 1/2"	50	1
160306-100	4"	50	1
160306-125	5"	50	1
160306-150	6"	25	1
160306-200	8"	25	1

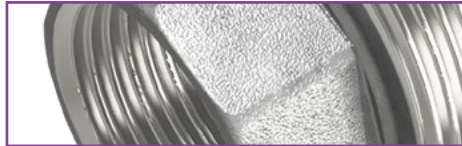

**ROSCADOS
THREADED**



FICHA TÉCNICA
TECHNICAL SHEET



8090

Codo 90° H-H

F-F elbow 90°

EAN CODE

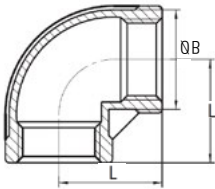

CÓDIGO CODE	MEDIDA SIZE	L	B	📦	📦
8090-008	1/4"	19	16,5	400	10
8090-010	3/8"	23	20	300	10
8090-015	1/2"	27	24,5	150	10
8090-020	3/4"	32	30	100	10
8090-025	1"	38	37,5	60	5
8090-032	1 1/4"	45	46,5	30	5
8090-040	1 1/2"	48	53	25	5
8090-050	2"	57	65,5	10	1
8090-065	2 1/2"	69	82	6	1
8090-080	3"	78	95,5	4	1
8090-100	4"	96	121,5	2	1

80902

Codo 90° H-H reducido

F-F reducing Elbow 90°

EAN CODE

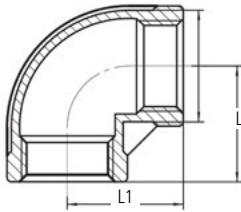

CÓDIGO CODE	MEDIDA SIZE	L	L1	📦	📦
80902-02015	3/4" x 1/2"	29	30	100	10

8092

Codo 90° M-H

M-F elbow 90°

EAN CODE

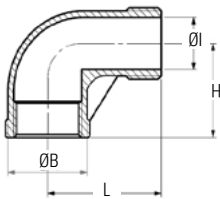

CÓDIGO CODE	MEDIDA SIZE	B	H	L	I	📦	📦
8092-006	1/8"	13	17	26	5,5	500	10
8092-008	1/4"	16,5	19	27	8	400	10
8092-010	3/8"	19,7	23	29	11,5	350	10
8092-015	1/2"	24,5	27	35	15	150	10
8092-020	3/4"	30	32	40	20,5	100	10
8092-025	1"	37,5	38	46	26	60	5
8092-032	1 1/4"	46,5	45	54	34,5	30	5
8092-040	1 1/2"	53	48	57	40	25	5
8092-050	2"	65,5	57	70	51	10	5
8092-065	2 1/2"	82	69	83	65,5	6	1
8092-080	3"	95,5	78	94	77,5	4	1
8092-100	4"	121,5	97	115	101,5	2	1

8120

Codo 45° H-H

F-F elbow 45°

EAN CODE

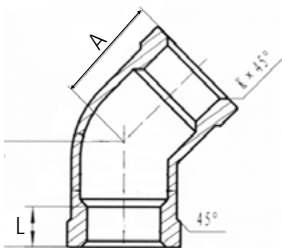

CÓDIGO CODE	MEDIDA SIZE	A	L	K	📦	📦
8120-008	1/4"	17	11	1	500	10
8120-010	3/8"	19	12,5	1	250	10
8120-015	1/2"	21	11	1,5	150	10
8120-020	3/4"	25	12	1,5	100	10
8120-025	1"	29	14	2	60	5
8120-032	1 1/4"	33	16	2	30	5
8120-040	1 1/2"	37	17	2	30	5
8120-050	2"	42	20	2	15	5

8130

Te 90° H

EAN CODE



F tee 90°

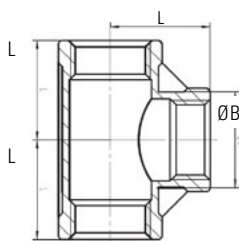

CÓDIGO CODE	MEDIDA SIZE	B	L		
8130-008	1/4"	16,5	19	400	10
8130-010	3/8"	20	23	200	10
8130-015	1/2"	24,5	27	100	10
8130-020	3/4"	30	32	60	10
8130-025	1"	37,5	38	40	5
8130-032	1 1/4"	46,5	45	20	5
8130-040	1 1/2"	53	48	15	5
8130-050	2"	65,5	57	10	1
8130-065	2 1/2"	82	69	4	1
8130-080	3"	95,5	78	2	1
8130-100	4"	121,5	96	1	1

8132

Te reducida H

EAN CODE



F reduced tee

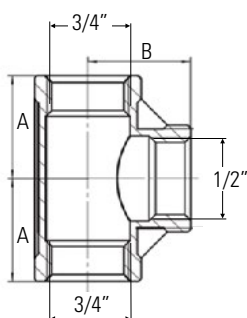

CÓDIGO CODE	MEDIDA SIZE	A	B		
8132-02015	3/4" x 1/2"	29	30	60	10

8149

Entronque R-S de tubo

EAN CODE



M weld nipple from pipe

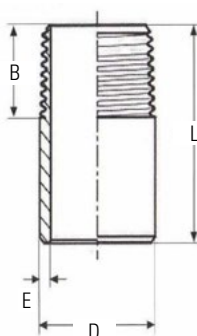

CÓDIGO CODE	MEDIDA SIZE	L	B	D	E		
8149-008	1/4"	30	13	13,6	2	1000	10
8149-010	3/8"	30	13	17,2	2	600	10
8149-015	1/2"	35	16	21,3	2,6	450	10
8149-020	3/4"	40	16	26,9	2,6	240	10
8149-025	1"	40	19	33,7	3	140	5
8149-032	1 1/4"	50	21	42,4	3	70	5
8149-040	1 1/2"	50	22	48,3	4	60	5
8149-050	2"	50	26	60,3	3,9	36	1
8149-065	2 1/2"	60	30	76,1	4,6	18	1
8149-080	3"	70	34	88,9	5,4	12	1
8149-100	4"	80	39	114,3	5,7	6	1

8150

Entronque roscar M-M de tubo

EAN CODE



M-M pipe nipple from pipe

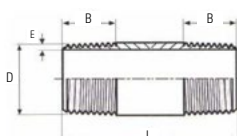

CÓDIGO CODE	MEDIDA SIZE	L	B	D	E		
8150-008	1/4"	39	10	13,5	2	1000	10
8150-010	3/8"	41,3	11	17,1	2,2	400	10
8150-015	1/2"	55	14	21,3	2,9	260	10
8150-020	3/4"	60	17	26,9	2,9	160	10
8150-025	1"	60	18	32,6	3,2	100	5
8150-032	1 1/4"	75	21	42,4	3,2	40	5
8150-040	1 1/2"	75	24	47	3,2	40	5
8150-050	2"	90	26	58	3,6	24	5

8180

Cruz

EAN CODE



Cross

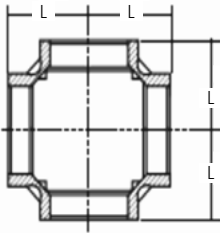

CÓDIGO CODE	MEDIDA SIZE	L	📦	📦
8180-008	1/4"	19	200	10
8180-010	3/8"	23	150	10
8180-015	1/2"	27	80	10
8180-020	3/4"	32	60	10
8180-025	1"	38	25	5
8180-032	1 1/4"	45	20	5
8180-040	1 1/2"	48	10	5
8180-050	2"	57	4	1
8180-065	2 1/2"	69	3	1
8180-080	3"	78	2	1
8180-100	4"	96	1	1

8240

Manguito reducción H-H

EAN CODE



F-F reduced Socket

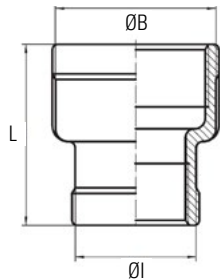

CÓDIGO CODE	MEDIDA SIZE	L	B	I	📦	📦
8240-00806	1/4" x 1/8"	25	16,5	13	600	10
8240-01006	3/8" x 1/8"	26	20	13	500	10
8240-01008	3/8" x 1/4"	26	20	16,5	500	10
8240-01506	1/2" x 1/8"	34	24,5	13	350	10
8240-01508	1/2" x 1/4"	34	24,5	16,5	350	10
8240-01510	1/2" x 3/8"	34	24,5	20	350	10
8240-02008	3/4" x 1/4"	36	30	16,5	300	10
8240-02010	3/4" x 3/8"	36	30	20	300	10
8240-02015	3/4" x 1/2"	36	30	24,5	200	10
8240-02508	1" x 1/4"	42	38	17	200	5
8240-02510	1" x 3/8"	42	38	20,5	200	5
8240-02515	1" x 1/2"	42	37,5	24,5	200	5
8240-02520	1" x 3/4"	42	37,5	30	130	5
8240-03215	1 1/4" x 1/2"	48	49	26	100	5
8240-03220	1 1/4" x 3/4"	48	46,5	30	100	5
8240-03225	1 1/4" x 1"	48	46,5	37,5	100	5
8240-04008	1 1/2" x 1/4"	52	53,5	17	60	5
8240-04010	1 1/2" x 3/8"	52	54,5	25,5	60	5
8240-04015	1 1/2" x 1/2"	52	59	26	60	5
8240-04020	1 1/2" x 3/4"	52	53	30	60	5
8240-04025	1 1/2" x 1"	52	53	37,5	60	5
8240-04032	1 1/2" x 1 1/4"	52	53	46,5	50	5
8240-05025	2" x 1"	58	68,3	39	40	1
8240-05032	2" x 1 1/4"	58	65,5	46,5	40	1
8240-05040	2" x 1 1/2"	58	65,5	53	40	1
8240-06525	2 1/2" x 1"	65	82	48	24	1
8240-06532	2 1/2" x 1 1/4"	65	84,5	48	24	1
8240-06540	2 1/2" x 1 1/2"	65	81,5	53	24	1
8240-06550	2 1/2" x 2"	65	81,5	65,5	24	1

8270

Manguito H-H de tubo

EAN CODE



F-F socket from pipe

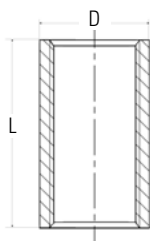

CÓDIGO CODE	MEDIDA SIZE	L	D	📦	📦
8270-008	1/4"	25	18,5	600	10
8270-010	3/8"	26	21,3	450	10
8270-015	1/2"	34	26,6	240	10
8270-020	3/4"	36	31,8	200	10
8270-025	1"	43	39,5	100	5
8270-032	1 1/4"	48	48,3	60	5
8270-040	1 1/2"	48	54,5	45	5
8270-050	2"	56	66,2	27	1
8270-065	2 1/2"	65	82	12	1
8270-080	3"	71	95	12	1
8270-100	4"	83	121,4	4	1

8241

Tuerca reducción M-H

EAN CODE

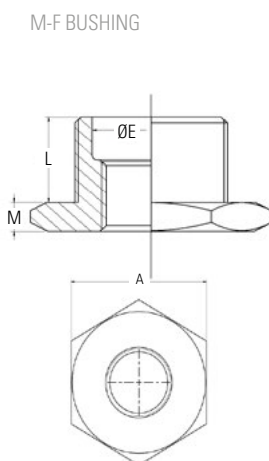

CÓDIGO CODE	MEDIDA SIZE	A	E	L	M		
8241-00806	1/4" x 1/8"	14,5	8	10,5	4	1000	10
8241-01006	3/8" x 1/8"	18,5	11,5	11	5	900	10
8241-01008	3/8" x 1/4"	18,5	11,5	11	5	900	10
8241-01506	1/2" x 1/8"	22,5	15	14,5	5	500	10
8241-01508	1/2" x 1/4"	22,5	15	14,5	5	500	10
8241-01510	1/2" x 3/8"	22,5	15	14,5	5	500	10
8241-02008	3/4" x 1/4"	28	20,5	15,5	5,5	350	10
8241-02010	3/4" x 3/8"	28	20,5	15,5	5,5	350	10
8241-02015	3/4" x 1/2"	28	20,5	15,5	5,5	350	10
8241-02508	1" x 1/4"	35	26	18	6	220	5
8241-02510	1" x 3/8"	35	26	18	6	220	5
8241-02515	1" x 1/2"	35	26	18	6	220	5
8241-02520	1" x 3/4"	35	26	18	6	220	5
8241-03215	1 1/4" x 1/2"	44	34,5	20,5	6,5	120	5
8241-03220	1 1/4" x 3/4"	44	34,5	20,5	6,5	120	5
8241-03225	1 1/4" x 1"	44	34,5	20,5	6,5	120	5
8241-04010	1 1/2" x 3/8"	49,5	20,5	20,5	6,5	90	5
8241-04015	1 1/2" x 1/2"	49,5	40	20,5	6,5	90	5
8241-04020	1 1/2" x 3/4"	49,5	40	20,5	6,5	90	5
8241-04025	1 1/2" x 1"	49,5	40	20,5	6,5	90	5
8241-04032	1 1/2" x 1 1/4"	49,5	40	20,5	6,5	90	5
8241-05015	2" x 1/2"	61,5	51	25	7	60	1
8241-05020	2" x 3/4"	61,5	51	25	7	60	1
8241-05025	2" x 1"	61,5	51	25	7	60	1
8241-05032	2" x 1 1/4"	61,5	51	25	7	60	1
8241-05040	2" x 1 1/2"	61,5	51	25	7	60	1
8241-06525	2 1/2" x 1"	77,5	51	27	7	24	1
8241-06540	2 1/2" x 1 1/2"	77,5	65,5	27	7	24	1
8241-06550	2 1/2" x 2"	77,5	65,5	27	7	24	1
8241-08040	3" x 1 1/2"	90,5	77,5	30	7,5	20	1
8241-08050	3" x 2"	90,5	77,5	30	7,5	20	1
8241-08065	3" x 2 1/2"	90,5	77,5	30	7,5	20	v1
8241-10050	4" x 2"	116,5	77,5	36	8	10	1
8241-10065	4" x 2 1/2"	116,5	101,5	36	8	10	1
8241-10080	4" x 3"	116,5	101,5	36	8	10	1

8280

Machón M-M

EAN CODE

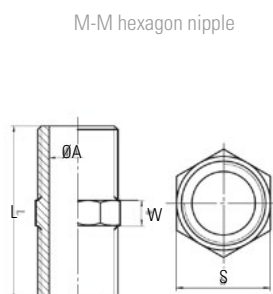

CÓDIGO CODE	MEDIDA SIZE	ØA	L	S	W		
8280-006	1/8"	5,5	28	12	7	1000	10
8280-008	1/4"	8	25	14	4,5	1000	10
8280-010	3/8"	11,5	27	18	5,5	600	10
8280-015	1/2"	15	34	22	5,5	380	10
8280-020	3/4"	20,5	36,5	28	5,5	200	10
8280-025	1"	26	42	34	6	140	5
8280-032	1 1/4"	34,5	47,5	44	6,5	60	5
8280-040	1 1/2"	40	47,5	50	6,5	50	5
8280-050	2"	51	57	61,5	7	36	1
8280-065	2 1/2"	65,5	61	77	7	18	1
8280-080	3"	77,5	67,5	90	7,5	12	1
8280-100	4"	103	80	120	8	4	1

8245

Machón reducido M-M

EAN CODE



M-M hexagon nipple reduced

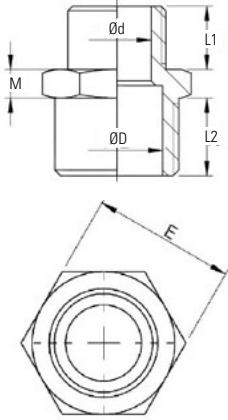

CÓDIGO CODE	MEDIDA SIZE	L1	L2	M	D	d	E	📦	📦
8245-00806	1/4" x 1/8"	8	10,5	4	8	5,5	14,5	800	10
8245-01006	3/8" x 1/8"	8	11	5	11,5	5,5	19	650	10
8245-01008	3/8" x 1/4"	11	11	5	11,5	8	19	650	10
8245-01506	1/2" x 1/8"	9	14,5	5	15,5	5,5	23	400	10
8245-01508	1/2" x 1/4"	11	14,5	5	15	8	23	400	10
8245-01510	1/2" x 3/8"	11	14,5	5	15	11,5	23	400	10
8245-02008	3/4" x 1/4"	12	15,5	5,5	21	8	28	300	10
8245-02010	3/4" x 3/8"	11	15,5	5,5	20,5	11,5	28	300	10
8245-02015	3/4" x 1/2"	14,5	15,5	5,5	20,5	15	28	300	10
8245-02508	1" x 1/4"	13,5	19	11	25,5	8	35	200	5
8245-02510	1" x 3/8"	13,5	18	7,5	26	11,5	35	200	5
8245-02515	1" x 1/2"	14,5	18	6	26	15	35	200	5
8245-02520	1" x 3/4"	15,5	18	6,5	26	20,5	35	200	5
8245-03215	1 1/4" x 1/2"	14,5	20,5	6,5	35	15	44	100	5
8245-03220	1 1/4" x 3/4"	15,5	20,5	6,5	34,5	20,5	44	100	5
8245-03225	1 1/4" x 1"	18	20,5	6,5	26	34,5	44	100	5
8245-04010	1 1/2" x 3/8"	13,5	20,5	6,5	40	12	51	80	5
8245-04015	1 1/2" x 1/2"	15	20,5	6,5	40	15	51	80	5
8245-04020	1 1/2" x 3/4"	15,5	20,5	6,5	40	20,5	51	70	5
8245-04025	1 1/2" x 1"	18	20,5	6,5	40	26	51	70	5
8245-04032	1 1/2" x 1 1/4"	20,5	20,5	6,5	40	34,5	51	50	5
8245-05015	2" x 1/2"	13,5	25	7	52	15,5	62	48	1
8245-05020	2" x 3/4"	15	25	7	52,5	21	62	48	1
8245-05025	2" x 1"	18	25	7	53	27	62	48	1
8245-05032	2" x 1 1/4"	20,5	25	7	51	34,5	62	48	1
8245-05040	2" x 1 1/2"	20,5	25	7	51	40	62	48	1
8245-06550	2 1/2" x 2"	25	27	7	65,5	51	78	20	1
8245-08050	3" x 2"	22	32	7,5	76,5	40	90,5	20	1
8245-08065	3" x 2 1/2"	25	30	8	77,5	51	90,5	20	1

8290

Tapón rosca M con reborde

EAN CODE



M hexagon plugs

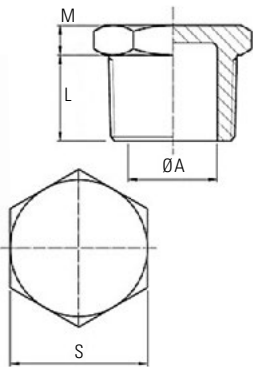

CÓDIGO CODE	MEDIDA SIZE	ØA	S	M	L	📦	📦
8290-008	1/4"	8	14,5	4	10,5	800	10
8290-010	3/8"	11,5	18	5	11	600	10
8290-015	1/2"	15	22	5	14,5	500	10
8290-020	3/4"	20,5	27,5	5,5	15,5	300	10
8290-025	1"	26	34,5	6	18	200	5
8290-032	1 1/4"	34,5	43,5	6,5	20,5	120	5
8290-040	1 1/2"	40	50,5	6,5	20,5	70	5
8290-050	2"	51	62,5	7	25	60	1
8290-065	2 1/2"	65,5	78,5	7	27	24	1
8290-080	3"	77,5	92	7,5	30	20	1
8290-100	4"	104	115,5	8	36	8	1

8300

Tapón hexagonal H

EAN CODE



F hexagon cap

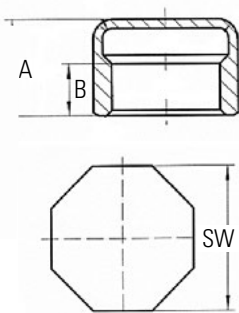

CÓDIGO CODE	MEDIDA SIZE	A	B	SW	📦	📦
8300-008	1/4"	16	14	16,5	1000	10
8300-010	3/8"	16,5	11,5	20	800	10
8300-015	1/2"	21	14,5	24,5	400	10
8300-020	3/4"	22	17	30	250	10
8300-025	1"	26	21	37	150	5
8300-032	1 1/4"	24	18	45,5	80	5
8300-040	1 1/2"	29	18	53	70	5
8300-050	2"	33	18	65	40	1
8300-065	2 1/2"	38	22	82	20	1
8300-080	3"	38,5	28	100	15	1
8300-100	4"	48	33	122	8	1

8312

Tuerca hexagonal

EAN CODE



Back nut

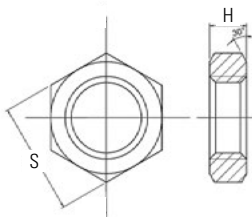

CÓDIGO CODE	MEDIDA SIZE	H	S	☐	☐
8312-008	1/4"	5,5	18	1000	10
8312-010	3/8"	6	23,5	1000	10
8312-015	1/2"	6,5	29,5	600	10
8312-020	3/4"	7	34	500	10
8312-025	1"	9	42,5	300	5
8312-032	1 1/4"	11	52	200	5
8312-040	1 1/2"	11	58	150	5
8312-050	2"	13	72	80	1

8330

Enlace tres piezas junta
plana PTFE H-H

EAN CODE



F-F three pieces union
PTFE flat seat

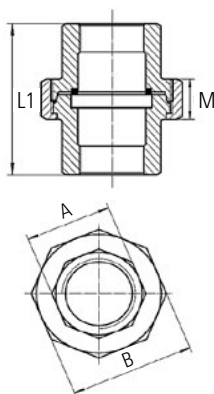

CÓDIGO CODE	MEDIDA SIZE	A	B	L1	M	☐	☐
8330-008	1/4"	16,5	29	33,5	13,5	200	10
8330-010	3/8"	20	34	36,5	15	120	10
8330-015	1/2"	24,5	37	40	16	100	10
8330-020	3/4"	30	44	42,5	17	70	10
8330-025	1"	37	52,5	50	20	40	5
8330-032	1 1/4"	46,5	64	54	22	30	5
8330-040	1 1/2"	53	70	58	24	25	5
8330-050	2"	65	84	65,5	27	15	1
8330-065	2 1/2"	85	108	75	29,5	8	1
8330-080	3"	96	118	83	31	6	1
8330-100	4"	125	152	110	34	3	1

- Asiento plano con junta PTFE
PTFE seat gasket

8340

Enlace tres piezas H-H

EAN CODE



F-F three pieces union

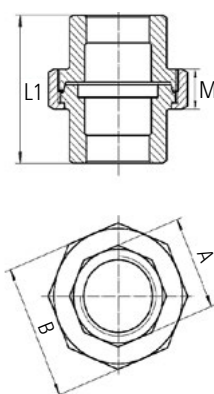

CÓDIGO CODE	MEDIDA SIZE	A	B	L1	M	☐	☐
8340-008	1/4"	16,5	29	33,5	13,5	200	10
8340-010	3/8"	20	34	36,5	15	120	10
8340-015	1/2"	24,5	37	40	16	100	10
8340-020	3/4"	30	44	42,5	17	70	10
8340-025	1"	37	52,5	50	20	40	10
8340-032	1 1/4"	46,5	64	54	22	30	5
8340-040	1 1/2"	53	70	58	24	25	5
8340-050	2"	65	84	65,5	27	15	5
8340-065	2 1/2"	82	101,5	75	29,5	8	1
8340-080	3"	96	118	83	31	6	1
8340-100	4"	125	152	90	31,5	3	1

- Asiento cónico
Tapered seat

8341

Enlace tres piezas M-H

EAN CODE



M-F three pieces union

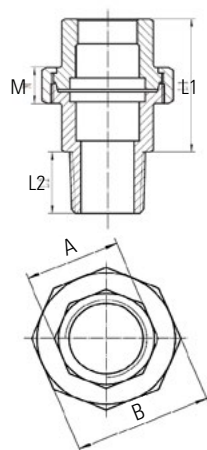

CÓDIGO CODE	MEDIDA SIZE	A	B	L1	L2	M	☐	☐
8341-008	1/4"	16,5	29	33,5	10,5	13,5	150	10
8341-010	3/8"	20	34	36,5	11	15	120	10
8341-015	1/2"	24,5	37	39,5	14,5	16	100	10
8341-020	3/4"	30	44	42,5	15,5	17	50	10
8341-025	1"	37	52,5	50	18	20	40	5
8341-032	1 1/4"	46,5	63	54	20,5	22	20	5
8341-040	1 1/2"	53	70	58	20,5	24	15	5
8341-050	2"	65	84	65	25	27	10	1
8341-065	2 1/2"	82	101,5	75	27	29,5	6	1
8341-080	3"	95,5	118	83	30	31	3	1
8341-100	4"	121,5	148,5	110	36	34	2	1

- Asiento cónico
Tapered seat

8399

Entronque manguera

Hexagon hose nipple

EAN CODE

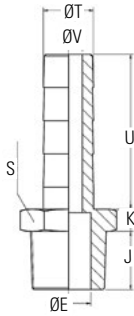

CÓDIGO CODE	MEDIDA SIZE	E	J	K	U	V	T	S		
8399-008	1/4" x 9	8	10,5	4	28	5	9	15	600	10
8399-010	3/8" x 11,5	11,5	11	5	33	7	11,5	18,5	500	10
8399-015	1/2" x 15	16	14	7	27	8,5	15	22	350	10
8399-020	3/4" x 20	20,5	15,5	5,5	45	15	20	28	150	10
8399-025	1" x 27	26	18	6	52	22	27	34	100	5
8399-032	1 1/4" x 33	34,5	20,5	6,5	52	27,5	33	44	50	5
8399-040	1 1/2" x 40	40	20	6,5	55	34	39	49,5	30	5
8399-050	2" x 53	51	25	7,5	60	45,5	52	61,5	20	1

8531

Manguito interior

Running nipple

EAN CODE

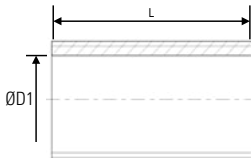

CÓDIGO CODE	MEDIDA SIZE	ØD1	L		
8531-008	1/4"	9,5	18	400	10
8531-010	3/8"	12,2	22	400	10
8531-015	1/2"	16,6	25	400	10
8531-020	3/4"	21,5	30	250	10
8531-025	1"	27	35	100	5
8531-032	1 1/4"	35,7	38	100	5
8531-040	1 1/2"	41,2	38	80	5
8531-050	2"	53	45	20	1
8531-065	2 1/2"	69,3	51	20	1
8531-080	3"	80,5	60	10	1
8531-100	4"	105,3	70	10	1

8601

Entronque rosca manguera

Threaded hose coupling

EAN CODE

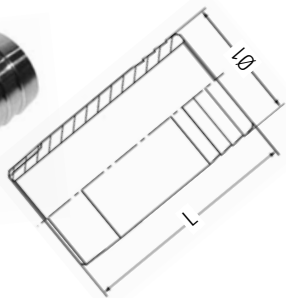

CÓDIGO CODE	MEDIDA SIZE	Ø1	L		
8601-008	1/4"	13,5	70	400	10
8601-010	3/8"	17,2	70	200	10
8601-015	1/2"	21,3	70	200	10
8601-020	3/4"	26,9	70	120	10
8601-025	1"	33,7	70	50	5
8601-032	1 1/4"	42,4	70	30	1
8601-040	1 1/2"	48,3	100	20	5
8601-050	2"	60,3	100	18	1

8602

Entronque doble manguera

Hose coupling

EAN CODE

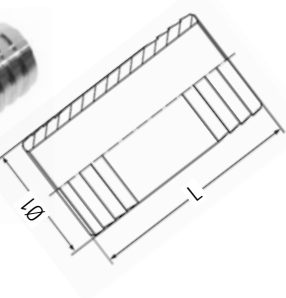

CÓDIGO CODE	MEDIDA SIZE	Ø1	L		
8602-008	1/4"	13,5	66	400	10
8602-010	3/8"	17,2	76	200	10
8602-015	1/2"	21,3	86	200	10
8602-020	3/4"	26,9	100	100	10
8602-025	1"	33,7	114	50	5
8602-032	1 1/4"	42,4	114	35	1
8602-040	1 1/2"	48,3	122	25	1
8602-050	2"	60,3	130	25	1

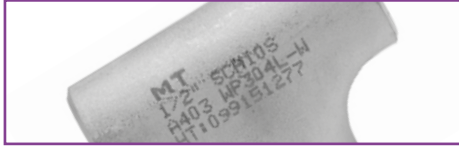

**SOLDADOS
WELDED**



FICHA TÉCNICA
TECHNICAL SHEET



**S09014
SCH 10 A-304L**

Codo 90° radio largo

Elbow 90° long radius

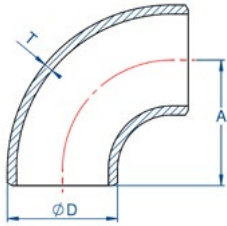

CÓDIGO CODE	MEDIDA SIZE	D	T Sch 10	A	
S09014-015	1/2"	21,34	2,11	38,1	1
S09014-020	3/4"	26,67	2,11	38,1	1
S09014-025	1"	33,4	2,77	38,1	1
S09014-032	1 1/4"	42,16	2,77	47,75	1
S09014-040	1 1/2"	48,26	2,77	57,15	1
S09014-050	2"	60,33	2,77	76,2	1
S09014-065	2 1/2"	73,03	3,05	95,25	1
S09014-080	3"	88,9	3,05	114,3	1
S09014-100	4"	114,3	3,05	152,4	1
S09014-125	5"	141,3	3,4	190,5	1
S09014-150	6"	168,28	3,4	228,6	1
S09014-200	8"	219,08	3,76	304,08	1
S09014-250	10"	273,05	4,19	381	1
S09014-300	12"	323,85	4,57	457,2	1

**S09016
SCH 10 A-316L**

Codo 90° radio largo

Elbow 90° long radius

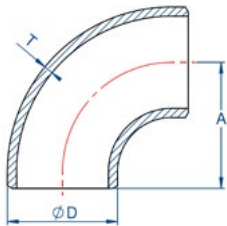

CÓDIGO CODE	MEDIDA SIZE	D	T Sch 10	A	
S09016-015	1/2"	21,34	2,11	38,1	1
S09016-020	3/4"	26,67	2,11	38,1	1
S09016-025	1"	33,4	2,77	38,1	1
S09016-032	1 1/4"	42,16	2,77	47,75	1
S09016-040	1 1/2"	48,26	2,77	57,15	1
S09016-050	2"	60,33	2,77	76,2	1
S09016-065	2 1/2"	73,03	3,05	95,25	1
S09016-080	3"	88,9	3,05	114,3	1
S09016-100	4"	114,3	3,05	152,4	1
S09016-125	5"	141,3	3,4	190,5	1
S09016-150	6"	168,28	3,4	228,6	1
S09016-200	8"	219,08	3,76	304,08	1
S09016-250	10"	273,05	4,19	381	1
S09016-300	12"	323,85	4,57	457,2	1

SS09016
SCH 10 A-316L

Codo 90° radio largo sin soldadura

Elbow 90° long radius seamless

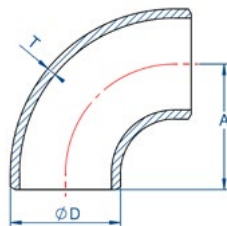

CÓDIGO CODE	MEDIDA SIZE	D1	D2	H	Sch 10		
					T1	T2	
SS09016-015	1/2"	26,67	21,34	38	2,87	2,77	1
SS09016-020	3/4"	33,4	21,34	51	3,38	2,77	1
SS09016-025	1"	33,4	26,67	51	3,38	2,87	1
SS09016-032	1 1/4"	42,16	26,67	51	3,56	2,87	1
SS09016-040	1 1/2"	42,16	33,4	51	3,56	3,38	1
SS09016-050	2"	48,26	26,67	64	3,68	2,87	1
SS09016-065	2 1/2"	48,26	33,4	64	3,68	3,38	1
SS09016-080	3"	48,26	42,16	64	3,68	3,56	1

S13014

SCH 10 A-304L

Te



Tee

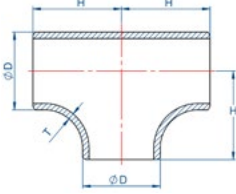

CÓDIGO CODE	MEDIDA SIZE	D	T Sch 10	H	
S13014-015	1/2"	21,34	2,11	25	1
S13014-020	3/4"	26,67	2,11	29	1
S13014-025	1"	33,4	2,77	38	1
S13014-032	1 1/4"	42,16	2,77	48	1
S13014-040	1 1/2"	48,26	2,77	57	1
S13014-050	2"	60,33	2,77	64	1
S13014-065	2 1/2"	73,03	3,05	75	1
S13014-080	3"	88,9	3,05	86	1
S13014-100	4"	114,3	3,05	105	1
S13014-125	5"	141,3	3,4	124	1
S13014-150	6"	168,28	3,4	143	1
S13014-200	8"	219,08	3,76	178	1
S13014-250	10"	273,05	4,19	216	1
S13014-300	12"	323,85	4,57	254	1

S13016

SCH 10 A-316L

Te



Tee

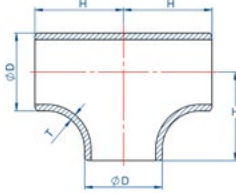

CÓDIGO CODE	MEDIDA SIZE	D	T Sch 10	H	
S13016-015	1/2"	21,34	2,11	25	1
S13016-020	3/4"	26,67	2,11	29	1
S13016-025	1"	33,4	2,77	38	1
S13016-032	1 1/4"	42,16	2,77	48	1
S13016-040	1 1/2"	48,26	2,77	57	1
S13016-050	2"	60,33	2,77	64	1
S13016-065	2 1/2"	73,03	3,05	75	1
S13016-080	3"	88,9	3,05	86	1
S13016-100	4"	114,3	3,05	105	1
S13016-125	5"	141,3	3,4	124	1
S13016-150	6"	168,28	3,4	143	1
S13016-200	8"	219,08	3,76	178	1
S13016-250	10"	273,05	4,19	216	1
S13016-300	12"	323,85	4,57	254	1

SS13016

SCH 10 A-316L



Te sin soldadura



Tee seamless

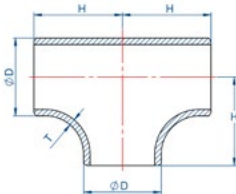

CÓDIGO CODE	MEDIDA SIZE	D1	D2	H	Sch 10		
					T1	T2	
SS13016-015	1/2"	26,67	21,34	38	2,87	2,77	1
SS13016-020	3/4"	33,4	21,34	51	3,38	2,77	1
SS13016-025	1"	33,4	26,67	51	3,38	2,87	1
SS13016-032	1 1/4"	42,16	26,67	51	3,56	2,87	1
SS13016-040	1 1/2"	42,16	33,4	51	3,56	3,38	1
SS13016-050	2"	48,26	26,67	64	3,68	2,87	1
SS13016-065	2 1/2"	48,26	33,4	64	3,68	3,38	1
SS13016-080	3"	48,26	42,16	64	3,68	3,56	1

S29614

SCH 10 A-304L

Stub end tipo A



Stub end A type

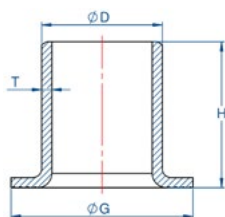

CÓDIGO CODE	MEDIDA SIZE	D	G	T Sch 10	H	
S29614-015	1/2"	21,34	35	2,11	51	1
S29614-020	3/4"	26,67	43	2,11	51	1
S29614-025	1"	33,4	50,8	2,77	51	1
S29614-032	1 1/4"	42,16	63,5	2,77	51	1
S29614-040	1 1/2"	48,26	73	2,77	51	1
S29614-050	2"	60,33	92	2,77	63,5	1
S29614-065	2 1/2"	73,03	105	3,05	63,5	1
S29614-080	3"	88,9	127	3,05	63,5	1
S29614-100	4"	114,3	157	3,05	76	1

S29616

SCH 10 A-316L

Stub end tipo A



Stub end A type

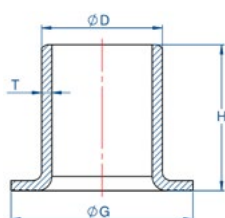

CÓDIGO CODE	MEDIDA SIZE	D	G	T Sch 10	H	
S29616-015	1/2"	21,34	35	2,11	51	1
S29616-020	3/4"	26,67	43	2,11	51	1
S29616-025	1"	33,4	50,8	2,77	51	1
S29616-032	1 1/4"	42,16	63,5	2,77	51	1
S29616-040	1 1/2"	48,26	73	2,77	51	1
S29616-050	2"	60,33	92	2,77	63,5	1
S29616-065	2 1/2"	73,03	105	3,05	63,5	1
S29616-080	3"	88,9	127	3,05	63,5	1
S29616-100	4"	114,3	157	3,05	76	1

S24014

SCH 10 A-304L

Reducción concéntrica



Concentric reducer

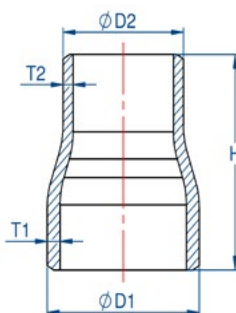

CÓDIGO CODE	MEDIDA SIZE	D1	D2	H	Sch 10		
					T1	T2	
S24014-020015	3/4" x 1/2"	26,67	21,34	38	2,11	2,11	1
S24014-025015	1" x 1/2"	33,4	21,34	51	2,77	2,11	1
S24014-025020	1" x 3/4"	33,4	26,67	51	2,77	2,11	1
S24014-032020	1 1/4" x 3/4"	42,16	26,67	51	2,77	2,11	1
S24014-032025	1 1/4" x 1"	42,16	33,4	51	2,77	2,77	1
S24014-040020	1 1/2" x 3/4"	48,26	26,67	64	2,77	2,11	1
S24014-040025	1 1/2" x 1"	48,26	33,4	64	2,77	2,77	1
S24014-040032	1 1/2" x 1 1/4"	48,26	42,16	64	2,77	2,77	1
S24014-050020	2" x 3/4"	60,32	26,67	76	2,77	2,11	1
S24014-050025	2" x 1"	60,32	33,4	76	2,77	2,77	1
S24014-050032	2" x 1 1/4"	60,32	42,16	76	2,77	2,77	1
S24014-050040	2" x 1 1/2"	60,32	48,26	76	2,77	2,77	1
S24014-065025	2 1/2" x 1"	73,02	33,4	89	3,05	2,77	1
S24014-065032	2 1/2" x 1 1/4"	73,02	42,16	89	3,05	2,77	1
S24014-065040	2 1/2" x 1 1/2"	73,02	48,26	89	3,05	2,77	1
S24014-065050	2 1/2" x 2"	73,02	60,32	89	3,05	2,77	1
S24014-080040	3" x 1 1/2"	88,9	48,26	89	3,05	2,77	1
S24014-080050	3" x 2"	88,9	60,32	89	3,05	2,77	1
S24014-080065	3" x 2 1/2"	88,9	73,02	89	3,05	3,05	1
S24014-100050	4" x 2"	114,3	60,32	102	3,05	2,77	1
S24014-100065	4" x 2 1/2"	114,3	73,02	102	3,05	3,05	1
S24014-100080	4" x 3"	114,3	88,9	102	3,05	3,05	1
S24014-125080	5" x 3"	141,3	88,9	127	3,4	3,05	1
S24014-125100	5" x 4"	141,3	114,3	127	3,4	3,05	1
S24014-150100	6" x 4"	168,27	114,3	140	3,4	3,05	1
S24014-150125	6" x 5"	168,27	141,3	140	3,4	3,4	1
S24014-200100	8" x 4"	219,08	114,3	152	3,76	3,05	1
S24014-200125	8" x 5"	219,08	141,3	152	3,76	3,4	1
S24014-200150	8" x 6"	219,08	168,27	152	3,76	3,4	1
S24014-250200	10" x 8"	273,05	219,08	178	4,19	3,76	1
S24014-300250	12" x 10"	323,85	273,05	203	4,57	4,19	1

S24016
SCH 10 A-316L

Reducción concéntrica

Concentric reducer

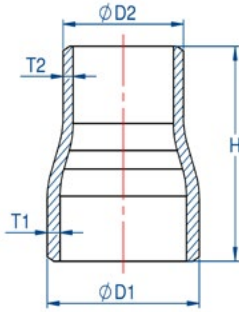

CÓDIGO CODE	MEDIDA SIZE	D1	D2	H	Sch 10		📦
					T1	T2	
S24016-020015	3/4" x 1/2"	26,67	21,34	38	2,11	2,11	1
S24016-025015	1" x 1/2"	33,4	21,34	51	2,77	2,11	1
S24016-025020	1" x 3/4"	33,4	26,67	51	2,77	2,11	1
S24016-032020	1 1/4" x 3/4"	42,16	26,67	51	2,77	2,11	1
S24016-032025	1 1/4" x 1"	42,16	33,4	51	2,77	2,77	1
S24016-040020	1 1/2" x 3/4"	48,26	26,67	64	2,77	2,11	1
S24016-040025	1 1/2" x 1"	48,26	33,4	64	2,77	2,77	1
S24016-040032	1 1/2" x 1 1/4"	48,26	42,16	64	2,77	2,77	1
S24016-050020	2" x 3/4"	60,32	26,67	76	2,77	2,11	1
S24016-050025	2" x 1"	60,32	33,4	76	2,77	2,77	1
S24016-050032	2" x 1 1/4"	60,32	42,16	76	2,77	2,77	1
S24016-050040	2" x 1 1/2"	60,32	48,26	76	2,77	2,77	1
S24016-065025	2 1/2" x 1"	73,02	33,4	89	3,05	2,77	1
S24016-065032	2 1/2" x 1 1/4"	73,02	42,16	89	3,05	2,77	1
S24016-065040	2 1/2" x 1 1/2"	73,02	48,26	89	3,05	2,77	1
S24016-065025	2 1/2" x 1"	73,02	33,4	89	3,05	2,77	1
S24016-065032	2 1/2" x 1 1/4"	73,02	42,16	89	3,05	2,77	1
S24016-065040	2 1/2" x 1 1/2"	73,02	48,26	89	3,05	2,77	1
S24016-065050	2 1/2" x 2"	73,02	60,32	89	3,05	2,77	1
S24016-080040	3" x 1 1/2"	88,9	48,26	89	3,05	2,77	1
S24016-080050	3" x 2"	88,9	60,32	89	3,05	2,77	1
S24016-080065	3" x 2 1/2"	88,9	73,02	89	3,05	3,05	1
S24016-100050	4" x 2"	114,3	60,32	102	3,05	2,77	1
S24016-100065	4" x 2 1/2"	114,3	73,02	102	3,05	3,05	1
S24016-100080	4" x 3"	114,3	88,9	102	3,05	3,05	1
S24016-125080	5" x 3"	141,3	88,9	127	3,4	3,05	1
S24016-125100	5" x 4"	141,3	114,3	127	3,4	3,05	1
S24016-150100	6" x 4"	168,27	114,3	140	3,4	3,05	1
S24016-150125	6" x 5"	168,27	141,3	140	3,4	3,4	1
S24016-200100	8" x 4"	219,08	114,3	152	3,76	3,05	1
S24016-200125	8" x 5"	219,08	141,3	152	3,76	3,4	1
S24016-200150	8" x 6"	219,08	168,27	152	3,76	3,4	1
S24016-250200	10" x 8"	273,05	219,08	178	4,19	3,76	1
S24016-300250	12" x 10"	323,85	273,05	203	4,57	4,19	1

SS24016 NEW
SCH 10 A-316L

Reducción concéntrica
sin soldadura

Concentric reducer
seamless

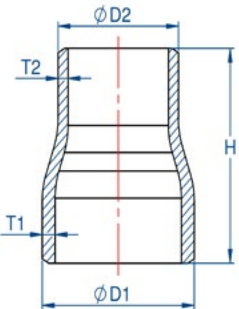

CÓDIGO CODE	MEDIDA SIZE	D1	D2	H	Sch 10		📦
					T1	T2	
SS24016-025015	1" x 1/2"	26,67	21,34	38	2,87	2,77	1
SS24016-025020	1" x 3/4"	33,4	21,34	51	3,38	2,77	1
SS24016-032020	1 1/4" x 3/4"	33,4	26,67	51	3,38	2,87	1
SS24016-032025	1 1/4" x 1"	42,16	26,67	51	3,56	2,87	1
SS24016-040020	1 1/2" x 3/4"	42,16	33,4	51	3,56	3,38	1
SS24016-040025	1 1/2" x 1"	48,26	26,67	64	3,68	2,87	1
SS24016-040032	1 1/2" x 1 1/4"	48,26	33,4	64	3,68	3,38	1
SS24016-050025	2" x 1"	48,26	42,16	64	3,68	3,56	1
SS24016-050032	2" x 1 1/4"	48,26	42,16	64	3,68	3,56	1
SS24016-050040	2" x 1 1/2"	48,26	42,16	64	3,68	3,56	1
SS24016-065050	2 1/2" x 2"	48,26	42,16	64	3,68	3,56	1
SS24016-080040	3" x 1 1/2"	48,26	42,16	64	3,68	3,56	1
SS24016-080050	3" x 2"	48,26	42,16	64	3,68	3,56	1
SS24016-080065	3" x 2 1/2"	48,26	42,16	64	3,68	3,56	1

S29014

SCH 10 A-304L

Tapón

Cap

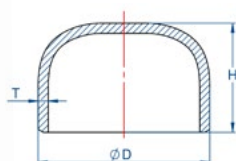

CÓDIGO CODE	MEDIDA SIZE	D	T Sch 10	H	
S29014-015	1/2"	21,34	2,11	25	1
S29014-020	3/4"	26,67	2,11	25	1
S29014-025	1"	33,4	2,77	38	1
S29014-032	1 1/4"	42,16	2,77	38	1
S29014-040	1 1/2"	48,26	2,77	38	1
S29014-050	2"	60,33	2,77	38	1
S29014-065	2 1/2"	73,03	3,05	38	1
S29014-080	3"	88,9	3,05	51	1
S29014-100	4"	114,3	3,05	64	1
S29014-125	5"	141,3	3,4	76	1
S29014-150	6"	168,28	3,4	89	1
S29014-200	8"	219,08	3,76	102	1
S29014-250	10"	273,05	4,19	127	1
S29014-300	12"	323,85	4,57	152	1

S29016

SCH 10 A-316L

Tapón

Cap

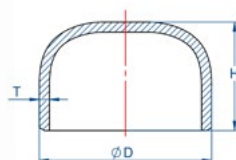

CÓDIGO CODE	MEDIDA SIZE	D	T Sch 10	H	
S29016-015	1/2"	21,34	2,11	25	1
S29016-020	3/4"	26,67	2,11	25	1
S29016-025	1"	33,4	2,77	38	1
S29016-032	1 1/4"	42,16	2,77	38	1
S29016-040	1 1/2"	48,26	2,77	38	1
S29016-050	2"	60,33	2,77	38	1
S29016-065	2 1/2"	73,03	3,05	38	1
S29016-080	3"	88,9	3,05	51	1
S29016-100	4"	114,3	3,05	64	1
S29016-125	5"	141,3	3,4	76	1
S29016-150	6"	168,28	3,4	89	1
S29016-200	8"	219,08	3,76	102	1
S29016-250	10"	273,05	4,19	127	1
S29016-300	12"	323,85	4,57	152	1

S09046

SCH 40 A-316L

Codo 90° radio largo

Elbow 90° long radius

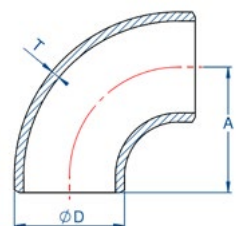

CÓDIGO CODE	MEDIDA SIZE	D	T Sch 40	A	
S09046-015	1/2"	21,34	2,77	38,1	1
S09046-020	3/4"	26,67	2,87	38,1	1
S09046-025	1"	33,4	3,38	38,1	1
S09046-032	1 1/4"	42,16	3,56	47,75	1
S09046-040	1 1/2"	48,26	3,68	57,15	1
S09046-050	2"	60,33	3,91	76,2	1
S09046-065	2 1/2"	73,03	5,16	95,25	1
S09046-080	3"	88,9	5,49	114,3	1
S09046-100	4"	114,3	6,02	152,4	1
S09046-125	5"	141,3	6,55	190,5	1
S09046-150	6"	168,28	7,11	228,6	1
S09046-200	8"	219,08	8,18	304,08	1
S09046-250	10"	273,05	9,27	381	1

S13046

SCH 40 A-316L

Te

Tee

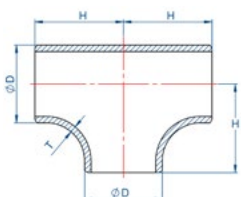

CÓDIGO CODE	MEDIDA SIZE	D	T Sch 40	H	
S13046-015	1/2"	21,34	2,77	25	1
S13046-020	3/4"	26,67	2,87	29	1
S13046-025	1"	33,4	3,38	38	1
S13046-032	1 1/4"	42,16	3,56	48	1
S13046-040	1 1/2"	48,26	3,68	57	1
S13046-050	2"	60,33	3,91	64	1
S13046-065	2 1/2"	73,03	5,16	75	1
S13046-080	3"	88,9	5,49	86	1
S13046-100	4"	114,3	6,02	105	1
S13046-125	5"	141,3	6,55	124	1
S13046-150	6"	168,28	7,11	143	1
S13046-200	8"	219,08	8,18	178	1
S13046-250	10"	273,05	9,27	216	1

S29046
SCH 40 A-316L

Tapón

Cap

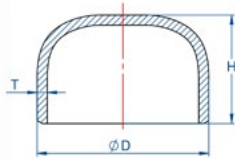

CÓDIGO CODE	MEDIDA SIZE	D	T Sch 40	H	☐
S29046-015	1/2"	21,34	2,77	25	1
S29046-020	3/4"	26,67	2,87	25	1
S29046-025	1"	33,4	3,38	38	1
S29046-032	1 1/4"	42,16	3,56	38	1
S29046-040	1 1/2"	48,26	3,68	38	1
S29046-050	2"	60,33	3,91	38	1
S29046-065	2 1/2"	73,03	5,16	38	1
S29046-080	3"	88,9	5,49	51	1
S29046-100	4"	114,3	6,02	64	1
S29046-125	5"	141,3	6,55	76	1
S29046-150	6"	168,28	7,11	89	1
S29046-200	8"	219,08	8,18	102	1
S29046-250	10"	273,05	9,27	127	1

S29646
SCH 40 A-316L

Stub end tipo A

Stub end A type

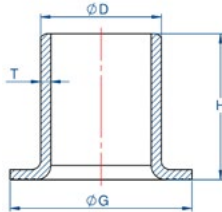

CÓDIGO CODE	MEDIDA SIZE	D	G	H	T Sch 40	☐
S29646-015	1/2"	21,34	35	51	2,77	1
S29646-020	3/4"	26,67	43	51	2,87	1
S29646-025	1"	33,4	50,8	51	3,38	1
S29646-032	1 1/4"	42,16	63,5	51	3,56	1
S29646-040	1 1/2"	48,26	73	51	3,68	1
S29646-050	2"	60,33	92	63,5	3,91	1
S29646-065	2 1/2"	73,03	105	63,5	5,16	1
S29646-080	3"	88,9	127	63,5	5,49	1
S29646-100	4"	114,3	157	76	6,02	1

S24046
SCH 40 A-316L

Reducción concéntrica

Concentric reducer

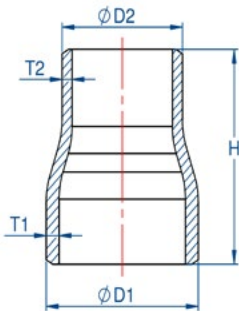

CÓDIGO CODE	MEDIDA SIZE	D1	D2	H	Sch 40		☐
					T1	T2	
S24046-020015	3/4" x 1/2"	26,67	21,34	38	2,87	2,77	1
S24046-025015	1" x 1/2"	33,4	21,34	51	3,38	2,77	1
S24046-025020	1" x 3/4"	33,4	26,67	51	3,38	2,87	1
S24046-032020	1 1/4" x 3/4"	42,16	26,67	51	3,56	2,87	1
S24046-032025	1 1/4" x 1"	42,16	33,4	51	3,56	3,38	1
S24046-040020	1 1/2" x 3/4"	48,26	26,67	64	3,68	2,87	1
S24046-040025	1 1/2" x 1"	48,26	33,4	64	3,68	3,38	1
S24046-040032	1 1/2" x 1 1/4"	48,26	42,16	64	3,68	3,56	1
S24046-050020	2" x 3/4"	60,32	26,67	76	3,91	2,87	1
S24046-050025	2" x 1"	60,32	33,4	76	3,91	3,38	1
S24046-050032	2" x 1 1/4"	60,32	42,16	76	3,91	3,56	1
S24046-050040	2" x 1 1/2"	60,32	48,26	76	3,91	3,68	1
S24046-065025	2 1/2" x 1"	73,02	33,4	89	5,16	3,38	1
S24046-065032	2 1/2" x 1 1/4"	73,02	42,16	89	5,16	3,56	1
S24046-065040	2 1/2" x 1 1/2"	73,02	48,26	89	5,16	3,68	1
S24046-065050	2 1/2" x 2"	73,02	60,32	89	5,16	3,91	1
S24046-080040	3" x 1 1/2"	88,9	48,26	89	5,49	3,68	1
S24046-080050	3" x 2"	88,9	60,32	89	5,49	3,91	1
S24046-080065	3" x 2 1/2"	88,9	73,02	89	5,49	5,16	1
S24046-100050	4" x 2"	114,3	60,32	102	6,02	3,91	1
S24046-100065	4" x 2 1/2"	114,3	73,02	102	6,02	5,16	1
S24046-100080	4" x 3"	114,3	88,9	102	6,02	5,49	1
S24046-125080	5" x 3"	141,3	88,9	127	6,55	5,49	1
S24046-125100	5" x 4"	141,3	114,3	127	6,55	6,02	1
S24046-150100	6" x 4"	168,27	114,3	140	7,11	6,02	1
S24046-150125	6" x 5"	168,27	141,3	140	7,11	6,55	1
S24046-200100	8" x 4"	219,08	114,3	152	8,18	6,02	1
S24046-200125	8" x 5"	219,08	141,3	152	8,18	6,55	1
S24046-200150	8" x 6"	219,08	168,27	152	8,18	7,11	1
S24046-250200	10" x 8"	273,05	219,08	178	9,27	8,18	1

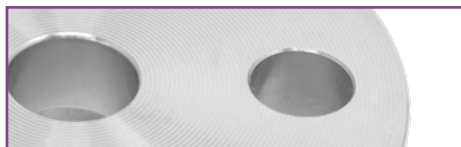

BRIDAS FLANGES

BRIDA PLANA PARA SOLDAR EN-1092-1 TIPO: 01A PN-10 PLATE FLANGE FOR WELDING EN-1092-1 TYPE: 01A PN-10
BRIDA FORJADA DE ACERO INOXIDABLE STAINLESS STEEL FORGET FLANGE

01A PN10 MM A304L

Brida forjada plana para soldar
Material: acero inoxidable EN 1.4307 / A304L
Tubo milimétrico

Plate flange for welding EN-1092-1 Type: 01A
Material: stainless steel EN 1.4307 / A304L
Milimetric pipe



CÓDIGO CODE	DN	PN
01A61014015	15	10-16-25-40
01A61014020	20	10-16-25-40
01A61014025	25	10-16-25-40
01A61014032	32	10-16-25-40
01A61014040	40	10-16-25-40
01A61014050	50	10-16
01A61014065	65	10-16
01A61014080	80	10-16
01A61014100	100	10-16
01A61014125	125	10-16
01A61014150	150	10-16
01A10014200	200	10
01A10014250	250	10
01A10014300	300	10
01A10004350	350	10
01A10004400	400	10
01A10004450	450	10
01A10004500	500	10
01A10004600	600	10
01A10004700	700	10
01A10004800	800	10
01A10004900	900	10
01A10004000	1000	10

01A PN10 MM A316L

Brida forjada plana para soldar
Material: acero inoxidable EN 1.4404 / A316L
Tubo milimétrico

Plate flange for welding EN-1092-1 Type: 01A
Material: stainless steel EN 1.4404 / A316L
Milimetric pipe



CÓDIGO CODE	DN	PN
01A61016015	15	10-16-25-40
01A61016020	20	10-16-25-40
01A61016025	25	10-16-25-40
01A61016032	32	10-16-25-40
01A61016040	40	10-16-25-40
01A61016050	50	10-16
01A61016065	65	10-16
01A61016080	80	10-16
01A61016100	100	10-16
01A61016125	125	10-16
01A61016150	150	10-16
01A10016200	200	10
01A10016250	250	10
01A10016300	300	10
01A10006350	350	10
01A10006400	400	10
01A10006450	450	10
01A10006500	500	10
01A10006600	600	10
01A10006700	700	10
01A10006800	800	10
01A10006900	900	10
01A10006000	1000	10

01A PN10 ISO A304L

Brida forjada plana para soldar
Material: acero inoxidable EN 1.4307 / A304L
Tubo ISO

Plate flange for welding EN-1092-1 Type: 01A
Material: stainless steel EN 1.4307 / A304L
ISO pipe



CÓDIGO CODE	DN	PN
01A61024015	15	10-16-25-40
01A61024020	20	10-16-25-40
01A61024025	25	10-16-25-40
01A61024032	32	10-16-25-40
01A61024040	40	10-16-25-40
01A61024050	50	10-16
01A61024065	65	10-16
01A61024080	80	10-16
01A61024100	100	10-16
01A61024125	125	10-16
01A61024150	150	10-16
01A10024200	200	10
01A10024250	250	10
01A10024300	300	10
01A10004350	350	10
01A10004400	400	10
01A10004450	450	10
01A10004500	500	10
01A10004600	600	10
01A10004700	700	10
01A10004800	800	10
01A10004900	900	10
01A10004000	1000	10

01A PN10 ISO A316L

Brida forjada plana para soldar
Material: acero inoxidable EN 1.4404 / A316L
Tubo ISO

Plate flange for welding EN-1092-1 Type: 01A
Material: stainless steel EN 1.4404 / A316L
ISO pipe



CÓDIGO CODE	DN	PN
01A61026015	15	10-16-25-40
01A61026020	20	10-16-25-40
01A61026025	25	10-16-25-40
01A61026032	32	10-16-25-40
01A61026040	40	10-16-25-40
01A61026050	50	10-16
01A61026065	65	10-16
01A61026080	80	10-16
01A61026100	100	10-16
01A61026125	125	10-16
01A61026150	150	10-16
01A10026200	200	10
01A10026250	250	10
01A10026300	300	10
01A10006350	350	10
01A10006400	400	10
01A10006450	450	10
01A10006500	500	10
01A10006600	600	10
01A10006700	700	10
01A10006800	800	10
01A10006900	900	10
01A10006000	1000	10



FICHA TÉCNICA
TECHNICAL SHEET

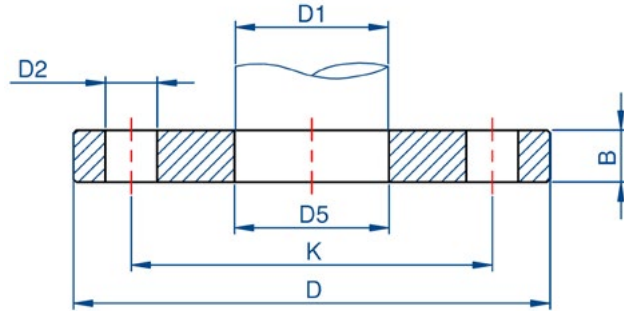

DN	PN	TUBO PIPE			BRIDA FLANGE			TORNILLOS BOLTS			PESO WEIGHT HT (7,85kg/m3)
		TIPO TYPE	D1	D5	D	B	K	nº	ROSCA THREAD	D2	
15	10-16-25-40	ISO	21,3	22	95	14	65	4	M12	14	0,67
		MM	18	18,5	95	14	65	4	M12	14	0,69
20	10-16-25-40	ISO	26,9	27,5	105	16	75	4	M12	14	0,94
		MM	23	23,5	105	16	75	4	M12	14	0,97
25	10-16-25-40	ISO	33,7	34,5	115	16	85	4	M12	14	1,11
		MM	28	28,5	115	16	85	4	M12	14	1,16
32	10-16-25-40	ISO	42,4	43,5	140	18 (16)	100	4	M16	18	1,62
		MM	38	38,5	140	18 (16)	100	4	M16	18	1,68
40	10-16-25-40	ISO	48,3	49,5	150	18 (16)	110	4	M16	18	1,86
		MM	43	43,5	150	18 (16)	110	4	M16	18	1,92
50	10-16	ISO	60,3	61,5	165	20 (18)	125	4	M16	18	2,47
		MM	53	53,5	165	20 (18)	125	4	M16	18	2,59
65	10-16	ISO	76,1	77,5	185	20 (18)	145	8 (4)	M16	18	3
		MM	73	73,7	185	20 (18)	145	8 (4)	M16	18	3,08
80	10-16	ISO	88,9	90,5	200	20	160	8	M16	18	3,79
		MM	84	84,7	200	20	160	8	M16	18	3,77
100	10-16	ISO	114,3	116	220	22 (20)	180	8	M16	18	4,03
		MM	104	104,8	220	22 (20)	180	8	M16	18	4,34
125	10-16	ISO	139,7	141,5	250	22	210	8	M16	18	5,46
		MM	129	130	250	22	210	8	M16	18	5,89
150	10-16	ISO	168,3	170,5	285	24 (22)	240	8	M20	22	6,57
		MM	154	156	285	24 (22)	240	8	M20	22	7,27
200	10	ISO	219,1	221,5	340	24	295	8	M20	22	9,31
		MM	204	206	340	24	295	8	M20	22	10,36
250	10	ISO	273	276,5	395	26	350	12	M20	22	11,9
		MM	254	256	395	26	350	12	M20	22	13,72
300	10	ISO	323,9	327,5	445	26	400	12	M20	22	13,8
		MM	304	307	445	26	400	12	M20	22	15,87
350	10	ISO	355,6	359,5	505	30 (28)	460	16	M20	22	20,6
		MM	354	359,5	505	30 (28)	460	16	M20	22	20,6
400	10	ISO	406,4	411	565	32	515	16	M24	26	27,9
		MM	406	411	565	32	515	16	M24	26	27,9
450	10	ISO	457	462,3	615	36 (38)	565	20	M24	26	35,6
		MM	457	462,3	615	36 (38)	565	20	M24	26	35,6
500	10	ISO	508	513,5	670	38	620	20	M24	26	41,1
		MM	506	513,5	670	38	620	20	M24	26	41,1
600	10	ISO	610	616,5	780	42 (40)	725	20	M27	30	52,87
		MM	610	616,5	780	42 (40)	725	20	M27	30	52,87
700	10	ISO	711	716	895	50 (40)	840	24	M27	30	66,48
		MM	711	716	895	50 (40)	840	24	M27	30	66,48
800	10	ISO	813	818	1015	56 (44)	950	24	M30	33	91,82
		MM	813	818	1015	56 (44)	950	24	M30	33	91,82
900	10	ISO	914	920	1115	62 (48)	1050	28	M30	33	109,55
		MM	914	920	1115	62 (48)	1050	28	M30	33	109,55
1000	10	ISO	1016	1022	1230	70 (50)	1160	28	M33	36	134,61
		MM	1016	1022	1230	70 (50)	1160	28	M33	36	134,61

• Valores entre paréntesis pertenecen a la DIN 2576
Values in parentheses belong to DIN 2576

BRIDA PLANA PARA SOLDAR EN-1092-1 TIPO: 01A PN-16 PLATE FLANGE FOR WELDING EN-1092-1 TYPE: 01A PN-16
BRIDA FORJADA DE ACERO INOXIDABLE STAINLESS STEEL FORGET FLANGE

01A PN16 MM A304L

Brida forjada plana para soldar
Material: acero inoxidable EN 1.4307 / A304L
Tubo milimétrico

Plate flange for welding EN-1092-1 Type: 01A
Material: stainless steel EN 1.4307 / A304L
Milimetric pipe



CÓDIGO CODE	DN	PN
01A61014015	15	10-16-25-40
01A61014020	20	10-16-25-40
01A61014025	25	10-16-25-40
01A61014032	32	10-16-25-40
01A61014040	40	10-16-25-40
01A61014050	50	10-16
01A61014065	65	10-16
01A61014080	80	10-16
01A61014100	100	10-16
01A61014125	125	10-16
01A61014150	150	10-16
01A16014200	200	16
01A16014250	250	16
01A16014300	300	16
01A16004350	350	16
01A16004400	400	16
01A16004500	500	16
01A16004600	600	16
01A16004700	700	16
01A16004800	800	16

01A PN16 MM A316L

Brida forjada plana para soldar
Material: acero inoxidable EN 1.4404 / A316L
Tubo milimétrico

Plate flange for welding EN-1092-1 Type: 01A
Material: stainless steel EN 1.4404 / A316L
Milimetric pipe



CÓDIGO CODE	DN	PN
01A61016015	15	10-16-25-40
01A61016020	20	10-16-25-40
01A61016025	25	10-16-25-40
01A61016032	32	10-16-25-40
01A61016040	40	10-16-25-40
01A61016050	50	10-16
01A61016065	65	10-16
01A61016080	80	10-16
01A61016100	100	10-16
01A61016125	125	10-16
01A61016150	150	10-16
01A16016200	200	16
01A16016250	250	16
01A16016300	300	16
01A16006350	350	16
01A16006400	400	16
01A16006500	500	16
01A16006600	600	16
01A16006700	700	16
01A16006800	800	16

01A PN16 ISO A304L

Brida forjada plana para soldar
Material: acero inoxidable EN 1.4307 / A304L
Tubo ISO

Plate flange for welding EN-1092-1 Type: 01A
Material: stainless steel EN 1.4307 / A304L
ISO pipe



CÓDIGO CODE	DN	PN
01A61024015	15	10-16-25-40
01A61024020	20	10-16-25-40
01A61024025	25	10-16-25-40
01A61024032	32	10-16-25-40
01A61024040	40	10-16-25-40
01A61024050	50	10-16
01A61024065	65	10-16
01A61024080	80	10-16
01A61024100	100	10-16
01A61024125	125	10-16
01A61024150	150	10-16
01A16024200	200	16
01A16024250	250	16
01A16024300	300	16
01A16004350	350	16
01A16004400	400	16
01A16004500	500	16
01A16004600	600	16
01A16004700	700	16
01A16004800	800	16

01A PN16 ISO A316L

Brida forjada plana para soldar
Material: acero inoxidable EN 1.4404 / A316L
Tubo ISO

Plate flange for welding EN-1092-1 Type: 01A
Material: stainless steel EN 1.4404 / A316L
ISO pipe



CÓDIGO CODE	DN	PN
01A61026015	15	10-16-25-40
01A61026020	20	10-16-25-40
01A61026025	25	10-16-25-40
01A61026032	32	10-16-25-40
01A61026040	40	10-16-25-40
01A61026050	50	10-16
01A61026065	65	10-16
01A61026080	80	10-16
01A61026100	100	10-16
01A61026125	125	10-16
01A61026150	150	10-16
01A16026200	200	16
01A16026250	250	16
01A16026300	300	16
01A16006350	350	16
01A16006400	400	16
01A16006500	500	16
01A16006600	600	16
01A16006700	700	16
01A16006800	800	16



FICHA TÉCNICA
TECHNICAL SHEET

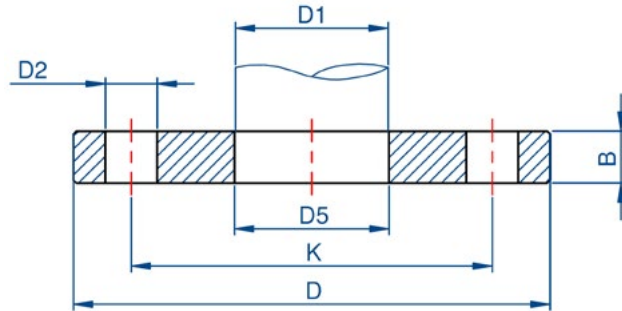

DN	PN	TUBO PIPE			BRIDA FLANGE			TORNILLOS BOLTS			PESO WEIGHT HT (7,85kg/m3)
		TIPO TYPE	D1	D5	D	B	K	nº ROSCA THREAD	D2		
15	10-16-25-40	ISO	21,3	22	95	14	65	4	M12	14	0,67
		MM	18	18,5	95	14	65	4	M12	14	0,69
20	10-16-25-40	ISO	26,9	27,5	105	16	75	4	M12	14	0,94
		MM	23	23,5	105	16	75	4	M12	14	0,97
25	10-16-25-40	ISO	33,7	34,5	115	16	85	4	M12	14	1,11
		MM	28	28,5	115	16	85	4	M12	14	1,16
32	10-16-25-40	ISO	42,4	43,5	140	18 (16)	100	4	M16	18	1,62
		MM	38	38,5	140	18 (16)	100	4	M16	18	1,68
40	10-16-25-40	ISO	48,3	49,5	150	18 (16)	110	4	M16	18	1,86
		MM	43	43,5	150	18 (16)	110	4	M16	18	1,92
50	10-16	ISO	60,3	61,5	165	20 (18)	125	4	M16	18	2,47
		MM	53	53,5	165	20 (18)	125	4	M16	18	2,59
65	10-16	ISO	76,1	77,5	185	20 (18)	145	8 (4)	M16	18	3
		MM	73	73,7	185	20 (18)	145	8 (4)	M16	18	3,08
80	10-16	ISO	88,9	90,5	200	20	160	8	M16	18	3,79
		MM	84	84,7	200	20	160	8	M16	18	3,77
100	10-16	ISO	114,3	116	220	22 (20)	180	8	M16	18	4,03
		MM	104	104,8	220	22 (20)	180	8	M16	18	4,34
125	10-16	ISO	139,7	141,5	250	22	210	8	M16	18	5,46
		MM	129	130	250	22	210	8	M16	18	5,89
150	10-16	ISO	168,3	170,5	285	24 (22)	240	8	M20	22	6,57
		MM	154	156	285	24 (22)	240	8	M20	22	7,27
200	16	ISO	219,1	221,5	340	26 (24)	295	12	M20	22	9,2
		MM	204	206	340	26 (24)	295	12	M20	22	10,07
250	16	ISO	273	276,5	405	29 (26)	355	12	M24	26	13,4
		MM	254	256	405	29 (26)	355	12	M24	26	14,64
300	16	ISO	323,9	327,5	460	32 (28)	410	12	M24	26	17,4
		MM	304	307	460	32 (28)	410	12	M24	26	19,06
350	16	ISO	355,6	359,5	520	35 (30)	470	16	M24	26	28,6
		MM	354	359,5	520	35 (30)	470	16	M24	26	28,6
400	16	ISO	406,4	411	580	38 (32)	525	16	M27	30	30,9
		MM	406	411	580	38 (32)	525	16	M27	30	30,9
500	16	ISO	508	513,5	715	46 (38)	650	20	M30	33	54
		MM	508	513,5	715	46 (38)	650	20	M30	33	54
600	16	ISO	610	616,5	840	55	770	20	M33	36	102
		MM	610	616,5	840	55	770	20	M33	36	102
700	16	ISO	711	716	910	63	840	24	M33	36	111
		MM	711	716	910	63	840	24	M33	36	111
800	16	ISO	813	818	1025	74	950	24	M36	39	158
		MM	813	818	1025	74	950	24	M36	39	158

- Valores entre paréntesis pertenecen a la DIN 2502
Values in parentheses belong to DIN 2502

BRIDA PLANA PARA SOLDAR EN-1092-1 TIPO: 01A PN-25 PLATE FLANGE FOR WELDING EN-1092-1 TYPE: 01A PN-25
BRIDA FORJADA DE ACERO INOXIDABLE STAINLESS STEEL FORGED FLANGE

01A PN25 ISO A304L

Brida forjada plana para soldar
Material: acero inoxidable EN 1.4307 / A304L
Tubo ISO

Plate flange for welding EN-1092-1 Type: 01A
Material: stainless steel EN 1.4307 / A304L
ISO pipe

NEW



CÓDIGO CODE	DN	PN
01A61024015	15	10-16-25-40
01A61024020	20	10-16-25-40
01A61024025	25	10-16-25-40
01A61024032	32	10-16-25-40
01A61024040	40	10-16-25-40
01A40024050	50	25-40
01A40024065	65	25-40
01A40024080	80	25-40
01A40024100	100	25-40
01A40024125	125	25-40
01A40024150	150	25-40
01A25024200	200	25
01A25024250	250	25
01A25024300	300	25

01A PN25 ISO A316L

Brida forjada plana para soldar
Material: acero inoxidable EN 1.4404 / A316L
Tubo ISO

Plate flange for welding EN-1092-1 Type: 01A
Material: stainless steel EN 1.4404 / A316L
ISO pipe

NEW



CÓDIGO CODE	DN	PN
01A61026015	15	10-16-25-40
01A61026020	20	10-16-25-40
01A61026025	25	10-16-25-40
01A61026032	32	10-16-25-40
01A61026040	40	10-16-25-40
01A40026050	50	25-40
01A40026065	65	25-40
01A40026080	80	25-40
01A40026100	100	25-40
01A40026125	125	25-40
01A40026150	150	25-40
01A25026200	200	25
01A25026250	250	25
01A25026300	300	25



FICHA TÉCNICA
TECHNICAL SHEET

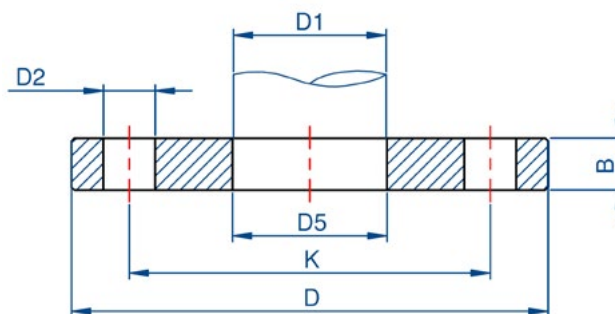

DN	PN	TUBO PIPE			BRIDA FLANGE			TORNILLOS BOLTS			PESO WEIGHT HT (7,85kg/m ³)
		TIPO TYPE	D1	D5	D	B	K	n°	ROSCA THREAD	D2	
15	10-16-25-40	ISO	21,3	22	95	14	65	4	M12	14	0,67
20	10-16-25-40	ISO	26,9	27,5	105	16	75	4	M12	14	0,94
25	10-16-25-40	ISO	33,7	34,5	115	16	85	4	M12	14	1,11
32	10-16-25-40	ISO	42,4	43,5	140	18	100	4	M16	18	1,82
40	10-16-25-40	ISO	48,3	49,5	150	18	110	4	M16	18	2,08
50	25-40	ISO	60,3	61,5	165	20	125	4	M16	18	2,73
65	25-40	ISO	76,1	77,5	185	22	145	8	M16	18	3,45
80	25-40	ISO	88,9	90,5	200	24	160	8	M16	18	4,32
100	25-40	ISO	114,3	116	235	26	190	8	M20	22	6,07
125	25-40	ISO	139,7	141,5	270	28	220	8	M24	26	8,19
150	25-40	ISO	168,3	170,5	300	30	250	8	M24	26	10,3
200	25	ISO	219,1	221,5	360	32	315	12	M24	26	14,3
250	25	ISO	273	276,5	425	35	370	12	M27	30	20,1
300	25	ISO	323,9	327,5	485	38	430	16	M27	30	26,6

BRIDA PLANA PARA SOLDAR EN-1092-1 TIPO: 01A PN-40 PLATE FLANGE FOR WELDING EN-1092-1 TYPE: 01A PN-40
BRIDA FORJADA DE ACERO INOXIDABLE STAINLESS STEEL FORGET FLANGE

01A PN40 ISO A304L

Brida forjada plana para soldar
Material: acero inoxidable EN 1.4307 / A304L
Tubo ISO

Plate flange for welding EN-1092-1 Type: 01A
Material: stainless steel EN 1.4307 / A304L
ISO pipe



CÓDIGO CODE	DN	PN
01A61024015	15	10-16-25-40
01A61024020	20	10-16-25-40
01A61024025	25	10-16-25-40
01A61024032	32	10-16-25-40
01A61024040	40	10-16-25-40
01A40024050	50	25-40
01A40024065	65	25-40
01A40024080	80	25-40
01A40024100	100	25-40
01A40024125	125	25-40
01A40024150	150	25-40
01A40024200	200	40
01A40024250	250	40
01A40024300	300	40

01A PN40 ISO A316L

Brida forjada plana para soldar
Material: acero inoxidable EN 1.4404 / A316L
Tubo ISO

Plate flange for welding EN-1092-1 Type: 01A
Material: stainless steel EN 1.4404 / A316L
ISO pipe



CÓDIGO CODE	DN	PN
01A61026015	15	10-16-25-40
01A61026020	20	10-16-25-40
01A61026025	25	10-16-25-40
01A61026032	32	10-16-25-40
01A61026040	40	10-16-25-40
01A40026050	50	25-40
01A40026065	65	25-40
01A40026080	80	25-40
01A40026100	100	25-40
01A40026125	125	25-40
01A40026150	150	25-40
01A40026200	200	40
01A40026250	250	40
01A40026300	300	40

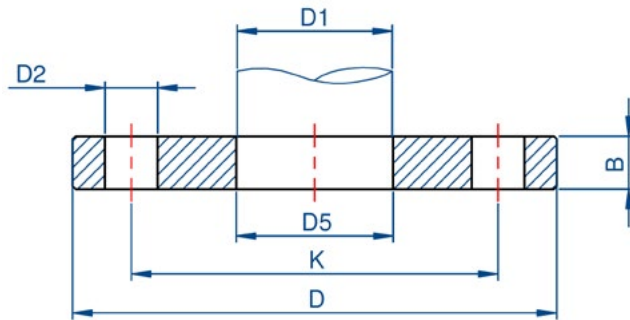

FICHA TÉCNICA
TECHNICAL SHEET

DN	PN	TUBO PIPE			BRIDA FLANGE			TORNILLOS BOLTS			PESO WEIGHT HT (7,85kg/m ³)
		TIPO TYPE	D1	D5	D	B	K	n°	ROSCA THREAD	D2	
15	10-16-25-40	ISO	21,3	22	95	14	65	4	M12	14	0,67
20	10-16-25-40	ISO	26,9	27,5	105	16	75	4	M12	14	0,94
25	10-16-25-40	ISO	33,7	34,5	115	16	85	4	M12	14	1,11
32	10-16-25-40	ISO	42,4	43,5	140	18	100	4	M16	18	1,82
40	10-16-25-40	ISO	48,3	49,5	150	18	110	4	M16	18	2,08
50	25-40	ISO	60,3	61,5	165	20	125	4	M16	18	2,73
65	25-40	ISO	76,1	77,5	185	22	145	8	M16	18	3,45
80	25-40	ISO	88,9	90,5	200	24	160	8	M16	18	4,32
100	25-40	ISO	114,3	116	235	26	190	8	M20	22	6,07
125	25-40	ISO	139,7	141,5	270	28	220	8	M24	26	8,19
150	25-40	ISO	168,3	170,5	300	30	250	8	M24	26	10,3
200	40	ISO	219,1	221,5	360	36	320	12	M27	30	17,9
250	40	ISO	273	276,5	425	42	385	12	M30	33	29,3
300	40	ISO	323,9	327,5	485	52	450	16	M30	33	45,1

BRIDA ROSCADA EN-1092-1 TIPO: 13B PN-16 THREADED PLATE FLANGE EN-1092-1 TYPE: 013B PN-16
BRIDA FORJADA DE ACERO INOXIDABLE STAINLESS STEEL FORGED FLANGE

13B PN16 BSP A304L

Brida roscada
Material: acero inoxidable
EN 1.4307 / A304L

Threaded flange EN-1092-1 Type: 013B
Material: stainless steel
EN 1.4404 / A304L



CÓDIGO CODE	DN	PN	ROSCA THREAD
13B61054015	15	10-16-25-40	1/2"
13B61054020	20	10-16-25-40	3/4"
13B61054025	25	10-16-25-40	1"
13B61054032	32	10-16-25-40	1 1/4"
13B61054040	40	10-16-25-40	1 1/2"
13B61054050	50	10-16	2"
13B61054065	65	10-16	2 1/2"
13B61054080	80	10-16	3"
13B61054100	100	10-16	4"

13B PN16 BSP A316L

Brida roscada
Material: acero inoxidable
EN 1.4404 / A316L

Threaded flange EN-1092-1 Type: 013B
Material: stainless steel
EN 1.4404 / A316L



CÓDIGO CODE	DN	PN	ROSCA THREAD
13B61056015	15	10-16-25-40	1/2"
13B61056020	20	10-16-25-40	3/4"
13B61056025	25	10-16-25-40	1"
13B61056032	32	10-16-25-40	1 1/4"
13B61056040	40	10-16-25-40	1 1/2"
13B61056050	50	10-16	2"
13B61056065	65	10-16	2 1/2"
13B61056080	80	10-16	3"
13B61056100	100	10-16	4"

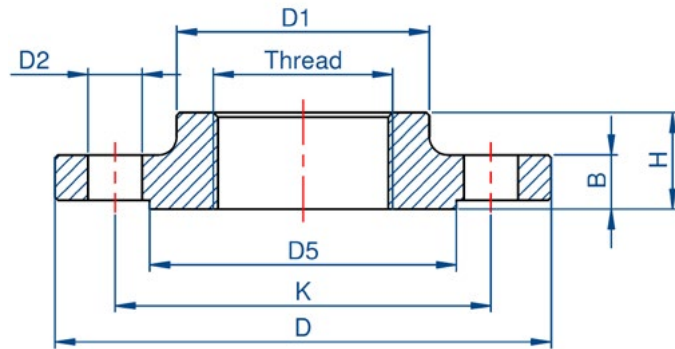

FICHA TÉCNICA
TECHNICAL SHEET

DN	PN	ROSCA THREAD	BRIDA FLANGE						TORNILLOS BOLTS			PESO WEIGHT HT (7,85kg/m3)
			D	D5	H	K	D1	B	nº	ROSCA THREAD	D2	
15	10-16-25-40	1/2"	95	45	22	65	35	16	4	M12	14	0,72
20	10-16-25-40	3/4"	105	58	26	75	45	18	4	M12	14	1,04
25	10-16-25-40	1"	115	68	28	85	52	18	4	M12	14	1,25
32	10-16-25-40	1 1/4"	140	78	30	100	60	18	4	M16	18	1,81
40	10-16-25-40	1 1/2"	150	88	32	110	70	18	4	M16	18	2,06
50	10-16	2"	165	102	28	125	84	18	4	M16	18	2,39
65	10-16	2 1/2"	185	122	32	145	104	18	8 (4)	M16	18	2,97
80	10-16	3"	200	138	34	160	118	20	8	M16	18	3,78
100	10-16	4"	220	158	40	180	140	20	8	M16	18	4,38

BRIDA CIEGA EN-1092-1 TIPO: 05A PN-10 BLIND FLANGE EN-1092-1 TYPE: 05A PN-10
BRIDA FORJADA DE ACERO INOXIDABLE STAINLESS STEEL FORGED FLANGE

05A PN10 A304L

Brida ciega
Material: acero inoxidable EN 1.4307 / A304L
Blind flange EN-1092-1 Type: 05A
Material: stainless steel EN 1.4307 / A304L



CÓDIGO CODE	DN	PN
05A61044015	15	10-16-25-40
05A61044020	20	10-16-25-40
05A61044025	25	10-16-25-40
05A61044032	32	10-16-25-40
05A61044040	40	10-16-25-40
05A61044050	50	10-16
05A61044065	65	10-16
05A61044080	80	10-16
05A61044100	100	10-16
05A61044125	125	10-16
05A61044150	150	10-16
05A10044200	200	10
05A10044250	250	10
05A10044300	300	10
05A10044350	350	10
05A10044400	400	10
05A10044450	450	10
05A10044500	500	10
05A10044600	600	10
05A10044700	700	10
05A10044800	800	10
05A10044900	900	10
05A10044000	1000	10

05A PN10 A316L

Brida ciega
Material: acero inoxidable EN 1.4404 / A316L
Blind flange EN-1092-1 Type: 05A
Material: stainless steel EN 1.4404 / A316L



CÓDIGO CODE	DN	PN
05A61046015	15	10-16-25-40
05A61046020	20	10-16-25-40
05A61046025	25	10-16-25-40
05A61046032	32	10-16-25-40
05A61046040	40	10-16-25-40
05A61046050	50	10-16
05A61046065	65	10-16
05A61046080	80	10-16
05A61046100	100	10-16
05A61046125	125	10-16
05A61046150	150	10-16
05A10046200	200	10
05A10046250	250	10
05A10046300	300	10
05A10046350	350	10
05A10046400	400	10
05A10046450	450	10
05A10046500	500	10
05A10046600	600	10
05A10046700	700	10
05A10046800	800	10
05A10046900	900	10
05A10046000	1000	10

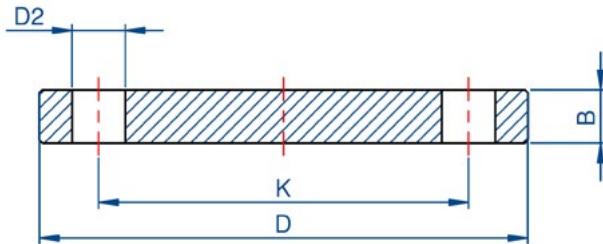

FICHA TÉCNICA
TECHNICAL SHEET

DN	PN	BRIDA FLANGE			TORNILLOS BOLTS			PESO WEIGHT HT (7,85kg/m ³)
		D	B	ØK	nº	ROSCA THREAD	D2	
15	10-16-25-40	95	16 (14)	65	4	M12	14	0,813 (0,72)
20	10-16-25-40	105	18 (16)	75	4	M12	14	1,14 (1,01)
25	10-16-25-40	115	18 (16)	85	4	M12	14	1,38 (1,23)
32	10-16-25-40	140	18 (16)	100	4	M16	18	2,03 (1,8)
40	10-16-25-40	150	18 (16)	110	4	M16	18	2,35 (2,09)
50	10-16	165	18	125	4	M16	18	2,88
65	10-16	185	18	145	8	M16	18	3,51 (3,66)
80	10-16	200	20	160	8	M16	18	4,61 (4,77)
100	10-16	220	20	180	8	M16	18	5,65
125	10-16	250	22	210	8	M16	18	8,13 (8,42)
150	10-16	285	22	240	8	M20	22	10,5 (10,4)
200	10	340	24	295	8	M20	22	16,5
250	10	395	26	350	12	M20	22	24,1 (24)
300	10	445	26	400	12	M20	22	30,8 (30,9)
350	10	505	26	460	16	M20	22	39,6 (40,6)
400	10	565	26	515	16	M24	26	49,4
450	10	615	28	565	20	M24	26	63
500	10	670	28	620	20	M24	26	75,2 (75)
600	10	780	34 (30)	725	20	M27	30	124,00
700	10	895	38 (32)	840	24	M27	30	183,00
800	10	1015	48 (36)	950	24	M30	33	297,00
900	10	1115	50	1050	28	M30	33	374,00
1000	10	1230	54	1160	28	M33	36	492,00

• Valores entre paréntesis pertenecen a la DIN 2527
Values in parentheses belong to DIN 2527

BRIDA CIEGA EN-1092-1 TIPO: 05A PN-16 BLIND FLANGE EN-1092-1 TYPE: 05A PN-16
BRIDA FORJADA DE ACERO INOXIDABLE STAINLESS STEEL FORGED FLANGE

05A PN16 A316L

Brida ciega

Material: acero inoxidable EN 1.4404 / A316L

Blind flange EN-1092-1 Type: 05A

Material: stainless steel EN 1.4404 / A316L



CÓDIGO CODE	DN	PN
05A16046200	200	16
05A16046250	250	16
05A16046300	300	16
05A16046350	350	16
05A16046400	400	16
05A16046450	450	16
05A16046500	500	16
05A16046600	600	16
05A16046700	700	16
05A16046800	800	16

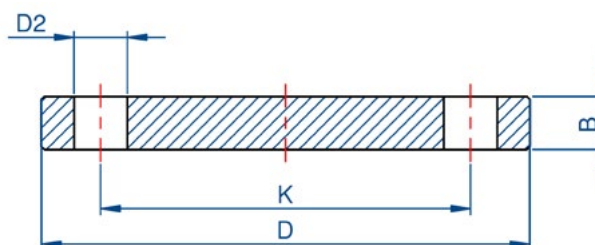

FICHA TÉCNICA
TECHNICAL SHEET

DN	PN	D	BRIDA FLANGE		nº	TORNILLOS BOLTS		PESO WEIGHT HT (7,85kg/m3)
			b	k		ROSCA THREAD	D2	
200	16	340	24	295	12	M20	22	16,2
250	16	405	26	355	12	M24	26	25
300	16	460	28	410	12	M24	26	35,1
350	16	520	30	470	16	M24	26	48
400	16	580	32	525	16	M27	30	63,5
450	16	640	42	585	20	M27	30	96,6
500	16	715	44 (36)	650	20	M30	33	133
600	16	840	54	770	20	M33	36	226
700	16	910	58	840	24	M33	36	285
800	16	1025	62	950	24	M33	39	388

- Valores entre paréntesis pertenecen a la DIN 2527
Values in parentheses belong to DIN 2527

BRIDA CON CUELLO EN-1092-1 TIPO: 11B PN-16 WELDING NECK FLANGE EN-1092-1 TYPE: 11B PN-16
 BRIDA FORJADA DE ACERO INOXIDABLE STAINLESS STEEL FORGED FLANGE

11B PN16 A304L

 Brida con cuello
 Material: acero inoxidable EN 1.4307 / A304L
 Welding neck flange EN-1092-1 Type: 11B
 Material: stainless steel EN 1.4307 / A304L

CÓDIGO CODE	DN	PN
11B161024015	15	10-16-25-40
11B161024020	20	10-16-25-40
11B161024025	25	10-16-25-40
11B161024032	32	10-16-25-40
11B161024040	40	10-16-25-40
11B161024050	50	10-16
11B161024065	65	10-16
11B161024080	80	10-16
11B161024100	100	10-16
11B161024125	125	10-16
11B161024150	150	10-16
11B116024200	200	16
11B116024250	250	16
11B116024300	300	16
11B116024350	350	16
11B116024400	400	16
11B116024500	500	16

- Para tubo ISO
ISO pipes

11B PN16 A316L

 Brida con cuello
 Material: acero inoxidable EN 1.4404 / A316L
 Welding neck flange EN-1092-1 Type: 11B
 Material: stainless steel EN 1.4404 / A316L

CÓDIGO CODE	DN	PN
11B161026015	15	10-16-25-40
11B161026020	20	10-16-25-40
11B161026025	25	10-16-25-40
11B161026032	32	10-16-25-40
11B161026040	40	10-16-25-40
11B161026050	50	10-16
11B161026065	65	10-16
11B161026080	80	10-16
11B161026100	100	10-16
11B161026125	125	10-16
11B161026150	150	10-16
11B116026200	200	16
11B116026250	250	16
11B116026300	300	16
11B116026350	350	16
11B116026400	400	16
11B116026500	500	16

- Para tubo ISO
ISO pipes

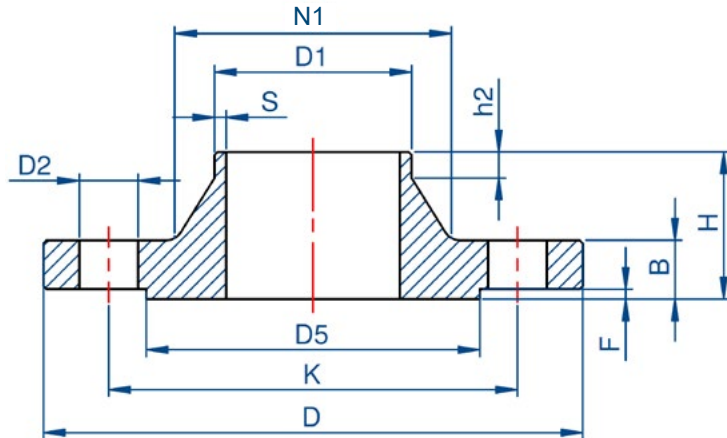
 FICHA TÉCNICA
 TECHNICAL SHEET

DN	PN	BRIDA FLANGE											TORNILLOS BOLTS		PESO WEIGHT HT (7,85kg/m3)
		D1	D3	D	B	K	H	S	h2	D5	F	n°	ROSCA THREAD	D2	
15	10-16-25-40	21,3	32	95	16	65	38	2	6	45	2	4	M12	14	0,77
20	10-16-25-40	26,9	40	105	18	75	40	2,3	6	58	2	4	M12	14	1,09
25	10-16-25-40	33,7	46	115	18	85	40	2,6	6	68	2	4	M12	14	1,3
32	10-16-25-40	42,4	56	140	18	100	42	2,6	6	78	2	4	M16	18	1,91
40	10-16-25-40	48,3	64	150	18	110	45	2,6	7	88	3	4	M16	18	2,15
50	10-16	60,3	74	165	18	125	45	2,9	8	102	3	4	M16	18	2,53
65	10-16	76,1	92	185	18	145	45	2,9	10	122	3	8(4)	M16	18	3,03
80	10-16	88,9	105	200	20	160	50	3,2	10	138	3	8	M16	18	3,92
100	10-16	114,3	131	220	20	180	52	3,6	12	158	3	8	M16	18	4,62
125	10-16	139,7	156	250	22	210	55	4	12	188	3	8	M16	18	6,3
150	10-16	168,3	184	285	22	240	55	4,5	12	212	3	8	M20	22	7,81
200	16	219,1	235	340	24	295	62	6,3(5,9)	16	268	3	12	M20	22	11,5
250	16	273	292	405	26	355	70	6,3	16	320	3	12	M24	26	16,7
300	16	323,9	344	460	28	410	78	7,1	16	378	4	12	M24	26	22,1
350	16	355,6	390	520	30	470	82	8	16	438	4	16	M24	26	32,8
400	16	406,4	445	580	32	525	85	8	16	490	4	16	M27	30	41,1
500	16	508	548	715	36	650	84	8	16	610	4	20	M30	33	66,2

- Valores entre paréntesis pertenecen a la DIN 2633
Values in parentheses belong to DIN 2633

BRIDA CON CUELLO EN-1092-1 TIPO: 11B PN-40 WELDING NECK FLANGE EN-1092-1 TYPE: 11B PN-40
BRIDA FORJADA DE ACERO INOXIDABLE STAINLESS STEEL FORGED FLANGE

11B PN40 A304L

Brida con cuello

Material: acero inoxidable EN 1.4307 / A304L

Welding neck flange EN-1092-1 Type: 11B

Material: stainless steel EN 1.4307 / A304L

NEW



CÓDIGO CODE	DN	PN
11B161024015	15	10-16-25-40
11B161024020	20	10-16-25-40
11B161024025	25	10-16-25-40
11B161024032	32	10-16-25-40
11B161024040	40	10-16-25-40
11B40024050	50	25-40
11B40024065	65	25-40
11B40024080	80	25-40
11B40024100	100	25-40
11B40024125	125	25-40
11B40024150	150	25-40
11B40024200	200	40
11B40024250	250	40
11B40024300	300	40

- Para tubo ISO
ISO pipes

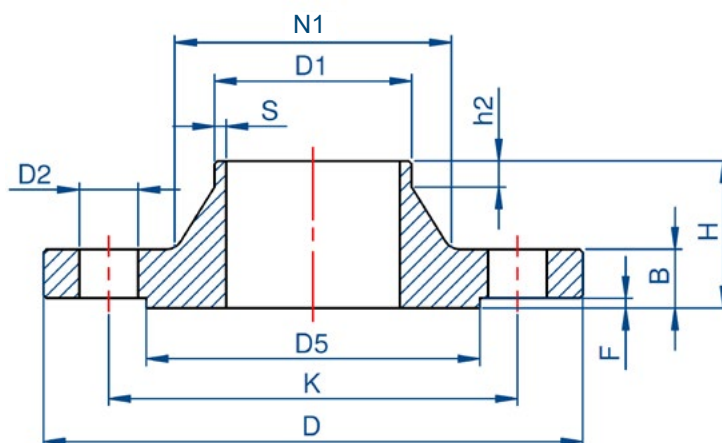

FICHA TÉCNICA
TECHNICAL SHEET

DN	PN	BRIDA FLANGE										TORNILLOS BOLTS			PESO WEIGHT HT (7,85kg/m3)
		D1	D3	D	B	K	H	S	h2	D5	F	nº	ROSCA THREAD	D2	
15	10-16-25-40	21,3	32	95	16	65	38	2	6	45	2	4	M12	14	0,77
20	10-16-25-40	26,9	40	105	18	75	40	2,3	6	58	2	4	M12	14	1,09
25	10-16-25-40	33,7	46	115	18	85	40	2,6	6	68	2	4	M12	14	1,3
32	10-16-25-40	42,4	56	140	18	100	42	2,6	6	78	2	4	M16	18	1,91
40	10-16-25-40	48,3	64	150	18	110	45	2,6	7	88	3	4	M16	18	2,15
50	25-40	60,3	75	165	18	125	48	2,9	8	102	3	4	M16	18	2,85
65	25-40	76,1	90	185	18	145	52	2,9	10	122	3	8	M16	18	3,68
80	25-40	88,9	105	200	20	160	58	3,2	10	138	3	8	M16	18	4,78
100	25-40	114,3	134	235	20	190	65	3,6	12	158	3	8	M20	22	6,46
125	25-40	139,7	162	270	22	220	68	4	12	188	3	8	M24	26	8,86
150	25-40	168,3	192	300	22	250	75	4,5	12	212	3	8	M24	26	11,7
200	40	219,1	244	375	24	320	88	6,3	16	268	3	12	M27	30	21
250	40	273	306	450	26	385	105	7,1	18	320	3	12	M30	33	34,2
300	40	323,9	362	515	28	450	115	8	18	378	4	16	M30	33	47,6

VALONA PARA BRIDA DIN/EN-1092 FOR DIN/EN-1092 FLANGE COLLARS
VALONA FORJADA DE ACERO INOXIDABLE STAINLESS STEEL FORGET SHORT NECK PRESSED

S525604

Valona ISO A-304L
Short neck pressed collars ISO A-304L



CÓDIGO CODE	MEDIDA SIZE	☐	☐
S525604015	21.3/2	1	1
S525604020	26.9/2	1	1
S525604025	33.7/2	1	1
S525604032	42.4/2	1	1
S525604040	48.3/2	1	1
S525604050	60.3/2	1	1
S525604065	76.1/2	1	1
S525604080	88.9/2	1	1
S525604100	114.3/2	1	1
S525604125	139.7/2	1	1
S525604150	168.3/2	1	1
S525604200	219.1/2	1	1
S525604250	273.1/2	1	1
S525604300	323.9/2	1	1

S525606

Valona ISO A-316L
Short neck pressed collars ISO A-316L



CÓDIGO CODE	MEDIDA SIZE	☐	☐
S525606015	21.3/2	1	1
S525606020	26.9/2	1	1
S525606025	33.7/2	1	1
S525606032	42.4/2	1	1
S525606040	48.3/2	1	1
S525606050	60.3/2	1	1
S525606065	76.1/2	1	1
S525606080	88.9/2	1	1
S525606100	114.3/2	1	1
S525606125	139.7/2	1	1
S525606150	168.3/2	1	1
S525606200	219.1/2	1	1
S525606250	273.1/2	1	1
S525606300	323.9/2	1	1



FICHA TÉCNICA
TECHNICAL SHEET

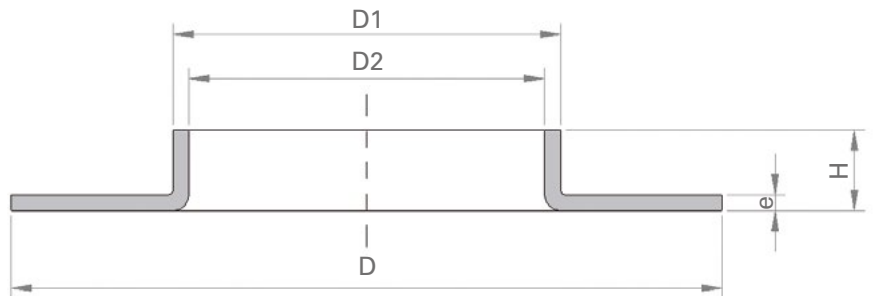

DN	DT	e	H	D	D1	D2
15	1/2"	2	6	43	21,3	17,3
20	3/4"	2	8	58	26,9	22,9
25	1"	2	9	68	33,7	29,7
32	1 1/4"	2	10	78	42,4	38,4
40	1 1/2"	2	10	88	48,3	44,3
50	2"	2	12	102	60,3	56,3
65	2 1/2"	2	12	122	76,1	72,1
80	3"	2	12	139	88,9	84,9
100	4"	2	16	158	114,3	110,3
125	5"	2	16	185	139,7	135,7
150	6"	2	17	212	168,3	164,3
200	8"	2	18	270	219,1	215,1
250	10"	2	18	323	273,0	269,0
300	12"	2	19	372	323,9	319,9

BRIDAS ANSI ANSI FLANGES

SO1506 ANSI 150
EN 1.4404/A-316L

Brida Slip-On A-316L
Slip On flange A-316L



CÓDIGO CODE	DN	PSI
SO1506-015	1/2"	150
SO1506-020	3/4"	150
SO1506-025	1"	150
SO1506-032	1 1/4"	150
SO1506-040	1 1/2"	150
SO1506-050	2"	150
SO1506-065	2 1/2"	150
SO1506-080	3"	150
SO1506-100	4"	150
SO1506-125	5"	150
SO1506-150	6"	150
SO1506-200	8"	150
SO1506-250	10"	150

WN1506 ANSI 150
EN 1.4404/A-316L

Brida welding neck A-316L
Welding neck flange A-316L



CÓDIGO CODE	DN	PSI
WN1506-015	1/2"	150
WN1506-020	3/4"	150
WN1506-025	1"	150
WN1506-032	1 1/4"	150
WN1506-040	1 1/2"	150
WN1506-050	2"	150
WN1506-065	2 1/2"	150
WN1506-080	3"	150
WN1506-100	4"	150
WN1506-125	5"	150
WN1506-150	6"	150
WN1506-200	8"	150
WN1506-250	10"	150

BL1506 ANSI 150
EN 1.4404/A-316L

Brida ciega A-316L
Blind flange A-316L



CÓDIGO CODE	DN	PSI
BL1506-015	1/2"	150
BL1506-020	3/4"	150
BL1506-025	1"	150
BL1506-032	1 1/4"	150
BL1506-040	1 1/2"	150
BL1506-050	2"	150
BL1506-065	2 1/2"	150
BL1506-080	3"	150
BL1506-100	4"	150
BL1506-125	5"	150
BL1506-150	6"	150
BL1506-200	8"	150
BL1506-250	10"	150

LJ1506 ANSI 150
EN 1.4404/A-316L

Brida Lap Joint A-316L
Lap Joint Flange A-316L



CÓDIGO CODE	DN	PSI
LJ1506-015	1/2"	150
LJ1506-020	3/4"	150
LJ1506-025	1"	150
LJ1506-032	1 1/4"	150
LJ1506-040	1 1/2"	150
LJ1506-050	2"	150
LJ1506-065	2 1/2"	150
LJ1506-080	3"	150
LJ1506-100	4"	150
LJ1506-125	5"	150
LJ1506-150	6"	150
LJ1506-200	8"	150
LJ1506-250	10"	150

SW1506 ANSI 150
EN 1.4404/A-316L

Brida socket welding
A-316L
Socket Welding flange
A-316L



CÓDIGO CODE	DN	PSI
SW1506-015	1/2"	150
SW1506-020	3/4"	150
SW1506-025	1"	150
SW1506-032	1 1/4"	150
SW1506-040	1 1/2"	150
SW1506-050	2"	150
SW1506-065	2 1/2"	150
SW1506-080	3"	150
SW1506-100	4"	150
SW1506-125	5"	150
SW1506-150	6"	150
SW1506-200	8"	150
SW1506-250	10"	150

FICHA TÉCNICA BRIDA ANSI 150 B 16.5 TECHNICAL DATA SHEET ANSI FLANGE 150 B 16.5

BRIDA FLANGE
ANSI BL

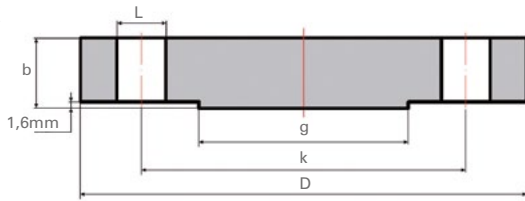

BRIDA FLANGE
ANSI LJ

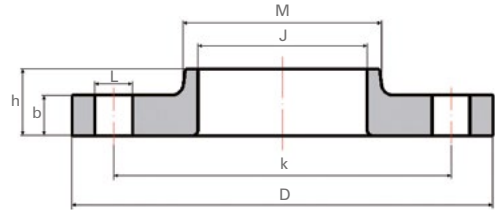

BRIDA FLANGE
ANSI SO

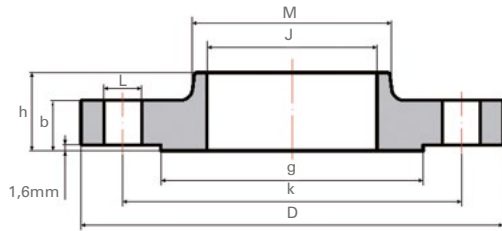

BRIDA FLANGE
ANSI SW

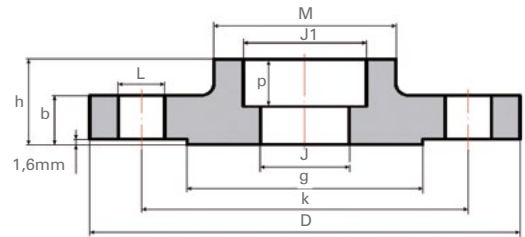

BRIDA FLANGE
ANSI WN

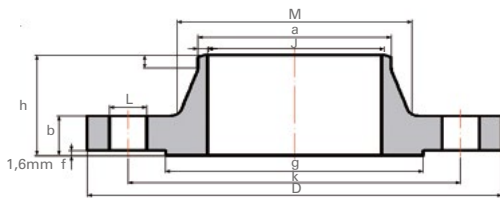

DN	BRIDA FLANGE					TORNILLOS BOLTS		
	D	b	M	g	k	N	ROSCA THREAD	L
1/2	90	11,2	30,2	35,1	60,5	4	1/2	15,7
3/4	100	12,7	38,1	42,9	69,9	4	1/2	15,7
1	110	14,2	49,3	50,8	79,2	4	1/2	15,7
1 1/4	118	15,7	58,7	63,5	88,9	4	1/2	15,7
1 1/2	125	17,5	65	73,2	98,6	4	1/2	15,7
2	150	19,1	77,7	91,9	120,7	4	5/8	19,1
2 1/2	180	22,4	90,4	104,6	139,7	4	5/8	19,1
3	190	23,9	108	127	152,4	4	5/8	19,1
4	230	23,9	134,9	157,2	190,5	8	5/8	19,1
5	254	23,9	163,6	185,7	215,9	8	3/4	22,4
6	280	25,4	192	215,9	241,3	8	3/4	22,4
8	345	28,4	246,1	269,7	298,5	8	3/3	22,4
10	405	30,2	304,8	323,8	361,9	12	7/8	25,4



FICHA TÉCNICA
TECHNICAL SHEET

DN	BLIND Kg	LAP JOINT			SLIP ON			SOCKET WELDING				WELDING NECK				
		J	h	Kg	J	h	Kg	J	J1	p	h	Kg	J	h	a	Kg
1/2	0,4	22,9	15,7	0,4	22,4	15,7	0,4	22,4	15,7	9,6	15,7	0,4	15,7	47,8	21,3	0,5
3/4	0,7	28,2	15,7	0,7	27,7	15,7	0,7	27,7	20,8	11,1	15,7	0,7	20,8	52,3	26,7	0,7
1	0,9	35,1	17,5	0,8	34,5	17,5	0,8	34,5	26,7	12,7	17,5	0,9	26,7	55,6	33,5	1,1
1 1/4	1,3	43,7	20,6	1,1	43,2	20,6	1,1	43,2	35,1	14,2	20,6	1,2	35,1	57,2	42,2	1,5
1 1/2	1,6	50	22,4	1,4	49,5	22,4	1,4	49,5	40,9	15,7	22,4	1,5	40,9	62	48,3	1,8
2	2,6	62,5	25,4	2,2	62	25,4	2,2	62	52,6	17,5	25,4	2,3	52,6	63,5	60,5	2,7
2 1/2	4,1	75,4	28,4	3,6	74,7	28,4	3,6	74,7	62,7	19	28,4	3,7	62,7	69,9	73,2	4,4
3	5	91,4	30,2	4,1	90,7	30,2	4,1	90,7	78	20,6	30,2	4,2	78	69,9	88,9	5,2
4	7,1	116,8	33,3	5,6	116,1	33,3	5,6	116,1	102,4	23,9	33,3	5,8	102,4	76,2	114,3	7,5
5	9	144,5	36,6	6,3	143,8	36,6	6,3	143,8	128,3	23,9	36,6	6,5	128,3	88,9	141,2	9,2
6	11,8	171,5	39,6	7,5	170,7	39,6	7,5	170,7	154,2	26,9	39,6	7,8	154,2	88,9	168,4	11
8	21	222,3	44,5	12,6	221,5	44,5	12,6	221,5	202,7	31,8	44,5	13,1	202,7	101,6	219,2	18,3
10	31,8	277,4	49,9	19,5	276,3	49,9	19,5	276,4	254,5	33,3	49,9	20,1	254,4	101,6	273	23

BRIDA PRENSADA **2642** PRESSED FLANGED **2642**
VALONA FORJADA DE ACERO INOXIDABLE STAINLESS STEEL FORGET SHORT NECK PRESSED

2642024 ISO A-304L

Brida prensada DIN-2642
ISO A-304L

Pressed flanged din 2642
ISO A-304L



CÓDIGO CODE	MEDIDA SIZE	☐	☐
2642024015	1/2"	1	1
2642024020	3/4"	1	1
2642024025	1"	1	1
2642024032	1 1/4"	1	1
2642024040	1 1/2"	1	1
2642024050	2"	1	1
2642024065	2 1/2"	1	1
2642024080	3"	1	1
2642024100	4"	1	1
2642024125	5"	1	1
2642024150	6"	1	1
2642024200	8"	1	1
2642024250	10"	1	1
2642024300	12"	1	1

2642026 ISO A-316L

Brida prensada DIN-2642
ISO A-316L

Pressed flanged din 2642
ISO A-316L



CÓDIGO CODE	MEDIDA SIZE	☐	☐
2642026015	1/2"	1	1
2642026020	3/4"	1	1
2642026025	1"	1	1
2642026032	1 1/4"	1	1
2642026040	1 1/2"	1	1
2642026050	2"	1	1
2642026065	2 1/2"	1	1
2642026080	3"	1	1
2642026100	4"	1	1
2642026125	5"	1	1
2642026150	6"	1	1
2642026200	8"	1	1
2642026250	10"	1	1
2642026300	12"	1	1



FICHA TÉCNICA
TECHNICAL SHEET

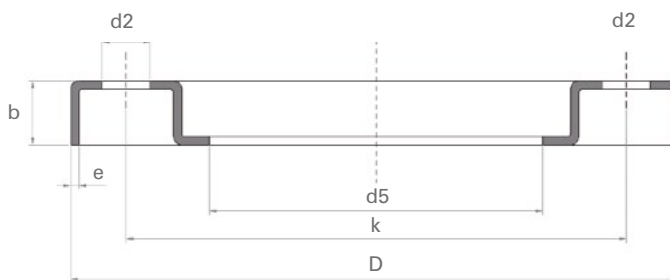

DN	MEDIDA SIZE	PN	TUBO PIPE	d5	D	b	k	e	N	ROSCA THREAD	d2	PESO WEIGHT
15	1/2"	10-16	21,3	25	95	11,5	65	3	4	M12	13,5	0,19
20	3/4"	10-16	26,9	31	105	14	75	3	4	M12	13,5	0,26
25	1"	10-16	33,7	38	115	16	85	3	4	M12	13,5	0,32
32	1 1/4"	10-16	42,4	47	140	16,5	100	3	4	M16	17,5	0,46
40	1 1/2"	10-16	48,3	53	150	17,5	110	3	4	M16	17,5	0,49
50	2"	10-16	60,3	66	165	19,5	125	3	4	M16	17,5	0,60
65	2 1/2"	10-16	76,1	82	185	21	145	3	4	M16	17,5	0,76
80	3"	10-16	88,9	95	200	22	160	3	8	M16	17,5	0,81
100	4"	10-16	114,3	120	220	23	180	4	8	M16	17,5	1,19
125	5"	10-16	139,7	146	250	25	210	4	8	M16	17,5	1,47
150	6"	10-16	168,3	175	295	27	240	5	8	M20	21,5	2,35
200	8"	10	219,1	227	340	31	295	6	8	M20	21,5	3,60
250	10"	10	273	281	395	34	350	6	8	M20	21,5	4,58
300	12"	10	323,9	331	445	38	400	6	8	M20	21,5	5,59

3

AUTOMATIZACIÓN DE VÁLVULAS

VALVES AUTOMATION



SERVICIO INTEGRAL DE MONTAJE Y ENTREGA INMEDIATA EN 24 HORAS



En MT no nos gustan las sorpresas y los problemas derivados de un mal montaje de nuestros productos. Es por este motivo, que disponemos de personal técnico especializado para adaptar el automatismo correcto en cada una de nuestras válvulas y las probamos antes de mandar al cliente. Con ello garantizamos un correcto funcionamiento de nuestras válvulas actuadas y ofrecemos un servicio rápido de montaje y entrega en un tiempo récord. MT, buscando siempre la mejor solución para nuestro cliente.

INTEGRAL ASSEMBLY SERVICE AND IMMEDIATE DELIVERY IN 24 HOURS

In MT we don't like the surprises and the problems derived from a bad assembly of our products. For this reason, we have specialized technical personnel to adapt the correct automation in each of our valves and test them before sending the customer. With this we guarantee the correct functioning of our actuated valves and we offer a fast service of assembly and delivery in a record time. MT, always looking for the best solution for our client.

Rango de temperatura °C
Temperature range °C



Presión máxima de trabajo en Bar
Maximum working pressure Bar



Cuerpo en fundición nodular GGG-40 con recubrimiento pintura Epoxi RAL5013
Ductile Iron body GGG-40 with Epoxy coating paint RAL5013

Producto 5105140

Válvula de mariposa tipo wafer EPDM disco poliamida 11 con actuador

Product 5105140

Butterfly valve wafer type stainless steel disc EPDM hard seat with actuator



DATOS TÉCNICOS TECHNICAL DATA SHEET

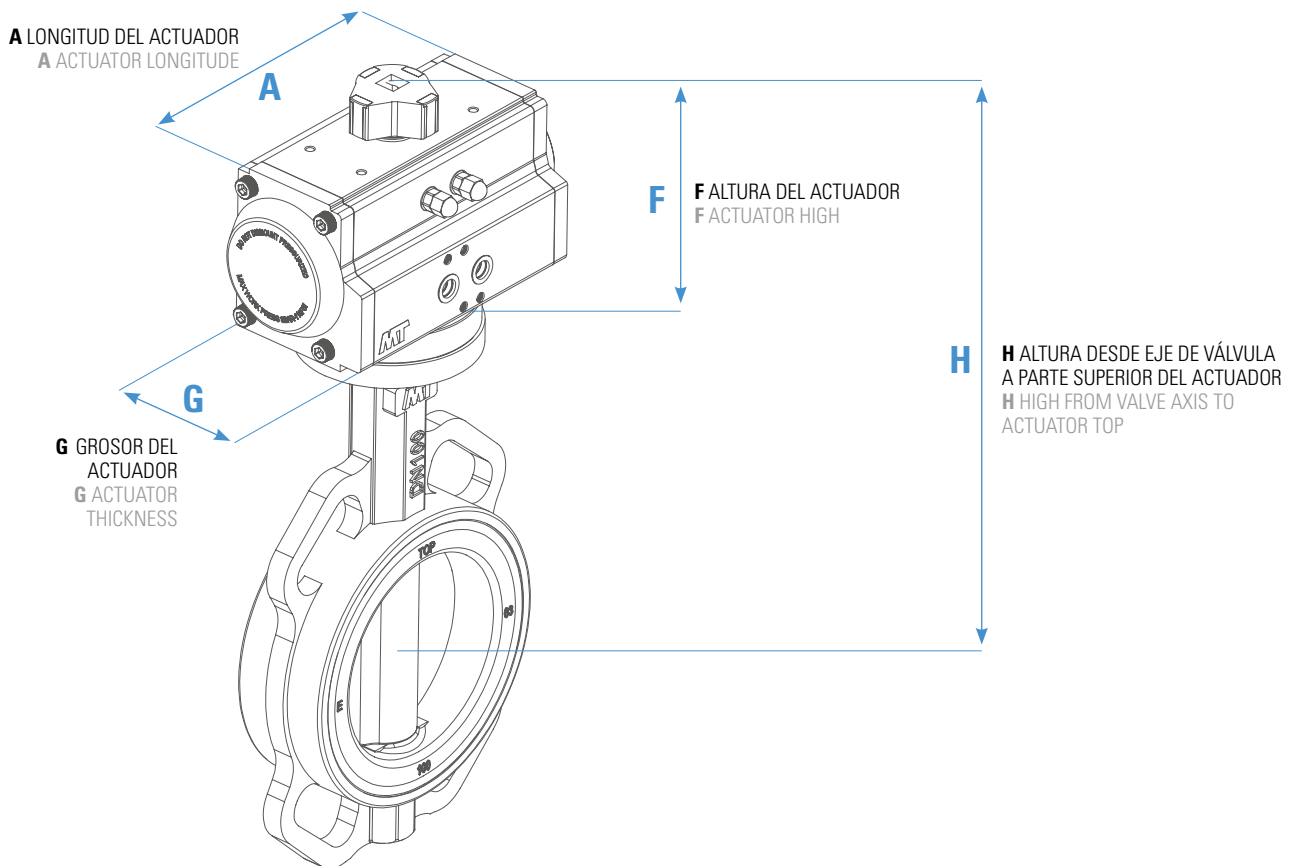

ACTUADORES NEUMÁTICOS PNEUMATIC ACTUATORS

5100



Actuador neumático simple efecto

Pneumatic simple return actuator

FICHA TÉCNICA
TECHNICAL SHEET

CÓDIGO CODE	6 BAR	8 BAR	Muelle Final Final Doc	ISO 5211	s
5100-052	12,5	21	9,5	F03-F05	11
5100-063	21	36	16,3	F05-F07	11
5100-075	37,1	61,8	24,4	F05-F07	14
5100-083	45,7	78,2	35,6	F05-F07	17
5100-092	66,9	113,5	52,3	F05-F07	17
5100-105	97,2	166,5	94,3	F07-F10	17
5100-125	177	299	127	F07-F10	22
5100-140	220	405	222	F10-F12	27
5100-160	338	619	343	F10-F12	27
5100-190	524	978	557	F14	27
5100-210	750	1373	713	F14	36
5100-240	1018	1995	1075	F16	36
5100-270	1633	3007	1295	F16	46

5200



Actuador neumático doble efecto

Pneumatic double acting actuator

FICHA TÉCNICA
TECHNICAL SHEET

CÓDIGO CODE	6 BAR	8 BAR	ISO 5211	s
5200-052	25,5	34	F03-F05	11
5200-063	44,9	59,9	F05-F07	11
5200-075	74,2	99	F05-F07	14
5200-083	97,4	130	F05-F07	17
5200-092	140	186	F05-F07	17
5200-105	207,8	227	F07-F10	17
5200-125	368	490,8	F07-F10	22
5200-140	554	739	F10-F12	27
5200-160	844	1126	F10-F12	27
5200-190	1361	1814	F14	27
5200-210	1870	2493	F14	36
5200-240	2931	3908	F16	36
5200-270	4122	5496	F16	46

540052



Electroválvulas normativa
namur 5/2 vías

Series namur type 5/2
ways solenoid valve



FICHA TÉCNICA
TECHNICAL SHEET

CÓDIGO CODE	VOLTAJE VOLTAGE
540052-01	DC24V
540052-02	AC24V-DC12V
540052-03	AC110V
540052-04	AC220V

- Utilizada para actuadores doble efecto, salvo excepciones.
Doble acting actuators used, with exceptions.

540032



Electroválvulas normativa
namur 3/2 vías

Series namur type 3/2
ways solenoid valve



FICHA TÉCNICA
TECHNICAL SHEET

CÓDIGO CODE	VOLTAJE VOLTAGE
540032-01	DC24V
540032-02	AC24V-DC12V
540032-03	AC110V
540032-04	AC220V

- Utilizada para actuadores simple efecto, salvo excepciones.
Spring return actuators used, with exceptions.

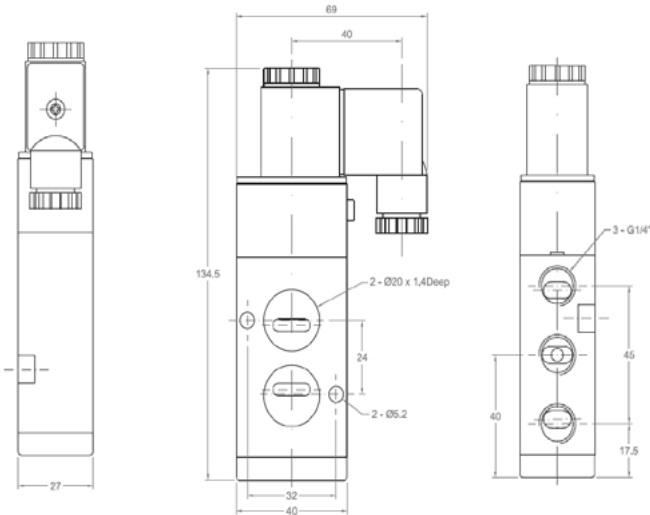

CÓDIGO CODE	ESQUEMA DIAGRAM	MATERIAL CUERPO BODY MATERIAL	MATERIAL JUNTA SEALS MATERIAL
540052		Aluminio anodizado Anonized aluminium	NBR
540032		Aluminio anodizado Anonized aluminium	NBR

CÓDIGO CODE	NÚMERO POSICIÓN POSITION NUMBER	VOLTAJE BOBINA COLL VOLTAGE	TAMAÑO PUERTO PORT SIZE	CONECTOR DISPONIBLE AVAILABLE CONNECTOR	CONSUMO POWER CONSUMPTION
540052	5 Position 2 way	DC12V DC24V AC24V	1/4"	With led	AC 4.5VA DC: 3W
540032	3 Position 2 ways	DC110V AC110V AC220V	1/4"	-	AC 4.5VA DC: 3W

51SMC



Posicionador para actuador
neumático 4/20mA-0/10V

Pneumatic electric actuator
positioner 4/20mA-0/10V



FICHA TÉCNICA
TECHNICAL SHEET

CÓDIGO CODE
51SMC

- Especificar el tipo de señal en el pedido 4-20mA o 0-10V
Specify signal input 4-20mA or 0-10V in the order

51CFC



Caja final de carrera

End microbox



FICHA TÉCNICA
TECHNICAL SHEET

CÓDIGO CODE
51CFC

- Caja polipropileno + 15% fibra de vidrio
Polypropilene + 15% fiber glass box
- Soporte acero + epoxi para condiciones ambientales extremas como opción en soporte inoxidable.
Steel + epoxy brackets stainless steel for extreme weather optional.
- Unión soporte Namur
Univeral Namur
- 2 micros mecánicos
2 mechanical switches

ACTUADORES ELÉCTRICOS ELECTRIC ACTUATORS

5300
5324

Actuador eléctrico		Electric actuator		
CÓDIGO CODE	PAR NM	VOLTAJE VOLTAGE	ISO 5211	s
5300-010 5324-010	10	85v-240v 24v	F03-F04-F05	14
5300-020 5324-020	20	24v-240v 12v	F03-F04-F05	14
5300-035 5324-035	35	24v-240v 12v	F03-F04-F05	14
5300-055 5324-055	55	24v-240v 12v	F05-F07	17
5300-085 5324-085	85	24v-240v 12v	F05-F07	17
5300-140 5324-140	140	24v-240v 12v	F07-F10	22
5300-300 5324-300	300	24v-240v 12v	F07-F10	22

CÓDIGO CODE	VOLTAJE VOLTAGE
5300-010	85v-240v VAC/VDC
5300-020	24v-240v VAC/VDC
5300-035	24v-240v VAC/VDC
5300-055	24v-240v VAC/VDC
5300-085	24v-240v VAC/VDC
5300-140	24v-240v VAC/VDC
5300-300	24v-240v VAC/VDC
5324-010	24v VAC/VDC
5324-020	12v VAC/VDC
5324-035	12v VAC/VDC
5324-055	12v VAC/VDC
5324-085	12v VAC/VDC
5324-140	12v VAC/VDC
5324-300	12v VAC/VDC

 FICHA TÉCNICA
TECHNICAL SHEET

51DPS



Kit posicionador para actuador eléctrico
4/20mA-0/10V

Electric actuator positioner
kit 4/20mA-0/10V

 FICHA TÉCNICA
TECHNICAL SHEET

CÓDIGO CODE

51DPS01*

51DPS02**

- Especificar el tipo de señal en el pedido 4-20mA ó 0-10V
Specify signal input 4-20mA or 0-10V before order

* Para actuadores eléctricos 20/35/55/85

* For electric actuators 20/35/55/85

**Para actuadores eléctricos 140/300

**For electric actuators 140/300

51BSR



Kit bloque de seguridad para actuador eléctrico

Safety lock electric actuator kit

 FICHA TÉCNICA
TECHNICAL SHEET

CÓDIGO CODE

51BSR01*

51BSR02**

- El actuador gira a su posición predeterminada en caso de falta de tensión
Actuator goes to initial position in case no voltage

Actuator goes to initial position in case no voltage

* Para actuadores eléctricos 20/35/55/85

* For electric actuators 20/35/55/85

**Para actuadores eléctricos 140/300

**For electric actuators 140/300

DATOS TÉCNICOS ISO 5211 ISO 5211 DATA SHEET

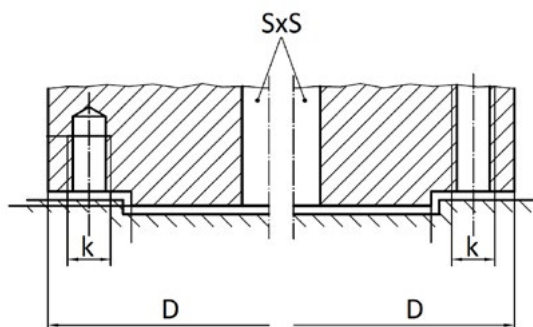

BRIDA FLANGE	PAR MÁX. N·m MAX. TORQUE N·m	D	D (K)	SXS	n
F03	32	46	M5	9	4
F04	63	54	M5	9 - 11	4
F05	125	65	M6	9 - 14	4
F07	250	90	M8	11 - 17	4
F10	500	125	M10	14 - 22	4
F12	1.000	150	M12	17 - 27	4
F14	2.000	175	M16	22 - 36	4
F16	4.000	210	M20	27 - 46	8
F25	8.000	300	M16	36 - 55	8
F30	16.000	350	M20	46 - 75	8
F35	32.000	415	M30	-	8
F40	63.000	475	M36	-	8
F48	125.000	560	M36	-	12
F60	250.000	686	M36	-	20

CÓDIGO CODE _____
 ACTUADOR ACTUATOR _____
H ALTURA DESDE EJE DE VÁLVULA A PARTE SUPERIOR DEL ACTUADOR
 HIGH FROM VALVE AXIS TO ACTUATOR TOP _____
F ALTURA DEL ACTUADOR ACTUATOR HIGH _____
A LONGITUD DEL ACTUADOR ACTUATOR LONGITUDE _____
G GROSOR DEL ACTUADOR ACTUATOR THICKNESS _____
 MEDIDA SIZE _____

5114
5105114
 SIMPLE EFECTO
 SIMPLE RETURN
 ACTUATOR



Válvula de mariposa tipo wafer disco inoxidable asiento blando EPDM con actuador
 Butterfly valve wafer type stainless steel disc EPDM soft seat with actuator



5105114-040	5100052	248	92	145	71	1 1/2"
5105114-050	5100075	276	120	201	94	2"
5105114-065	5100075	288	120	201	94	2 1/2"
5105114-080	5100083	304	128	209	101	3"
5105114-100	5100083	321	128	209	101	4"
5105114-125	5100125	383	175	332	138	5"
5105114-150	5100125	394	175	332	138	6"
5105114-200	5100160	484	217	450	174	8"
5105114-250	5100160	514	217	450	174	10"
5105114-300	5100190	627	260	507	206	12"

- Actuadores neumáticos ATEX. Para diámetros superiores consultar disponibilidad
 Pneumatic actuators ATEX. Larger diameters under request
- Los actuadores neumáticos están calculados en base a una presión de aire de entrada de 6 Bares
 Pneumatic actuators are calculated based on an inlet air pressure of 6 Bar

5114
5205114
 DOBLE EFECTO
 DOUBLE ACTING
 ACTUATOR



Válvula de mariposa tipo wafer disco inoxidable asiento blando EPDM con actuador
 Butterfly valve wafer type stainless steel disc EPDM soft seat with actuator



5205114-040	5200052	238	92	145	71	1 1/2"
5205114-050	5200052	248	92	145	71	2"
5205114-065	5200052	260	92	145	71	2 1/2"
5205114-080	5200063	284	108	169	82	3"
5205114-100	5200063	301	108	169	82	4"
5205114-125	5200083	336	128	209	101	5"
5205114-150	5200083	347	128	209	101	6"
5205114-200	5200105	420	153	275	122	8"
5205114-250	5200125	472	175	332	138	10"
5205114-300	5200140	559	192	385	153	12"

- Actuadores neumáticos ATEX. Para diámetros superiores consultar disponibilidad
 Pneumatic actuators ATEX. Larger diameters under request
- Los actuadores neumáticos están calculados en base a una presión de aire de entrada de 6 Bares
 Pneumatic actuators are calculated based on an inlet air pressure of 6 Bar

5114
5325114
 ACTUADOR ELÉCTRICO BAJO VOLTAJE
 ELECTRIC ACTUATOR LOW VOLTAGE



Válvula de mariposa tipo wafer disco inoxidable asiento blando EPDM con actuador
 Butterfly valve wafer type stainless steel disc EPDM soft seat with actuator

5325114-040	5324020	315	169	181	110	1 1/2"
5325114-050	5324020	325	169	181	110	2"
5325114-065	5324035	337	169	181	110	2 1/2"
5325114-080	5324055	345	169	181	110	3"
5325114-100	5324055	389	196	181	110	4"
5325114-125	5324085	404	196	181	128	5"
5325114-150	5324140	458	254	235	214	6"
5325114-200	5324300	521	254	235	214	8"
5325114-250	5324300	551	254	235	214	10"

- 12V VAC/VDC
- Para diámetros superiores consultar disponibilidad. Larger diameters under request

5114
5305114
 ACTUADOR ELÉCTRICO ALTO VOLTAJE
 ELECTRIC ACTUATOR HIGH VOLTAGE



Válvula de mariposa tipo wafer disco inoxidable asiento blando EPDM con actuador
 Butterfly valve wafer type stainless steel disc EPDM soft seat with actuator

5305114-040	5300020	315	169	181	110	1 1/2"
5305114-050	5300020	325	169	181	110	2"
5305114-065	5300035	337	169	181	110	2 1/2"
5305114-080	5300055	345	169	181	110	3"
5305114-100	5300055	389	196	181	110	4"
5305114-125	5300085	404	196	181	128	5"
5305114-150	5300140	458	254	235	214	6"
5305114-200	5300300	521	254	235	214	8"
5305114-250	5300300	551	254	235	214	10"

- 24V-240V VAC/VDC
- Para diámetros superiores consultar disponibilidad. Larger diameters under request

Para temperaturas superiores a 70°C se debe montar un puente separador entre la válvula y el actuador.
 At temperatures above 70°C separating bridge must be mounted between the valve and the actuator.

CÓDIGO CODE
 ACTUADOR ACTUATOR
H ALTURA DESDE EJE DE VÁLVULA A PARTE SUPERIOR DEL ACTUADOR
 HIGH FROM VALVE AXIS TO ACTUATOR TOP
F ALTURA DEL ACTUADOR ACTUATOR HIGH
A LONGITUD DEL ACTUADOR ACTUATOR LENGTH
G GROSOR DEL ACTUADOR ACTUATOR THICKNESS
 MEDIDA SIZE

5115
5105115
 SIMPLE EFECTO
 SIMPLE RETURN
 ACTUATOR



Válvula de mariposa tipo
 wafer disco cromado
 asiento rígido EPDM con
 actuador
 Butterfly valve wafer type
 chromed disc EPDM hard
 seat with actuator



5105115-050	5100063	249	108	169	82	2"
5105115-065	5100075	272	120	201	94	2 1/2"
5105115-080	5100092	300	140	242	109	3"
5105115-100	5100092	325	140	242	109	4"
5105115-125	5100105	353	153	275	122	5"
5105115-150	5100125	380	175	332	138	6"
5105115-200	5100140	447	192	385	153	8"
5105115-250	5100160	482	192	385	153	10"
5105115-300	5100190	590	260	507	206	12"

- Actuadores neumáticos ATEX. Para diámetros superiores consultar disponibilidad
Pneumatic actuators ATEX. Larger diameters under request
- Los actuadores neumáticos están calculados en base a una presión de aire de entrada de 6 Bares
Pneumatic actuators are calculated based on an inlet air pressure of 6 Bar

5115
5205115
 DOBLE EFECTO
 DOUBLE ACTING
 ACTUATOR



Válvula de mariposa tipo
 wafer disco cromado
 asiento rígido EPDM con
 actuador
 Butterfly valve wafer type
 chromed disc EPDM hard
 seat with actuator



5205115-050	5200052	233	92	145	71	2"
5205115-065	5200052	244	92	145	71	2 1/2"
5205115-080	5200063	268	108	169	82	3"
5205115-100	5200063	293	108	169	82	4"
5205115-125	5200075	320	120	201	94	5"
5205115-150	5200083	348	128	209	101	6"
5205115-200	5200105	408	153	275	122	8"
5205115-250	5200105	443	153	275	122	10"
5205115-300	5200125	505	175	332	138	12"

- Actuadores neumáticos ATEX. Para diámetros superiores consultar disponibilidad
Pneumatic actuators ATEX. Larger diameters under request
- Los actuadores neumáticos están calculados en base a una presión de aire de entrada de 6 Bares
Pneumatic actuators are calculated based on an inlet air pressure of 6 Bar

5115
5325115
 ACTUADOR
 ELÉCTRICO
 BAJO VOLTAJE
 ELECTRIC
 ACTUATOR
 LOW VOLTAGE



Válvula de mariposa tipo
 wafer disco cromado
 asiento rígido EPDM con
 actuador
 Butterfly valve wafer type
 chromed disc EPDM hard
 seat with actuator

5325115-050	5324020	310	169	181	110	2"
5325115-065	5324035	321	169	181	110	2 1/2"
5325115-080	5324055	356	196	181	110	3"
5325115-100	5324055	381	196	181	110	4"
5325115-125	5324085	396	196	181	128	5"
5325115-150	5324140	474	254	235	214	6"
5325115-200	5324300	514	254	235	214	8"
5325115-250	5324300	544	254	235	214	10"

- 12V VAC/VDC
- Para diámetros superiores consultar disponibilidad. Larger diameters under request

5115
5305115
 ACTUADOR
 ELÉCTRICO
 ALTO VOLTAJE
 ELECTRIC
 ACTUATOR
 HIGH VOLTAGE



Válvula de mariposa tipo
 wafer disco cromado
 asiento rígido EPDM con
 actuador
 Butterfly valve wafer type
 chromed disc EPDM hard
 seat with actuator

5305115-050	5300020	310	169	181	110	2"
5305115-065	5300035	321	169	181	110	2 1/2"
5305115-080	5300055	356	196	181	110	3"
5305115-100	5300055	381	196	181	110	4"
5305115-125	5300085	396	196	181	128	5"
5305115-150	5300140	474	254	235	214	6"
5305115-200	5300300	514	254	235	214	8"
5305115-250	5300300	544	254	235	214	10"

- 24V-240V VAC/VDC
- Para diámetros superiores consultar disponibilidad. Larger diameters under request

Para temperaturas superiores a 70°C se debe montar un puente separador entre la válvula y el actuador.
 At temperatures above 70°C separating bridge must be mounted between the valve and the actuator.

CÓDIGO CODE _____
 ACTUADOR ACTUATOR _____
H ALTURA DESDE EJE DE VÁLVULA A PARTE SUPERIOR DEL ACTUADOR
 HIGH FROM VALVE AXIS TO ACTUATOR TOP _____
F ALTURA DEL ACTUADOR ACTUATOR HIGH _____
A LONGITUD DEL ACTUADOR ACTUATOR LONGITUDE _____
G GROSOR DEL ACTUADOR ACTUATOR THICKNESS _____
 MEDIDA SIZE _____

51151
51051151
 SIMPLE EFECTO
 SIMPLE RETURN
 ACTUATOR



Válvula de mariposa tipo
 wafer disco inoxidable
 asiento rígido EPDM con
 actuador
 Butterfly valve wafer type
 stainless steel disc EPDM
 hard seat with actuator



51051151-040	5100052	215	92	145	71	1 1/2"
51051151-050	5100075	261	120	201	94	2"
51051151-065	5100075	272	120	201	94	2 1/2"
51051151-080	5100092	300	140	242	108,5	3"
51051151-100	5100105	338	153	275	122	4"
51051151-125	5100105	353	153	275	122	5"
51051151-150	5100105	373	153	275	122	6"
51051151-200	5100140	451,5	191,5	385	153	8"
51051151-250	5100160	507	217	450	174	10"
51051151-300	5100190	590	260	507	206	12"

- Actuadores neumáticos ATEX. Para diámetros superiores consultar disponibilidad
 Pneumatic actuators ATEX. Larger diameters under request
- Los actuadores neumáticos están calculados en base a una presión de aire de entrada de 6 Bares
 Pneumatic actuators are calculated based on a inlet air pressure of 6 Bar

51151
52051151
 DOBLE EFECTO
 DOUBLE ACTING
 ACTUATOR



Válvula de mariposa tipo
 wafer disco inoxidable
 asiento rígido EPDM con
 actuador
 Butterfly valve wafer type
 stainless steel disc EPDM
 hard seat with actuator



52051151-040	5200052	215	92	145	71	1 1/2"
52051151-050	5200052	233	92	145	71	2"
52051151-065	5200052	244	92	145	71	2 1/2"
52051151-080	5200075	280	120	201	94	3"
52051151-100	5200075	305	120	201	94	4"
52051151-125	5200075	320	120	201	94	5"
52051151-150	5200083	348	128	209	101	6"
52051151-200	5200105	408	153	275	122	8"
52051151-250	5200125	465	175	332	137,5	10"
52051151-300	5200140	521,5	191,5	385	153	12"

- Actuadores neumáticos ATEX. Para diámetros superiores consultar disponibilidad
 Pneumatic actuators ATEX. Larger diameters under request
- Los actuadores neumáticos están calculados en base a una presión de aire de entrada de 6 Bares
 Pneumatic actuators are calculated based on a inlet air pressure of 6 Bar

51151
53251151
 ACTUADOR
 ELÉCTRICO
 BAJO VOLTAJE
 ELECTRIC
 ACTUATOR
 LOW VOLTAGE



Válvula de mariposa tipo
 wafer disco inoxidable
 asiento rígido EPDM con
 actuador
 Butterfly valve wafer type
 stainless steel disc EPDM
 hard seat with actuator

53251151-040	5324020	300	169	181	110	1 1/2"
53251151-050	5324020	310	169	181	110	2"
53251151-065	5324035	321	169	181	110	2 1/2"
53251151-080	5324055	356	196	181	110	3"
53251151-100	5324055	381	196	181	110	4"
53251151-125	5324085	396	196	181	128	5"
53251151-150	5324140	416	196	181	128	6"
53251151-200	5324300	514	254	235	214	8"
53251151-250	5324300	544	254	235	214	10"

- 12V VAC/VDC
- Para diámetros superiores consultar disponibilidad. Larger diameters under request

51151
53051151
 ACTUADOR
 ELÉCTRICO
 ALTO VOLTAJE
 ELECTRIC
 ACTUATOR
 HIGH VOLTAGE



Válvula de mariposa tipo
 wafer disco inoxidable
 asiento rígido EPDM con
 actuador
 Butterfly valve wafer type
 stainless steel disc EPDM
 hard seat with actuator

53051151-040	5300020	300	169	181	110	1 1/2"
53051151-050	5300020	310	169	181	110	2"
53051151-065	5300035	321	169	181	110	2 1/2"
53051151-080	5300055	356	196	181	110	3"
53051151-100	5300055	381	196	181	110	4"
53051151-125	5300085	396	196	181	128	5"
53051151-150	5324140	416	196	181	128	6"
53051151-200	5300300	514	254	235	214	8"
53051151-250	5300300	544	254	235	214	10"

- 24V-240V VAC/VDC
- Para diámetros superiores consultar disponibilidad. Larger diameters under request

Para temperaturas superiores a 70°C se debe montar un puente separador entre la válvula y el actuador.
 At temperatures above 70°C separating bridge must be mounted between the valve and the actuator.

CÓDIGO CODE
 ACTUADOR ACTUATOR
H ALTURA DESDE EJE DE VÁLVULA A PARTE SUPERIOR DEL ACTUADOR
 HIGH FROM VALVE AXIS TO ACTUATOR TOP
F ALTURA DEL ACTUADOR ACTUATOR HIGH
A LONGITUD DEL ACTUADOR ACTUATOR LENGTH
G GROSOR DEL ACTUADOR ACTUATOR THICKNESS
 MEDIDA SIZE

5140
5105140
 SIMPLE EFECTO
 SIMPLE RETURN
 ACTUATOR



Válvula de mariposa tipo wafer EPDM disco poliámi- da 11 con actuador
 Butterfly valve wafer type stainless steel disc EPDM hard seat with actuator



5105140-050	5100075	276	120	201	94	2"
5105140-065	5100075	288	120	201	94	2 1/2"
5105140-080	5100092	316	140	242	108,5	3"
5105140-100	5100105	346	153	275	122	4"
5105140-125	5100140	384,5	191,5	385	153	5"
5105140-150	5100140	395,5	191,5	385	153	6"
5105140-200	5100190	527	260	507	206	8"
5105140-250	5100190	557	260	507	206	10"

- Actuadores neumáticos ATEX. Para diámetros superiores consultar disponibilidad
Pneumatic actuators ATEX. Larger diameters under request
- Los actuadores neumáticos están calculados en base a una presión de aire de entrada de 6 Bares
Pneumatic actuators are calculated based on a inlet air pressure of 6 Bar

5140
5205140
 DOBLE EFECTO
 DOUBLE ACTING
 ACTUATOR



Válvula de mariposa tipo wafer EPDM disco poliámi- da 11 con actuador
 Butterfly valve wafer type stainless steel disc EPDM hard seat with actuator



5205140-050	5200052	248	92	145	71	2"
5205140-065	5200052	260	92	145	71	2 1/2"
5205140-080	5200063	284	108	169	82	3"
5205140-100	5200075	313	120	201	94	4"
5205140-125	5200092	348	140	242	108,5	5"
5205140-150	5200092	344	140	242	108,5	6"
5205140-200	5200125	442	175	332	137,5	8"
5205140-250	5200125	472	175	332	137,5	10"

- Actuadores neumáticos ATEX. Para diámetros superiores consultar disponibilidad
Pneumatic actuators ATEX. Larger diameters under request
- Los actuadores neumáticos están calculados en base a una presión de aire de entrada de 6 Bares
Pneumatic actuators are calculated based on a inlet air pressure of 6 Bar

5140
5325140
 ACTUADOR
 ELÉCTRICO
 BAJO VOLTAJE
 ELECTRIC
 ACTUATOR
 LOW VOLTAGE



Válvula de mariposa tipo wafer EPDM disco poliámi- da 11 con actuador
 Butterfly valve wafer type stainless steel disc EPDM hard seat with actuator

5325140-050	5324020	325	169	181	110	2"
5325140-065	5324035	337	169	181	110	2 1/2"
5325140-080	5324055	345	169	181	110	3"
5325140-100	5324055	389	196	181	110	4"
5325140-125	5324140	447	254	235	214	5"
5325140-150	5324140	458	254	235	214	6"
5325140-200	5324300	521	254	235	214	8"

- 12V VAC/VDC
- Para diámetros superiores consultar disponibilidad. Larger diameters under request

5140
5305140
 ACTUADOR
 ELÉCTRICO
 ALTO VOLTAJE
 ELECTRIC
 ACTUATOR
 HIGH VOLTAGE



Válvula de mariposa tipo wafer EPDM disco poliámi- da 11 con actuador
 Butterfly valve wafer type stainless steel disc EPDM hard seat with actuator

5305140-050	5300020	325	169	181	110	2"
5305140-065	5300035	337	169	181	110	2 1/2"
5305140-080	5300055	345	169	181	110	3"
5305140-100	5300055	389	196	181	110	4"
5305140-125	5300140	447	254	235	214	5"
5305140-150	5300140	458	254	235	214	6"
5305140-200	5300300	521	254	235	214	8"

- 24V-240V VAC/VDC
- Para diámetros superiores consultar disponibilidad. Larger diameters under request

Para temperaturas superiores a 70°C se debe montar un puente separador entre la válvula y el actuador.
 At temperatures above 70°C separating bridge must be mounted between the valve and the actuator.

CÓDIGO CODE
 ACTUADOR ACTUATOR
 H ALTURA DESDE EJE DE VÁLVULA A PARTE SUPERIOR DEL ACTUADOR
 HIGH FROM VALVE AXIS TO ACTUATOR TOP
 F ALTURA DEL ACTUADOR ACTUATOR HIGH
 A LONGITUD DEL ACTUADOR ACTUATOR LONGITUDE
 G GROSOR DEL ACTUADOR ACTUATOR THICKNESS
 MEDIDA SIZE

51142
51051142
 SIMPLE EFECTO
 SIMPLE RETURN
 ACTUATOR



Válvula de mariposa tipo wafer disco inoxidable asiento blando NBR con actuador
 Butterfly valve wafer type stainless steel disc NBR soft seat with actuator



51051142-050	5100075	276	120	201	94	2"
51051142-065	5100075	288	120	201	94	2 1/2"
51051142-080	5100083	304	128	209	101	3"
51051142-100	5100083	321	128	209	101	4"
51051142-125	5100125	383	175	332	137,5	5"
51051142-150	5100125	394	175	332	137,5	6"
51051142-200	5100160	484	217	450	174	8"
51051142-250	5100190	557	260	507	206	10"

- Actuadores neumáticos ATEX. Para diámetros superiores consultar disponibilidad
Pneumatic actuators ATEX. Larger diameters under request
- Los actuadores neumáticos están calculados en base a una presión de aire de entrada de 6 Bares
Pneumatic actuators are calculated based on a inlet air pressure of 6 Bar

51142
52051142
 DOBLE EFECTO
 DOUBLE ACTING
 ACTUATOR



Válvula de mariposa tipo wafer disco inoxidable asiento blando NBR con actuador
 Butterfly valve wafer type stainless steel disc NBR soft seat with actuator



52051142-050	5200052	248	92	145	71	2"
52051142-065	5200052	260	92	145	71	2 1/2"
52051142-080	5200063	284	108	169	82	3"
52051142-100	5200063	301	108	169	82	4"
52051142-125	5200083	336	128	209	101	5"
52051142-150	5200092	359	140	242	109	6"
52051142-200	5200125	442	175	332	138	8"
52051142-250	5200140	489	192	385	153	10"

- Actuadores neumáticos ATEX. Para diámetros superiores consultar disponibilidad
Pneumatic actuators ATEX. Larger diameters under request
- Los actuadores neumáticos están calculados en base a una presión de aire de entrada de 6 Bares
Pneumatic actuators are calculated based on a inlet air pressure of 6 Bar

51142
53251142
 ACTUADOR ELÉCTRICO BAJO VOLTAJE
 ELECTRIC ACTUATOR LOW VOLTAGE



Válvula de mariposa tipo wafer disco inoxidable asiento blando NBR con actuador
 Butterfly valve wafer type stainless steel disc NBR soft seat with actuator

53251142-050	5324020	325	169	181	110	2"
53251142-065	5324035	337	169	181	110	2 1/2"
53251142-080	5324055	345	169	181	110	3"
53251142-100	5324055	389	196	181	110	4"
53251142-125	5324085	404	196	181	128	5"
53251142-150	5324140	458	254	235	214	6"
53251142-200	5324300	521	254	235	214	8"
53251142-250	5324300	551	254	235	214	10"

- 12V VAC/VDC
- Para diámetros superiores consultar disponibilidad. Larger diameters under request

51142
53051142
 ACTUADOR ELÉCTRICO ALTO VOLTAJE
 ELECTRIC ACTUATOR HIGH VOLTAGE



Válvula de mariposa tipo wafer disco inoxidable asiento blando NBR con actuador
 Butterfly valve wafer type stainless steel disc NBR soft seat with actuator

53051142-050	5300020	325	169	181	110	2"
53051142-065	5300035	337	169	181	110	2 1/2"
53051142-080	5300055	345	169	181	110	3"
53051142-100	5300055	389	196	181	110	4"
53051142-125	5300085	404	196	181	128	5"
53051142-150	5300140	458	254	235	214	6"
53051142-200	5300300	521	254	235	214	8"
53051142-250	5300300	551	254	235	214	10"

- 24V-240V VAC/VDC
- Para diámetros superiores consultar disponibilidad. Larger diameters under request

Para temperaturas superiores a 70°C se debe montar un puente separador entre la válvula y el actuador.
 At temperatures above 70°C separating bridge must be mounted between the valve and the actuator.

	CÓDIGO CODE	ACTUADOR ACTUATOR	H ALTURA DESDE EJE DE VÁLVULA A PARTE SUPERIOR DEL ACTUADOR HIGH FROM VALVE AXIS TO ACTUATOR TOP	F ALTURA DEL ACTUADOR ACTUATOR HIGH	A LONGITUD DEL ACTUADOR ACTUATOR LONGITUDE	G GROSOR DEL ACTUADOR ACTUATOR THICKNESS	MEDIDA SIZE
--	-------------	-------------------	---	-------------------------------------	--	--	-------------

5144
5105144
SIMPLE EFECTO
SIMPLE RETURN
ACTUATOR



Válvula de mariposa tipo
lug disco inoxidable asiento
blando NBR con actuador
Butterfly valve lug type
stainless steel disc NBR
soft seat with actuator



5105144-050	5100075	276	120	201	94	2"
5105144-065	5100083	296	128	209	101	2 1/2"
5105144-080	5100092	316	140	242	108,5	3"
5105144-100	5100105	346	153	275	122	4"
5105144-125	5100125	383	175	332	137,5	5"
5105144-150	5100140	415,5	191,5	385	153	6"
5105144-200	5100140	458,5	191,5	385	153	8"

- Actuadores neumáticos ATEX. Para diámetros superiores consultar disponibilidad
Pneumatic actuators ATEX. Larger diameters under request
- Los actuadores neumáticos están calculados en base a una presión de aire de entrada de 6 Bares
Pneumatic actuators are calculated based on an inlet air pressure of 6 Bar

5144
5205144
DOBLE EFECTO
DOUBLE ACTING
ACTUATOR



Válvula de mariposa tipo
lug disco inoxidable asiento
blando NBR con actuador
Butterfly valve lug type
stainless steel disc NBR
soft seat with actuator



5205144-050	5200052	248	92	145	71	2"
5205144-065	5200063	276	108	169	82	2 1/2"
5205144-080	5200075	296	120	201	94	3"
5205144-100	5200075	313	120	201	94	4"
5205144-125	5200092	348	140	242	108,5	5"
5205144-150	5200092	359	140	242	108,5	6"
5205144-200	5200105	420	153	275	122	8"

- Actuadores neumáticos ATEX. Para diámetros superiores consultar disponibilidad
Pneumatic actuators ATEX. Larger diameters under request
- Los actuadores neumáticos están calculados en base a una presión de aire de entrada de 6 Bares
Pneumatic actuators are calculated based on an inlet air pressure of 6 Bar

5144
5325144
ACTUADOR
ELÉCTRICO
BAJO VOLTAJE
ELECTRIC
ACTUATOR
LOW VOLTAGE



Válvula de mariposa tipo
lug disco inoxidable asiento
blando NBR con actuador
Butterfly valve lug type
stainless steel disc NBR
soft seat with actuator

5325144-050	5324020	325	169	181	110	2"
5325144-065	5324035	337	169	181	110	2 1/2"
5325144-080	5324055	372	196	181	110	3"
5325144-100	5324085	389	196	181	128	4"
5325144-125	5324140	447	254	235	214	5"
5325144-150	5324140	458	254	235	214	6"
5325144-200	5324300	521	254	235	214	8"

- 12V VAC/VDC
- Para diámetros superiores consultar disponibilidad. Larger diameters under request

5144
5305144
ACTUADOR
ELÉCTRICO
ALTO VOLTAJE
ELECTRIC
ACTUATOR
HIGH VOLTAGE



Válvula de mariposa tipo
lug disco inoxidable asiento
blando NBR con actuador
Butterfly valve lug type
stainless steel disc NBR
soft seat with actuator

5305144-050	5300020	325	169	181	110	2"
5305144-065	5300035	337	169	181	110	2 1/2"
5305144-080	5300055	372	196	181	110	3"
5305144-100	5300085	389	196	181	128	4"
5305144-125	5300140	447	254	235	214	5"
5305144-150	5300140	458	254	235	214	6"
5305144-200	5300300	521	254	235	214	8"

- 24V-240V VAC/VDC
- Para diámetros superiores consultar disponibilidad. Larger diameters under request

Para temperaturas superiores a 70°C se debe montar un puente separador entre la válvula y el actuador.
At temperatures above 70°C separating bridge must be mounted between the valve and the actuator.

CÓDIGO CODE
 ACTUADOR ACTUATOR
 H ALTURA DESDE EJE DE VÁLVULA A PARTE SUPERIOR DEL ACTUADOR
 HIGH FROM VALVE AXIS TO ACTUATOR TOP
 F ALTURA DEL ACTUADOR ACTUATOR HIGH
 A LONGITUD DEL ACTUADOR ACTUATOR LONGITUDE
 G GROSOR DEL ACTUADOR ACTUATOR THICKNESS
 MEDIDA SIZE

51442
51051442
 SIMPLE EFECTO
 SIMPLE RETURN
 ACTUATOR



Válvula de mariposa tipo
 lug disco inoxidable asiento
 blando EPDM con actuador
 Butterfly valve lug type
 stainless steel disc EPDM
 soft seat with actuator



51051442-050	5100075	276	120	201	94	2"
51051442-065	5100083	296	128	209	101	2 1/2"
51051442-080	5100092	316	140	242	108,5	3"
51051442-100	5100105	346	153	275	122	4"
51051442-125	5100125	383	175	332	137,5	5"
51051442-150	5100140	415,5	191,5	385	153	6"
51051442-200	5100140	458,5	191,5	385	153	8"

- Actuadores neumáticos ATEX. Para diámetros superiores consultar disponibilidad
 Pneumatic actuators ATEX. Larger diameters under request
- Los actuadores neumáticos están calculados en base a una presión de aire de entrada de 6 Bares
 Pneumatic actuators are calculated based on a inlet air pressure of 6 Bar

51442
52051442
 DOBLE EFECTO
 DOUBLE ACTING
 ACTUATOR



Válvula de mariposa tipo
 lug disco inoxidable asiento
 blando EPDM con actuador
 Butterfly valve lug type
 stainless steel disc EPDM
 soft seat with actuator



52051442-050	5200052	248	92	145	71	2"
52051442-065	5200063	276	108	169	82	2 1/2"
52051442-080	5200075	296	120	201	94	3"
52051442-100	5200075	313	120	201	94	4"
52051442-125	5200092	348	140	242	108,5	5"
52051442-150	5200092	359	140	242	108,5	6"
52051442-200	5200105	420	153	275	122	8"

- Actuadores neumáticos ATEX. Para diámetros superiores consultar disponibilidad
 Pneumatic actuators ATEX. Larger diameters under request
- Los actuadores neumáticos están calculados en base a una presión de aire de entrada de 6 Bares
 Pneumatic actuators are calculated based on a inlet air pressure of 6 Bar

51442
53251442
 ACTUADOR
 ELÉCTRICO
 BAJO VOLTAJE
 ELECTRIC
 ACTUATOR
 LOW VOLTAGE



Válvula de mariposa tipo
 lug disco inoxidable asiento
 blando EPDM con actuador
 Butterfly valve lug type
 stainless steel disc EPDM
 soft seat with actuator

53251442-050	5324020	325	169	181	110	2"
53251442-065	5324035	337	169	181	110	2 1/2"
53251442-080	5324055	372	196	181	110	3"
53251442-100	5324085	389	196	181	128	4"
53251442-125	5324140	447	254	235	214	5"
53251442-150	5324140	458	254	235	214	6"
53251442-200	5324300	521	254	235	214	8"

- 12V VAC/VDC
- Para diámetros superiores consultar disponibilidad. Larger diameters under request

51442
53051442
 ACTUADOR
 ELÉCTRICO
 ALTO VOLTAJE
 ELECTRIC
 ACTUATOR
 HIGH VOLTAGE



Válvula de mariposa tipo
 lug disco inoxidable asiento
 blando EPDM con actuador
 Butterfly valve lug type
 stainless steel disc EPDM
 soft seat with actuator

53051442-050	5300020	325	169	181	110	2"
53051442-065	5300035	337	169	181	110	2 1/2"
53051442-080	5300055	372	196	181	110	3"
53051442-100	5300085	389	196	181	128	4"
53051442-125	5300140	447	254	235	214	5"
53051442-150	5300140	458	254	235	214	6"
53051442-200	5300300	521	254	235	214	8"

- 24V-240V VAC/VDC
- Para diámetros superiores consultar disponibilidad. Larger diameters under request

Para temperaturas superiores a 70°C se debe montar un puente separador entre la válvula y el actuador.
 At temperatures above 70°C separating bridge must be mounted between the valve and the actuator.

CÓDIGO CODE _____
 ACTUADOR ACTUATOR _____
H ALTURA DESDE EJE DE VÁLVULA A PARTE SUPERIOR DEL ACTUADOR
 HIGH FROM VALVE AXIS TO ACTUATOR TOP _____
F ALTURA DEL ACTUADOR ACTUATOR HIGH _____
A LONGITUD DEL ACTUADOR ACTUATOR LONGITUDE _____
G GROSOR DEL ACTUADOR ACTUATOR THICKNESS _____
 MEDIDA SIZE _____

51143
51051143
 SIMPLE EFECTO
 SIMPLE RETURN
 ACTUATOR



Válvula de mariposa tipo
 wafer disco y asiento PTFE
 con actuador

Butterfly valve wafer type
 PTFE disc and seat with
 actuator



51051143-050	5100083	279	128	209	101	2"
51051143-065	5100083	283	128	209	101	2 1/2"
51051143-080	5100092	295	140	242	108,5	3"
51051143-100	5100105	326	153	275	122	4"
51051143-125	5100125	360	175	332	137,5	5"
51051143-150	5100140	401,5	191,5	385	153	6"
51051143-200	5100160	469	217	450	174	8"
51051143-250	-	-	-	-	-	10"
51051143-300	-	-	-	-	-	12"

- Actuadores neumáticos ATEX. Para diámetros superiores consultar disponibilidad
 Pneumatic actuators ATEX. Larger diameters under request
- Los actuadores neumáticos están calculados en base a una presión de aire de entrada de 6 Bares
 Pneumatic actuators are calculated based on a inlet air pressure of 6 Bar

51143
52051143
 DOBLE EFECTO
 DOUBLE ACTING
 ACTUATOR



Válvula de mariposa tipo
 wafer disco y asiento PTFE
 con actuador

Butterfly valve wafer type
 PTFE disc and seat with
 actuator



52051143-050	5200063	259	108	169	82	2"
52051143-065	5200063	263	108	169	82	2 1/2"
52051143-080	5200075	275	120	201	94	3"
52051143-100	5200083	301	128	209	101	4"
52051143-125	5200092	325	140	242	108,5	5"
52051143-150	5200105	343	153	275	122	6"
52051143-200	5200125	427	175	332	137,5	8"
52051143-250	-	-	-	-	-	10"
52051143-300	-	-	-	-	-	12"

- Actuadores neumáticos ATEX. Para diámetros superiores consultar disponibilidad
 Pneumatic actuators ATEX. Larger diameters under request
- Los actuadores neumáticos están calculados en base a una presión de aire de entrada de 6 Bares
 Pneumatic actuators are calculated based on a inlet air pressure of 6 Bar

51143
53251143
 ACTUADOR
 ELÉCTRICO
 BAJO VOLTAJE
 ELECTRIC
 ACTUATOR
 LOW VOLTAGE



Válvula de mariposa tipo
 wafer disco y asiento PTFE
 con actuador

Butterfly valve wafer type
 PTFE disc and seat with
 actuator

53251143-050	5324035	325	169	181	110	2"
53251143-065	5324035	337	169	181	110	2 1/2"
53251143-080	5324055	372	196	181	110	3"
53251143-100	5324085	389	196	181	128	4"
53251143-125	5324140	447	254	235	214	5"
53251143-150	5324140	458	254	235	214	6"
53251143-200	5324300	521	254	235	214	8"

- 12V VAC/VDC
- Para diámetros superiores consultar disponibilidad. Larger diameters under request

51143
53051143
 ACTUADOR
 ELÉCTRICO
 ALTO VOLTAJE
 ELECTRIC
 ACTUATOR
 HIGH VOLTAGE



Válvula de mariposa tipo
 wafer disco y asiento PTFE
 con actuador

Butterfly valve wafer type
 PTFE disc and seat with
 actuator

53051143-050	5300035	325	169	181	110	2"
53051143-065	5300035	337	169	181	110	2 1/2"
53051143-080	5300055	372	196	181	110	3"
53051143-100	5300085	389	196	181	128	4"
53051143-125	5300140	447	254	235	214	5"
53051143-150	5300140	458	254	235	214	6"
53051143-200	5300300	521	254	235	214	8"

- 24V-240V VAC/VDC
- Para diámetros superiores consultar disponibilidad. Larger diameters under request

Para temperaturas superiores a 70°C se debe montar un puente separador entre la válvula y el actuador.
 At temperatures above 70°C separating bridge must be mounted between the valve and the actuator.

CÓDIGO CODE _____
 ACTUADOR ACTUATOR _____
H ALTURA DESDE EJE DE VÁLVULA A PARTE SUPERIOR DEL ACTUADOR
 HIGH FROM VALVE AXIS TO ACTUATOR TOP _____
F ALTURA DEL ACTUADOR ACTUATOR HIGH _____
A LONGITUD DEL ACTUADOR ACTUATOR LONGITUDE _____
G GROSOR DEL ACTUADOR ACTUATOR THICKNESS _____
 MEDIDA SIZE _____

0917
5100917
 SIMPLE EFECTO
 SIMPLE RETURN
 ACTUATOR



Válvula esfera dos piezas
 roscar con pletina ISO y
 actuador
 Two pieces ball valve full
 bore threaded end ISO
 mounting pad with actuator



5100917-008	5100052	128,5	92	145	71	1/4"
5100917-010	5100052	129	92	145	71	3/8"
5100917-015	5100052	131	92	145	71	1/2"
5100917-020	5100052	133,5	92	145	71	3/4"
5100917-025	5100063	155	108	169	82	1"
5100917-032	5100075	172	120	201	94	1 1/4"
5100917-040	5100083	190	128	209	101	1 1/2"
5100917-050	5100092	211	140	242	108,5	2"

- Actuadores neumáticos ATEX
Pneumatic actuators ATEX
- Los actuadores neumáticos están calculados en base a una presión de aire de entrada de 6 Bares
Pneumatic actuators are calculated based on an inlet air pressure of 6 Bar

0917
5200917
 DOBLE EFECTO
 DOUBLE ACTING
 ACTUATOR



Válvula esfera dos piezas
 roscar con pletina ISO y
 actuador
 Two pieces ball valve full
 bore threaded end ISO
 mounting pad with actuator



5200917-008	5200052	128,5	92	145	71	1/4"
5200917-010	5200052	129	92	145	71	3/8"
5200917-015	5200052	131	92	145	71	1/2"
5200917-020	5200052	133,5	92	145	71	3/4"
5200917-025	5200052	139	92	145	71	1"
5200917-032	5200063	160	108	169	82	1 1/4"
5200917-040	5200075	182	120	201	94	1 1/2"
5200917-050	5200075	191	120	201	94	2"

- Actuadores neumáticos ATEX
Pneumatic actuators ATEX
- Los actuadores neumáticos están calculados en base a una presión de aire de entrada de 6 Bares
Pneumatic actuators are calculated based on an inlet air pressure of 6 Bar

0917
5320917
 ACTUADOR
 ELÉCTRICO
 BAJO VOLTAJE
 ELECTRIC
 ACTUATOR
 LOW VOLTAGE



Válvula esfera dos piezas
 roscar con pletina ISO y
 actuador
 Two pieces ball valve full
 bore threaded end ISO
 mounting pad with actuator

5320917-008**	5324010	160,5	124	169	104	1/4"
5320917-010**	5324010	161	124	169	104	3/8"
5320917-015**	5324010	163	124	169	104	1/2"
5320917-020*	5324020	210,5	169	181	110	3/4"
5320917-025*	5324020	216	169	181	110	1"
5320917-032*	5324035	221	169	181	110	1 1/4"
5320917-040*	5324035	231	169	181	110	1 1/2"
5320917-050*	5324055	267	196	181	110	2"

- *12V VAC/VDC **24V VAC/VDC

0917
5300917
 ACTUADOR
 ELÉCTRICO
 ALTO VOLTAJE
 ELECTRIC
 ACTUATOR
 HIGH VOLTAGE



Válvula esfera dos piezas
 roscar con pletina ISO y
 actuador
 Two pieces ball valve full
 bore threaded end ISO
 mounting pad with actuator

5300917-008**	5300010	160,5	124	169	104	1/4"
5300917-010**	5300010	161	124	169	104	3/8"
5300917-015**	5300010	163	124	169	104	1/2"
5300917-020*	5300020	211	169	181	110	3/4"
5300917-025*	5300020	216	169	181	110	1"
5300917-032*	5300035	221	169	181	110	1 1/4"
5300917-040*	5300035	231	169	181	110	1 1/2"
5300917-050*	5300055	267	196	181	110	2"

- *24V-240V VAC/VDC ** 85V VAC/VDC

Para temperaturas superiores a 70°C se debe montar un puente separador entre la válvula y el actuador.
 At temperatures above 70°C separating bridge must be mounted between the valve and the actuator.

CÓDIGO CODE
 ACTUADOR ACTUATOR
H ALTURA DESDE EJE DE VÁLVULA A PARTE SUPERIOR DEL ACTUADOR
 HIGH FROM VALVE AXIS TO ACTUATOR TOP
F ALTURA DEL ACTUADOR ACTUATOR HIGH
A LONGITUD DEL ACTUADOR ACTUATOR LENGTH
G GROSOR DEL ACTUADOR ACTUATOR THICKNESS
 MEDIDA SIZE

0918
5100918
 SIMPLE EFECTO
 SIMPLE RETURN
 ACTUATOR



Válvula esfera tres vías
 paso en L con pletina ISO y
 actuador
 Three way ball valve L-type
 full bore ISO mounting pad
 with actuator



5100918-008	5100052	134	92	145	71	1/4"
5100918-010	5100052	134	92	145	71	3/8"
5100918-015	5100052	134	92	145	71	1/2"
5100918-020	5100063	157	108	169	82	3/4"
5100918-025	5100063	168	108	169	82	1"
5100918-032	5100083	191	128	209	101	1 1/4"
5100918-040	5100083	202	128	209	101	1 1/2"
5100918-050	5100092	223	140	242	108,5	2"

- Actuadores neumáticos ATEX
Pneumatic actuators ATEX
- Los actuadores neumáticos están calculados en base a una presión de aire de entrada de 6 Bares
Pneumatic actuators are calculated based on an inlet air pressure of 6 Bar

0918
5200918
 DOBLE EFECTO
 DOUBLE ACTING
 ACTUATOR



Válvula esfera tres vías
 paso en L con pletina ISO y
 actuador
 Three way ball valve L-type
 full bore ISO mounting pad
 with actuator



5200918-008	5200052	134	92	145	71	1/4"
5200918-010	5200052	134	92	145	71	3/8"
5200918-015	5200052	134	92	145	71	1/2"
5200918-020	5200052	141	92	145	71	3/4"
5200918-025	5200052	152	92	145	71	1"
5200918-032	5200063	171	108	169	82	1 1/4"
5200918-040	5200063	182	108	169	82	1 1/2"
5200918-050	5200075	203	120	201	94	2"

- Actuadores neumáticos ATEX
Pneumatic actuators ATEX
- Los actuadores neumáticos están calculados en base a una presión de aire de entrada de 6 Bares
Pneumatic actuators are calculated based on an inlet air pressure of 6 Bar

0918
5320918
 ACTUADOR
 ELÉCTRICO
 BAJO VOLTAJE
 ELECTRIC
 ACTUATOR
 LOW VOLTAGE



Válvula esfera tres vías
 paso en L con pletina ISO y
 actuador
 Three way ball valve L-type
 full bore ISO mounting pad
 with actuator

5320918-008	5324020	211	169	181	110	1/4"
5320918-010	5324020	211	169	181	110	3/8"
5320918-015	5324020	211	169	181	110	1/2"
5320918-020	5324020	218	169	181	110	3/4"
5320918-025	5324020	229	169	181	110	1"
5320918-032	5324035	232	169	181	110	1 1/4"
5320918-040	5324055	243	169	181	110	1 1/2"
5320918-050	5324085	279	196	181	128	2"

- 12V VAC/VDC

0918
5300918
 ACTUADOR
 ELÉCTRICO
 ALTO VOLTAJE
 ELECTRIC
 ACTUATOR
 HIGH VOLTAGE



Válvula esfera tres vías
 paso en L con pletina ISO y
 actuador
 Three way ball valve L-type
 full bore ISO mounting pad
 with actuator

5300918-008	5300020	211	169	181	110	1/4"
5300918-010	5300020	211	169	181	110	3/8"
5300918-015	5300020	211	169	181	110	1/2"
5300918-020	5300020	218	169	181	110	3/4"
5300918-025	5300020	229	169	181	110	1"
5300918-032	5300035	232	169	181	110	1 1/4"
5300918-040	5300055	243	169	181	110	1 1/2"
5300918-050	5300085	279	196	181	128	2"

- 24V-240V VAC/VDC

Para temperaturas superiores a 70°C se debe montar un puente separador entre la válvula y el actuador.
 At temperatures above 70°C separating bridge must be mounted between the valve and the actuator.

CÓDIGO CODE
 ACTUADOR ACTUATOR
H ALTURA DESDE EJE DE VÁLVULA A PARTE SUPERIOR DEL ACTUADOR
 HIGH FROM VALVE AXIS TO ACTUATOR TOP
F ALTURA DEL ACTUADOR ACTUATOR HIGH
A LONGITUD DEL ACTUADOR ACTUATOR LENGTH
G GROSOR DEL ACTUADOR ACTUATOR THICKNESS
 MEDIDA SIZE

0919
5100919
 SIMPLE EFECTO
 SIMPLE RETURN
 ACTUATOR



Válvula esfera tres vías
 paso en T con pletina ISO y
 actuador
 Three way ball valve T-type
 full bore ISO mounting pad
 with actuator



5100919-008	5100052	134	92	145	71	1/4"
5100919-010	5100052	134	92	145	71	3/8"
5100919-015	5100052	134	92	145	71	1/2"
5100919-020	5100063	157	108	169	82	3/4"
5100919-025	5100063	168	108	169	82	1"
5100919-032	5100083	191	128	209	101	1 1/4"
5100919-040	5100083	202	128	209	101	1 1/2"
5100919-050	5100092	223	140	242	108,5	2"

- Actuadores neumáticos ATEX
Pneumatic actuators ATEX
- Los actuadores neumáticos están calculados en base a una presión de aire de entrada de 6 Bares
Pneumatic actuators are calculated based on an inlet air pressure of 6 Bar

0919
5200919
 DOBLE EFECTO
 DOUBLE ACTING
 ACTUATOR



Válvula esfera tres vías
 paso en T con pletina ISO y
 actuador
 Three way ball valve T-type
 full bore ISO mounting pad
 with actuator



5200919-008	5200052	134	92	145	71	1/4"
5200919-010	5200052	134	92	145	71	3/8"
5200919-015	5200052	134	92	145	71	1/2"
5200919-020	5200052	141	92	145	71	3/4"
5200919-025	5200052	152	92	145	71	1"
5200919-032	5200063	171	108	169	82	1 1/4"
5200919-040	5200063	182	108	169	82	1 1/2"
5200919-050	5200075	203	120	201	94	2"

- Actuadores neumáticos ATEX
Pneumatic actuators ATEX
- Los actuadores neumáticos están calculados en base a una presión de aire de entrada de 6 Bares
Pneumatic actuators are calculated based on an inlet air pressure of 6 Bar

0919
5320919
 ACTUADOR
 ELÉCTRICO
 BAJO VOLTAJE
 ELECTRIC
 ACTUATOR
 LOW VOLTAGE



Válvula esfera tres vías
 paso en T con pletina ISO y
 actuador
 Three way ball valve T-type
 full bore ISO mounting pad
 with actuator

5320919-008	5324020	211	169	181	110	1/4"
5320919-010	5324020	211	169	181	110	3/8"
5320919-015	5324020	211	169	181	110	1/2"
5320919-020	5324020	218	169	181	110	3/4"
5320919-025	5324020	229	169	181	110	1"
5320919-032	5324035	232	169	181	110	1 1/4"
5320919-040	5324055	243	169	181	110	1 1/2"
5320919-050	5324085	279	196	181	128	2"

- 12V VAC/VDC

0919
5300919
 ACTUADOR
 ELÉCTRICO
 ALTO VOLTAJE
 ELECTRIC
 ACTUATOR
 HIGH VOLTAGE



Válvula esfera tres vías
 paso en T con pletina ISO y
 actuador
 Three way ball valve T-type
 full bore ISO mounting pad
 with actuator

5300919-008	5300020	211	169	181	110	1/4"
5300919-010	5300020	211	169	181	110	3/8"
5300919-015	5300020	211	169	181	110	1/2"
5300919-020	5300020	218	169	181	110	3/4"
5300919-025	5300020	229	169	181	110	1"
5300919-032	5300035	232	169	181	110	1 1/4"
5300919-040	5300055	243	169	181	110	1 1/2"
5300919-050	5300085	279	196	181	128	2"

- 24V-240V VAC/VDC

Para temperaturas superiores a 70°C se debe montar un puente separador entre la válvula y el actuador.
 At temperatures above 70°C separating bridge must be mounted between the valve and the actuator.

CÓDIGO CODE
 ACTUADOR ACTUATOR
H ALTURA DESDE EJE DE VÁLVULA A PARTE SUPERIOR DEL ACTUADOR
 HIGH FROM VALVE AXIS TO ACTUATOR TOP
F ALTURA DEL ACTUADOR ACTUATOR HIGH
A LONGITUD DEL ACTUADOR ACTUATOR LENGTH
G GROSOR DEL ACTUADOR ACTUATOR THICKNESS
 MEDIDA SIZE

5117
5105117
 SIMPLE EFECTO
 SIMPLE RETURN
 ACTUATOR



Válvula esfera dos piezas
 acero al carbono bola
 A-316 brida con actuador
 Two pieces ball valves
 WCB flanged end with
 actuator



5105117-015	5100052	141	92	145	71	1/2"
5105117-020	5100052	146	92	145	71	3/4"
5105117-025	5100063	167	108	169	82	1"
5105117-032	5100075	191	120	201	94	1 1/4"
5105117-040	5100083	206	128	209	101	1 1/2"
5105117-050	5100092	225	140	242	108,5	2"
5105117-065	5100105	253	153	275	122	2 1/2"
5105117-080	5100125	285	175	332	137,5	3"
5105117-100	5100160	347	217	450	174	4"
5105117-125	5100190	445	260	507	206	5"
5105117-150	5100210	485	285	562	226	6"
5105117-200	-	-	-	-	-	8"

- Actuadores neumáticos ATEX
Pneumatic actuators ATEX

- Los actuadores neumáticos están calculados en base a una presión de aire de entrada de 6 Bares
Pneumatic actuators are calculated based on an inlet air pressure of 6 Bar

5117
5205117
 DOBLE EFECTO
 DOUBLE ACTING
 ACTUATOR



Válvula esfera dos piezas
 acero al carbono bola
 A-316 brida con actuador
 Two pieces ball valves
 WCB flanged end with
 actuator



5205117-015	5200052	141	92	145	71	1/2"
5205117-020	5200052	146	92	145	71	3/4"
5205117-025	5200052	151	92	145	71	1"
5205117-032	5200052	163	92	145	71	1 1/4"
5205117-040	5200063	186	108	169	82	1 1/2"
5205117-050	5200075	205	120	201	94	2"
5205117-065	5200083	228	128	209	101	2 1/2"
5205117-080	5200092	250	140	242	108,5	3"
5205117-100	5200125	305	175	332	137,5	4"
5205117-125	5200140	356,5	191,5	385	153	5"
5205117-150	5200160	397	217	450	174	6"
5205117-200	-	-	-	-	-	8"

- Actuadores neumáticos ATEX
Pneumatic actuators ATEX

- Los actuadores neumáticos están calculados en base a una presión de aire de entrada de 6 Bares
Pneumatic actuators are calculated based on an inlet air pressure of 6 Bar

5117
5325117
 ACTUADOR
 ELÉCTRICO
 BAJO VOLTAJE
 ELECTRIC
 ACTUATOR
 LOW VOLTAGE



Válvula esfera dos piezas
 acero al carbono bola
 A-316 brida con actuador
 Two pieces ball valves
 WCB flanged end with
 actuator

5325117-015**	5324010	173	124	169	104	1/2"
5325117-020**	5324010	178	124	169	104	3/4"
5325117-025*	5324020	228	169	181	110	1"
5325117-032*	5324035	240	169	181	110	1 1/4"
5325117-040*	5324035	247	169	181	110	1 1/2"
5325117-050*	5324055	281	196	181	110	2"
5325117-065*	5324085	296	196	181	128	2 1/2"
5325117-080*	5324140	364	254	235	214	3"
5325117-100*	5324300	384	254	235	214	4"

- *12V VAC/VDC **24V VAC/VDC

5117
5305117
 ACTUADOR
 ELÉCTRICO
 ALTO VOLTAJE
 ELECTRIC
 ACTUATOR
 HIGH VOLTAGE



Válvula esfera dos piezas
 acero al carbono bola
 A-316 brida con actuador
 Two pieces ball valves
 WCB flanged end with
 actuator

5305117-015**	5300010	173	124	169	104	1/2"
5305117-020**	5300010	178	124	169	104	3/4"
5305117-025*	5300020	228	169	181	110	1"
5305117-032*	5300035	240	169	181	110	1 1/4"
5305117-040*	5300035	247	169	181	110	1 1/2"
5305117-050*	5300055	281	196	181	110	2"
5305117-065*	5300085	296	196	181	128	2 1/2"
5305117-080*	5300140	364	254	235	214	3"
5305117-100*	5300300	384	254	235	214	4"

- *24V-240V VAC/VDC ** 85V VAC/VDC

Para temperaturas superiores a 70°C se debe montar un puente separador entre la válvula y el actuador.
 At temperatures above 70°C separating bridge must be mounted between the valve and the actuator.

CÓDIGO CODE
 ACTUADOR ACTUATOR
H ALTURA DESDE EJE DE VÁLVULA A PARTE SUPERIOR DEL ACTUADOR
 HIGH FROM VALVE AXIS TO ACTUATOR TOP
F ALTURA DEL ACTUADOR ACTUATOR HIGH
A LONGITUD DEL ACTUADOR ACTUATOR LONGITUDE
G GROSOR DEL ACTUADOR ACTUATOR THICKNESS
 MEDIDA SIZE

5128
5105128
 SIMPLE EFECTO
 SIMPLE RETURN
 ACTUATOR



Válvula esfera dos piezas
 inoxidable brida actuada
 Two pieces ball valve
 stainless steel flanged end
 with actuator



5105128-015	5100052	141	92	145	71	1/2"
5105128-020	5100052	146	92	145	71	3/4"
5105128-025	5100063	167	108	169	82	1"
5105128-032	5100075	191	120	201	94	1 1/4"
5105128-040	5100083	206	128	209	101	1 1/2"
5105128-050	5100092	225	140	242	108,5	2"
5105128-065	5100105	253	153	275	122	2 1/2"
5105128-080	5100125	285	175	332	137,5	3"
5105128-100	5100140	321,5	191,5	385	153	4"
5105128-125	5100160	382	217	450	174	5"
5105128-150	5100210	485	285	562	226	6"

- Actuadores neumáticos ATEX
Pneumatic actuators ATEX
- Los actuadores neumáticos están calculados en base a una presión de aire de entrada de 6 Bares
Pneumatic actuators are calculated based on a inlet air pressure of 6 Bar

5128
5205128
 DOBLE EFECTO
 DOUBLE ACTING
 ACTUATOR



Válvula esfera dos piezas
 inoxidable brida actuada
 Two pieces ball valve
 stainless steel flanged end
 with actuator



5205128-015	5200052	141	92	145	71	1/2"
5205128-020	5200052	146	92	145	71	3/4"
5205128-025	5200052	151	92	145	71	1"
5205128-032	5200052	163	92	145	71	1 1/4"
5205128-040	5200063	186	108	169	82	1 1/2"
5205128-050	5200075	205	120	201	94	2"
5205128-065	5200083	228	128	209	101	2 1/2"
5205128-080	5200092	250	140	242	108,5	3"
5205128-100	5200125	305	175	332	137,5	4"
5205128-125	5200140	356,5	191,5	385	153	5"
5205128-150	5200160	397	217	450	174	6"

- Actuadores neumáticos ATEX
Pneumatic actuators ATEX
- Los actuadores neumáticos están calculados en base a una presión de aire de entrada de 6 Bares
Pneumatic actuators are calculated based on a inlet air pressure of 6 Bar

5128
5325128
 ACTUADOR
 ELÉCTRICO
 BAJO VOLTAJE
 ELECTRIC
 ACTUATOR
 LOW VOLTAGE



Válvula esfera dos piezas
 inoxidable brida actuada
 Two pieces ball valve
 stainless steel flanged end
 with actuator

5325128-015**	5324010	173	124	169	104	1/2"
5325128-020**	5324010	178	124	169	104	3/4"
5325128-025*	5324020	228	169	181	110	1"
5325128-032*	5324035	240	169	181	110	1 1/4"
5325128-040*	5324035	247	169	181	110	1 1/2"
5325128-050*	5324055	281	196	181	110	2"
5325128-065*	5324085	296	196	181	128	2 1/2"
5325128-080*	5324140	364	254	235	214	3"
5325128-100*	5324140	384	254	235	214	4"

- *12V VAC/VDC **24V VAC/VDC

5128
5305128
 ACTUADOR
 ELÉCTRICO
 ALTO VOLTAJE
 ELECTRIC
 ACTUATOR
 HIGH VOLTAGE



Válvula esfera dos piezas
 inoxidable brida actuada
 Two pieces ball valve
 stainless steel flanged end
 with actuator

5305128-015**	5300010	173	124	169	104	1/2"
5305128-020**	5300010	178	124	169	104	3/4"
5305128-025*	5300020	228	169	181	110	1"
5305128-032*	5300035	240	169	181	110	1 1/4"
5305128-040*	5300035	247	169	181	110	1 1/2"
5305128-050*	5300055	281	196	181	110	2"
5305128-065*	5300085	296	196	181	128	2 1/2"
5305128-080*	5300140	364	254	235	214	3"
5305128-100*	5300140	384	254	235	214	4"

- *24V-240V VAC/VDC ** 85V VAC/VDC

Para temperaturas superiores a 70°C se debe montar un puente separador entre la válvula y el actuador.
 At temperatures above 70°C separating bridge must be mounted between the valve and the actuator.

CÓDIGO CODE _____
 ACTUADOR ACTUATOR _____
H ALTURA DESDE EJE DE VÁLVULA A PARTE SUPERIOR DEL ACTUADOR
 HIGH FROM VALVE AXIS TO ACTUATOR TOP _____
F ALTURA DEL ACTUADOR ACTUATOR HIGH _____
A LONGITUD DEL ACTUADOR ACTUATOR LONGITUDE _____
G GROSOR DEL ACTUADOR ACTUATOR THICKNESS _____
 MEDIDA SIZE _____

91120
51091120
 SIMPLE EFECTO
 SIMPLE RETURN
 ACTUATOR



Válvula esfera tres piezas
 Socked Weld paso total
 con pletina ISO y actuador
 Three pieces ball valve
 Socked Weld full bore ISO
 mounting pad with actuator

ATEX 

51091120-015	5100052	131	92	145	71	1/2"
51091120-020	5100052	133,5	92	145	71	3/4"
51091120-025	5100063	155	108	169	82	1"
51091120-032	5100063	160	108	169	82	1 1/4"
51091120-040	5100075	182	120	201	94	1 1/2"
51091120-050	5100083	199	128	209	101	2"
51091120-065	5100092	229	140	242	108,5	2 1/2"
51091120-080	5100105	-	-	-	-	3"
51091120-100	5100140	-	-	-	-	4"

- Actuadores neumáticos ATEX
Pneumatic actuators ATEX
- Los actuadores neumáticos están calculados en base a una presión de aire de entrada de 6 Bares
Pneumatic actuators are calculated based on an inlet air pressure of 6 Bar

91120
52091120
 DOBLE EFECTO
 DOUBLE ACTING
 ACTUATOR



Válvula esfera tres piezas
 Socked Weld paso total
 con pletina ISO y actuador
 Three pieces ball valve
 Socked Weld full bore ISO
 mounting pad with actuator

ATEX 

52091120-015	5200052	131	92	145	71	1/2"
52091120-020	5200052	133,5	92	145	71	3/4"
52091120-025	5200052	139	92	145	71	1"
52091120-032	5200052	144	92	145	71	1 1/4"
52091120-040	5200063	170	108	169	82	1 1/2"
52091120-050	5200063	179	108	169	82	2"
52091120-065	5200083	217	128	209	101	2 1/2"
52091120-080	5200083	-	-	-	-	3"
52091120-100	5200125	-	-	-	-	4"

- Actuadores neumáticos ATEX
Pneumatic actuators ATEX
- Los actuadores neumáticos están calculados en base a una presión de aire de entrada de 6 Bares
Pneumatic actuators are calculated based on an inlet air pressure of 6 Bar

91120
53291120
 ACTUADOR
 ELÉCTRICO
 BAJO VOLTAJE
 ELECTRIC
 ACTUATOR
 LOW VOLTAGE



Válvula esfera tres piezas
 Socked Weld paso total
 con pletina ISO y actuador
 Three pieces ball valve
 Socked Weld full bore ISO
 mounting pad with actuator

53291120-015**	5324010	163	124	169	104	1/2"
53291120-020*	5324020	210,5	169	181	110	3/4"
53291120-025*	5324020	216	169	181	110	1"
53291120-032*	5324035	221	169	181	110	1 1/4"
53291120-040*	5324035	231	169	181	110	1 1/2"
53291120-050*	5324055	267	196	181	110	2"
53291120-065*	5324055	285	196	181	110	2 1/2"
53291120-080*	5324085	-	-	-	-	3"
53291120-100*	5324140	-	-	-	-	4"

- *12V VAC/VDC **24V VAC/VDC

91120
53091120
 ACTUADOR
 ELÉCTRICO
 ALTO VOLTAJE
 ELECTRIC
 ACTUATOR
 HIGH VOLTAGE



Válvula esfera tres piezas
 Socked Weld paso total
 con pletina ISO y actuador
 Three pieces ball valve
 Socked Weld full bore ISO
 mounting pad with actuator

53091120-015**	5300010	163	124	169	104	1/2"
53091120-020*	5300020	210,5	169	181	110	3/4"
53091120-025*	5300020	216	169	181	110	1"
53091120-032*	5300035	221	169	181	110	1 1/4"
53091120-040*	5300035	231	169	181	110	1 1/2"
53091120-050*	5300055	267	196	181	110	2"
53091120-065*	5300055	285	196	181	110	2 1/2"
53091120-080*	5300085	-	-	-	-	3"
53091120-100*	5300140	-	-	-	-	4"

- *24V-240V VAC/VDC ** 85V VAC/VDC

Para temperaturas superiores a 70°C se debe montar un puente separador entre la válvula y el actuador.
 At temperatures above 70°C separating bridge must be mounted between the valve and the actuator.

CÓDIGO CODE
 ACTUADOR ACTUATOR
 H ALTURA DESDE EJE DE VÁLVULA A PARTE SUPERIOR DEL ACTUADOR
 HIGH FROM VALVE AXIS TO ACTUATOR TOP
 F ALTURA DEL ACTUADOR ACTUATOR HIGH
 A LONGITUD DEL ACTUADOR ACTUATOR LONGITUDE
 G GROSOR DEL ACTUADOR ACTUATOR THICKNESS
 MEDIDA SIZE

91020
51091020
 SIMPLE EFECTO
 SIMPLE RETURN
 ACTUATOR



Válvula esfera tres piezas
 Butt Weld paso total con
 pletina ISO y actuador
 Three pieces ball valve Butt
 Weld full bore ISO mount-
 ing pad with actuator



51091020-015	5100052	131	92	145	71	1/2"
51091020-020	5100052	133,5	92	145	71	3/4"
51091020-025	5100063	155	108	169	82	1"
51091020-032	5100063	160	108	169	82	1 1/4"
51091020-040	5100075	182	120	201	94	1 1/2"
51091020-050	5100083	199	128	209	101	2"
51091020-065	5100092	229	140	242	108,5	2 1/2"
51091020-080	5100105	-	-	-	-	3"
51091020-100	5100140	-	-	-	-	4"

- Actuadores neumáticos ATEX
Pneumatic actuators ATEX
- Los actuadores neumáticos están calculados en base a una presión de aire de entrada de 6 Bares
Pneumatic actuators are calculated based on an inlet air pressure of 6 Bar

91020
52091020
 DOBLE EFECTO
 DOUBLE ACTING
 ACTUATOR



Válvula esfera tres piezas
 Butt Weld paso total con
 pletina ISO y actuador
 Three pieces ball valve Butt
 Weld full bore ISO mount-
 ing pad with actuator



52091020-015	5200052	131	92	145	71	1/2"
52091020-020	5200052	133,5	92	145	71	3/4"
52091020-025	5200052	139	92	145	71	1"
52091020-032	5200052	144	92	145	71	1 1/4"
52091020-040	5200063	170	108	169	82	1 1/2"
52091020-050	5200063	179	108	169	82	2"
52091020-065	5200083	217	128	209	101	2 1/2"
52091020-080	5200083	-	-	-	-	3"
52091020-100	5200125	-	-	-	-	4"

- Actuadores neumáticos ATEX
Pneumatic actuators ATEX
- Los actuadores neumáticos están calculados en base a una presión de aire de entrada de 6 Bares
Pneumatic actuators are calculated based on an inlet air pressure of 6 Bar

91020
53291020
 ACTUADOR
 ELÉCTRICO
 BAJO VOLTAJE
 ELECTRIC
 ACTUATOR
 LOW VOLTAGE



Válvula esfera tres piezas
 Butt Weld paso total con
 pletina ISO y actuador
 Three pieces ball valve Butt
 Weld full bore ISO mount-
 ing pad with actuator

53291020-015**	5324010	163	124	169	104	1/2"
53291020-020*	5324020	210,5	169	181	110	3/4"
53291020-025*	5324020	216	169	181	110	1"
53291020-032*	5324035	221	169	181	110	1 1/4"
53291020-040*	5324035	231	169	181	110	1 1/2"
53291020-050*	5324055	267	196	181	110	2"
53291020-065*	5324055	285	196	181	110	2 1/2"
53291020-080*	5324085	-	-	-	-	3"
53291020-100*	5324140	-	-	-	-	4"

- *12V VAC/VDC **24V VAC/VDC

91020
53091020
 ACTUADOR
 ELÉCTRICO
 ALTO VOLTAJE
 ELECTRIC
 ACTUATOR
 HIGH VOLTAGE



Válvula esfera tres piezas
 Butt Weld paso total con
 pletina ISO y actuador
 Three pieces ball valve Butt
 Weld full bore ISO mount-
 ing pad with actuator

53091020-015**	5300010	163	124	169	104	1/2"
53091020-020*	5300020	210,5	169	181	110	3/4"
53091020-025*	5300020	216	169	181	110	1"
53091020-032*	5300035	221	169	181	110	1 1/4"
53091020-040*	5300035	231	169	181	110	1 1/2"
53091020-050*	5300055	267	196	181	110	2"
53091020-065*	5300055	285	196	181	110	2 1/2"
53091020-080*	5300085	-	-	-	-	3"
53091020-100*	5300140	-	-	-	-	4"

- *24V-240V VAC/VDC ** 85V VAC/VDC

Para temperaturas superiores a 70°C se debe montar un puente separador entre la válvula y el actuador.
 At temperatures above 70°C separating bridge must be mounted between the valve and the actuator.

CÓDIGO CODE
 ACTUADOR ACTUATOR
H ALTURA DESDE EJE DE VÁLVULA A PARTE SUPERIOR DEL ACTUADOR
 HIGH FROM VALVE AXIS TO ACTUATOR TOP
F ALTURA DEL ACTUADOR ACTUATOR HIGH
A LONGITUD DEL ACTUADOR ACTUATOR LENGTH
G GROSOR DEL ACTUADOR ACTUATOR THICKNESS
 MEDIDA SIZE

0912
5100912
 SIMPLE EFECTO
 SIMPLE RETURN
 ACTUATOR



Válvula tres piezas roscar paso total con pletina ISO y actuador

Three pieces ball valve threaded full bore ISO mounting pad with actuator



5100912-008	5100052	131	92	145	71	1/4"
5100912-010	5100052	131	92	145	71	3/8"
5100912-015	5100052	131	92	145	71	1/2"
5100912-020	5100052	133,5	92	145	71	3/4"
5100912-025	5100063	155	108	169	82	1"
5100912-032	5100063	160	108	169	82	1 1/4"
5100912-040	5100075	182	120	201	94	1 1/2"
5100912-050	5100083	199	128	209	101	2"
5100912-065	5100092	229	140	242	108,5	2 1/2"
5100912-080	5100105	251	153	275	122	3"
5100912-100	5100140	-	-	-	-	4"

- Actuadores neumáticos ATEX
Pneumatic actuators ATEX
- Los actuadores neumáticos están calculados en base a una presión de aire de entrada de 6 Bares
Pneumatic actuators are calculated based on an inlet air pressure of 6 Bar

0912
5200912
 DOBLE EFECTO
 DOUBLE ACTING
 ACTUATOR



Válvula tres piezas roscar paso total con pletina ISO y actuador

Three pieces ball valve threaded full bore ISO mounting pad with actuator



5200912-008	5200052	131	92	145	71	1/4"
5200912-010	5200052	131	92	145	71	3/8"
5200912-015	5200052	131	92	145	71	1/2"
5200912-020	5200052	133,5	92	145	71	3/4"
5200912-025	5200052	139	92	145	71	1"
5200912-032	5200052	144	92	145	71	1 1/4"
5200912-040	5200063	170	108	169	82	1 1/2"
5200912-050	5200063	179	108	169	82	2"
5200912-065	5200083	217	128	209	101	2 1/2"
5200912-080	5200083	226	128	209	101	3"
5200912-100	5200125	-	-	-	-	4"

- Actuadores neumáticos ATEX
Pneumatic actuators ATEX
- Los actuadores neumáticos están calculados en base a una presión de aire de entrada de 6 Bares
Pneumatic actuators are calculated based on an inlet air pressure of 6 Bar

0912
5320912
 ACTUADOR ELÉCTRICO BAJO VOLTAJE
 ELECTRIC ACTUATOR LOW VOLTAGE



Válvula tres piezas roscar paso total con pletina ISO y actuador

Three pieces ball valve threaded full bore ISO mounting pad with actuator

5320912-008**	5324010	163	124	169	104	1/4"
5320912-010**	5324010	163	124	169	104	3/8"
5320912-015**	5324010	163	124	169	104	1/2"
5320912-020*	5324020	210,5	169	181	110	3/4"
5320912-025*	5324020	216	169	181	110	1"
5320912-032*	5324035	221	169	181	110	1 1/4"
5320912-040*	5324035	231	169	181	110	1 1/2"
5320912-050*	5324055	267	196	181	110	2"
5320912-065*	5324055	285	196	181	110	2 1/2"
5320912-080*	5324085	294	196	181	128	3"
5320912-100*	5324140	-	-	-	-	4"

- *12V VAC/VDC **24V VAC/VDC

0912
5300912
 ACTUADOR ELÉCTRICO ALTO VOLTAJE
 ELECTRIC ACTUATOR HIGH VOLTAGE



Válvula tres piezas roscar paso total con pletina ISO y actuador

Three pieces ball valve threaded full bore ISO mounting pad with actuator

5300912-008**	5300010	163	124	169	104	1/4"
5300912-010**	5300010	163	124	169	104	3/8"
5300912-015**	5300010	163	124	169	104	1/2"
5300912-020*	5300020	210,5	169	181	110	3/4"
5300912-025*	5300020	216	169	181	110	1"
5300912-032*	5300035	221	169	181	110	1 1/4"
5300912-040*	5300035	231	169	181	110	1 1/2"
5300912-050*	5300055	267	196	181	110	2"
5300912-065*	5300055	285	196	181	110	2 1/2"
5300912-080*	5300085	294	196	181	128	3"
5300912-100*	5300140	-	-	-	-	4"

- *24V-240V VAC/VDC ** 85V VAC/VDC

Para temperaturas superiores a 70°C se debe montar un puente separador entre la válvula y el actuador.
 At temperatures above 70°C separating bridge must be mounted between the valve and the actuator.

CÓDIGO CODE
 ACTUADOR ACTUATOR
H ALTURA DESDE EJE DE VÁLVULA A PARTE SUPERIOR DEL ACTUADOR
 HIGH FROM VALVE AXIS TO ACTUATOR TOP
F ALTURA DEL ACTUADOR ACTUATOR HIGH
A LONGITUD DEL ACTUADOR ACTUATOR LENGTH
G GROSOR DEL ACTUADOR ACTUATOR THICKNESS
 MEDIDA SIZE

91031
51091031
 SIMPLE EFECTO
 SIMPLE RETURN
 ACTUATOR



Válvula esfera tipo wafer
 paso total con pletina ISO
 con actuador
 Ball valve wafer-type with
 ISO mounting pad and
 actuator



51091031-015	5100052	139	92	145	71	1/2"
51091031-020	5100052	146	92	145	71	3/4"
51091031-025	5100075	180	120	201	94	1"
51091031-032	5100075	192	120	201	94	1 1/4"
51091031-040	5100083	206	128	209	101	1 1/2"
51091031-050	5100092	225	140	242	108,5	2"
51091031-065	5100105	258	153	275	122	2 1/2"
51091031-080	5100125	290	175	332	137,5	3"
51091031-100	5100140	313,5	191,5	385	153	4"

- Actuadores neumáticos ATEX
Pneumatic actuators ATEX
- Los actuadores neumáticos están calculados en base a una presión de aire de entrada de 6 Bares
Pneumatic actuators are calculated based on an inlet air pressure of 6 Bar

91031
52091031
 DOBLE EFECTO
 DOUBLE ACTING
 ACTUATOR



Válvula esfera tipo wafer
 paso total con pletina ISO
 con actuador
 Ball valve wafer-type with
 ISO mounting pad and
 actuator



52091031-015	5200052	139	92	145	71	1/2"
52091031-020	5200052	146	92	145	71	3/4"
52091031-025	5200052	152	92	145	71	1"
52091031-032	5200052	164	92	145	71	1 1/4"
52091031-040	5200063	186	108	169	82	1 1/2"
52091031-050	5200063	193	108	169	82	2"
52091031-065	5200075	225	120	201	94	2 1/2"
52091031-080	5200083	243	128	209	101	3"
52091031-100	5200105	275	153	275	122	4"

- Actuadores neumáticos ATEX
Pneumatic actuators ATEX
- Los actuadores neumáticos están calculados en base a una presión de aire de entrada de 6 Bares
Pneumatic actuators are calculated based on an inlet air pressure of 6 Bar

91031
53291031
 ACTUADOR
 ELÉCTRICO
 BAJO VOLTAJE
 ELECTRIC
 ACTUATOR
 LOW VOLTAGE



Válvula esfera tipo wafer
 paso total con pletina ISO
 con actuador
 Ball valve wafer-type with
 ISO mounting pad and
 actuator

53291031-015	5324020	216	169	181	110	1/2"
53291031-020	5324020	223	169	181	110	3/4"
53291031-025	5324020	229	169	181	110	1"
53291031-032	5324020	241	169	181	110	1 1/4"
53291031-040	5324035	247	169	181	110	1 1/2"
53291031-050	5324035	254	169	181	110	2"
53291031-065	5324055	301	196	181	110	2 1/2"
53291031-080	5324085	311	196	181	128	3"
53291031-100	5324140	376	254	235	214	4"

- 12V VAC/VDC

91031
53091031
 ACTUADOR
 ELÉCTRICO
 ALTO VOLTAJE
 ELECTRIC
 ACTUATOR
 HIGH VOLTAGE



Válvula esfera tipo wafer
 paso total con pletina ISO
 con actuador
 Ball valve wafer-type with
 ISO mounting pad and
 actuator

53091031-015	5300020	216	169	181	110	1/2"
53091031-020	5300020	223	169	181	110	3/4"
53091031-025	5300020	229	169	181	110	1"
53091031-032	5300020	241	169	181	110	1 1/4"
53091031-040	5300035	247	169	181	110	1 1/2"
53091031-050	5300035	254	169	181	110	2"
53091031-065	5300055	301	196	181	110	2 1/2"
53091031-080	5300085	311	196	181	128	3"
53091031-100	5300140	376	254	235	214	4"

- 24V-240V VAC/VDC

Para temperaturas superiores a 70°C se debe montar un puente separador entre la válvula y el actuador.
 At temperatures above 70°C separating bridge must be mounted between the valve and the actuator.

CÓDIGO CODE
 ACTUADOR ACTUATOR
 H ALTURA DESDE EJE DE VÁLVULA A PARTE SUPERIOR DEL ACTUADOR
 HIGH FROM VALVE AXIS TO ACTUATOR TOP
 F ALTURA DEL ACTUADOR ACTUATOR HIGH
 A LONGITUD DEL ACTUADOR ACTUATOR LENGTH
 G GROSOR DEL ACTUADOR ACTUATOR THICKNESS
 MEDIDA SIZE

91032
51091032
 SIMPLE EFECTO
 SIMPLE RETURN
 ACTUATOR



Válvula esfera tipo wafer con pletina ISO, camisa y actuador
 Ball valve wafer-type with ISO mounting pad, heating chamber and actuator



51091032-015	5100052	139	92	145	71	1/2"
51091032-020	5100052	146	92	145	71	3/4"
51091032-025	5100075	180	120	201	94	1"
51091032-032	5100075	192	120	201	94	1 1/4"
51091032-040	5100083	206	128	209	101	1 1/2"
51091032-050	5100092	225	140	242	108,5	2"
51091032-065	5100105	258	153	275	122	2 1/2"
51091032-080	5100125	290	175	332	137,5	3"
51091032-100	5100140	313,5	191,5	385	153	4"

• Actuadores neumáticos ATEX
 Pneumatic actuators ATEX

• Los actuadores neumáticos están calculados en base a una presión de aire de entrada de 6 Bares
 Pneumatic actuators are calculated based on an inlet air pressure of 6 Bar

91032
52091032
 DOBLE EFECTO
 DOUBLE ACTING
 ACTUATOR



Válvula esfera tipo wafer con pletina ISO, camisa y actuador
 Ball valve wafer-type with ISO mounting pad, heating chamber and actuator



52091032-015	5200052	139	92	145	71	1/2"
52091032-020	5200052	146	92	145	71	3/4"
52091032-025	5200052	152	92	145	71	1"
52091032-032	5200052	164	92	145	71	1 1/4"
52091032-040	5200063	186	108	169	82	1 1/2"
52091032-050	5200063	193	108	169	82	2"
52091032-065	5200075	225	120	201	94	2 1/2"
52091032-080	5200083	243	128	209	101	3"
52091032-100	5200105	275	153	275	122	4"

• Actuadores neumáticos ATEX
 Pneumatic actuators ATEX

• Los actuadores neumáticos están calculados en base a una presión de aire de entrada de 6 Bares
 Pneumatic actuators are calculated based on an inlet air pressure of 6 Bar

91032
53291032
 ACTUADOR
 ELÉCTRICO
 BAJO VOLTAJE
 ELECTRIC
 ACTUATOR
 LOW VOLTAGE



Válvula esfera tipo wafer con pletina ISO, camisa y actuador
 Ball valve wafer-type with ISO mounting pad, heating chamber and actuator

53291032-015	5324020	216	169	181	110	1/2"
53291032-020	5324020	223	169	181	110	3/4"
53291032-025	5324020	229	169	181	110	1"
53291032-032	5324020	241	169	181	110	1 1/4"
53291032-040	5324035	247	169	181	110	1 1/2"
53291032-050	5324035	254	169	181	110	2"
53291032-065	5324055	301	196	181	110	2 1/2"
53291032-080	5324085	311	196	181	128	3"
53291032-100	5324140	376	254	235	214	4"

• 12V VAC/VDC

91032
53091032
 ACTUADOR
 ELÉCTRICO
 ALTO VOLTAJE
 ELECTRIC
 ACTUATOR
 HIGH VOLTAGE



Válvula esfera tipo wafer con pletina ISO, camisa y actuador
 Ball valve wafer-type with ISO mounting pad, heating chamber and actuator

53091032-015	5300020	216	169	181	110	1/2"
53091032-020	5300020	223	169	181	110	3/4"
53091032-025	5300020	229	169	181	110	1"
53091032-032	5300020	241	169	181	110	1 1/4"
53091032-040	5300035	247	169	181	110	1 1/2"
53091032-050	5300035	254	169	181	110	2"
53091032-065	5300055	301	196	181	110	2 1/2"
53091032-080	5300085	311	196	181	128	3"
53091032-100	5300140	376	254	235	214	4"

• 24V-240V VAC/VDC

Para temperaturas superiores a 70°C se debe montar un puente separador entre la válvula y el actuador.
 At temperatures above 70°C separating bridge must be mounted between the valve and the actuator.

5

INSTRUMENTOS DE MEDICIÓN

MEASUREMENT TOOLS



CARACTERÍSTICAS

Acorde con EN837-1
Escala de medida positiva y dual, unidades: BAR/PSI
Manómetro analógico
Rosca 1/2" BSP macho

FEATURES

Following EN837-1
Positive and Dual Scale
units: BAR/PSI
Analog manometers
Thread 1/2" BSP male

Producto 8799
Manómetro acero
inoxidable glicerina
DN63 conexión inferior
inoxidable 1/4"

Product 8799
Stainless steel glycerine
filled pressure gauge DN63
stainless steel bottom
connection 1/4"

LÍMITES TÉCNICOS

Temperatura ambiente: de -20°C a +60°C
Temperatura de proceso: hasta +60°C
Se recomienda que la presión de trabajo sea inferior al 75% del rango total para presiones sostenidas y 65% para presiones fluctuantes.

TECHNICAL LIMITS

Ambient Temperature: from -20°C to +60°C
Process Temperature: until +60°C
Recommended maximum working pressure must be less than 75% of the total range for sustained pressure and 65% for fluctuating pressures.

CÓDIGO CODE _____
 BAR BAR _____
 DIAL (BAR) DIAL (BAR) _____
 ENCAJADO GRANDE MASTER CARTON _____
 ENCAJADO INTERMEDIO INNER CARTON _____

8400



Manómetro esfera seca
DN50 conexión posterior
latón 1/4"

Dry sphere pressure gauge
DN50 brass back connec-
tion 1/4"

EAN CODE

8400-02	0-2,5	0.1	60	1
8400-04	0-4	0.1	60	1
8400-06	0-6	0.1	60	1
8400-10	0-10	0.2	60	1
8400-16	0-16	0.2	60	1

• Rango de precisión: ± 1,6%
Precision range: ± 1,6%



FICHA TÉCNICA
TECHNICAL SHEET

8500



Manómetro esfera seca
DN50 conexión inferior
latón 1/4"

Dry sphere pressure
gauge DN50 brass bottom
connection 1/4"

EAN CODE

8500-02	0-2,5	0.1	72	1
8500-04	0-4	0.1	72	1
8500-06	0-6	0.1	72	1
8500-10	0-10	0.2	72	1
8500-16	0-16	0.2	72	1

• Rango de precisión: ± 1,6%
Precision range: ± 1,6%



FICHA TÉCNICA
TECHNICAL SHEET

8599



Manómetro acero
inoxidable glicerina DN63
conexión inferior latón 1/4"

Stainless steel glycerine
filled pressure gauge DN63
brass bottom connection
1/4"

EAN CODE

8599-02	0-2,5	0.05	54	1
8599-04	0-4	0.1	54	1
8599-06	0-6	0.1	54	1
8599-10	0-10	0.2	54	1
8599-16	0-16	0.2	54	1
8599-25	0-25	0.5	54	1
8599-40	0-40	1.0	54	1
8599-60	0-60	1.0	54	1
8599-100	0-100	2.0	54	1

• Rango de precisión: ± 1,6%
Precision range: ± 1,6%



FICHA TÉCNICA
TECHNICAL SHEET

8799



Manómetro acero
inoxidable glicerina DN63
conexión inferior inoxida-
ble 1/4"

Stainless steel glycerine
filled pressure gauge DN63
stainless steel bottom
connection 1/4"

EAN CODE INOX

8799-02	0-2,5	0.1	54	1
8799-04	0-4	0.1	54	1
8799-06	0-6	0.1	54	1
8799-10	0-10	0.2	54	1
8799-16	0-16	0.2	54	1
8799-25	0-25	1.0	54	1
8799-40	0-40	2.0	54	1
8799-60	0-60	2.0	54	1
8799-100	0-100	5.0	54	1

• Rango de precisión: ± 1,6%
Precision range: ± 1,6%



FICHA TÉCNICA
TECHNICAL SHEET

CÓDIGO CODE _____
 BAR BAR _____
 DIAL (BAR) DIAL (BAR) _____
 ENCAJADO GRANDE MASTER CARTON _____
 ENCAJADO INTERMEDIO INNER CARTON _____

8600



Manómetro acero
 inoxidable glicerina
 DN100 conexión inferior
 latón 1/2"

Stainless steel glycerine
 filled pressure gauge
 DN100 brass bottom
 connection 1/2"

EAN CODE **INOX**

8600-06	0-6	0.1	16	1
8600-10	0-10	0.2	16	1
8600-16	0-16	0.2	16	1
8600-40	0-40	1.0	16	1
8600-100	0-100	2.0	16	1

- Rango de precisión: ± 1,6%
Precision range: ± 1,6%
- Caja acero inoxidable
Stainless steel case



FICHA TÉCNICA
TECHNICAL SHEET

8800



Manómetro acero
 inoxidable glicerina
 DN100 conexión inferior
 inoxidable 1/2"

Stainless steel glycerine
 filled pressure gauge
 DN100 stainless steel
 bottom connection 1/2"

EAN CODE **INOX**

8800-06	0-6	0.1	16	1
8800-10	0-10	0.2	16	1
8800-16	0-16	0.2	16	1
8800-40	0-40	1.0	16	1
8800-100	0-100	2.0	16	1

- Rango de precisión: ± 1,6%
Precision range: ± 1,6%
- Caja acero inoxidable
Stainless steel case



FICHA TÉCNICA
TECHNICAL SHEET

9

RECAMBIOS

SPARE PARTS



Maneta ergonómica en
acero inoxidable con
tuerca autoblocante
Ergonomic stainless
steel handle with
self-locking nut

Producto 494081
Maneta acero inoxidable
para válvula PN-30

Product 494081
Stainless steel handle for
PN-30 ball valve

SERIE PLATINUM PLATINUM SERIES

CÓDIGO CODE	_____	_____	_____
MEDIDA SIZE	_____	_____	_____
ENCAJADO GRANDE MASTER CARTON	_____		
ENCAJADO INTERMEDIO INNER CARTON	_____		

494081



Recambio - Maneta acero inoxidable color negro para válvula PN-40

PLATINUM

Spare part - Stainless steel black handle for PN-40 ball valve

494081-1520	1/2"	240	1
	3/4"	240	1
494081-0025	1"	120	1
494081-0032	1 1/4"	80	1
494081-0040	1 1/2"	120	1
494081-0050	2"	120	1

VÁLVULAS DE MARIPOSA BUTTERFLY VALVES

CÓDIGO CODE	_____	_____	_____
MEDIDA SIZE	_____	_____	_____
ENCAJADO GRANDE MASTER CARTON	_____		

51224



Recambio - Reductor manual para las válvulas de mariposa

Spare part - Hand wheel gear box for butterfly valves

51224-040100	1 1/2" - 4"		1
51224-125150	5" - 6"		1
51224-200	8"		1
51224-250	10"		1
51224-300	12"		1

VÁLVULA COMPUERTA CIERRE ELÁSTICO RESILIENT WEDGE GATE VALVE

CÓDIGO CODE	_____	_____	_____
MEDIDA SIZE	_____	_____	_____
ENCAJADO GRANDE MASTER CARTON	_____		

5123



Recambio - Cuadradillo para 5113

Spare part - Square handle for 5113

5123-040080M	DN40 - DN80		1
5123-100125M	DN100 - DN125		1
5123-150250M	DN150 - DN250		1
5123-300350M	DN300 - DN350		1

5135



Recambio - Volante para 5143

Spare part - Handwheel for 5143

5135	3/4" - 2"		1
------	-----------	--	---

- El volante es una opción, no se adjunta con la 5143
Handwheel is an option, it is not included with 5143

MANGUITOS ELÁSTICOS EXPANSION JOINS

CÓDIGO CODE	_____
MEDIDA SIZE	_____
ENCAJADO GRANDE MASTER CARTON	_____

5126



Recambio - Pasador para manguitos elásticos simple onda

Spare part - Control rod set elastic joints single sphere

5126-100	4"	1
5126-125	5"	1
5126-150	6"	1
5126-200	8"	1
5126-250	10"	1
5126-300	12"	1

- Compuesto por: dos soportes triángulo, dos varillas roscada, dos tuercas, dos arandelas y dos juntas planas
Kit: two triangle supports, two threaded rods, two nuts, two washers and two flat gaskets.



FICHA TÉCNICA
TECHNICAL SHEET

MT PRESS MT PRESS

JE

Recambio - Junta EPDM

Spare part - O-ring EPDM

DVGW



CÓDIGO CODE	MEDIDA SIZE	📦	📦
JE015	15	5000	500
JE018	18	5000	500
JE022	22	3000	300
JE028	28	3000	300
JE035	35	3000	300
JE042	42	2000	200
JE054	54	2000	200
JE076	76	150	15
JE088	88	150	15
JE108	108	150	15

JV

Recambio - Junta FKM

Spare part - O-ring FKM

DVGW



CÓDIGO CODE	MEDIDA SIZE	📦	📦
JV015	15	5000	500
JV018	18	5000	500
JV022	22	3000	300
JV028	28	3000	300
JV035	35	3000	300
JV042	42	2000	200
JV054	54	2000	200
JV076	76	150	15
JV088	88	150	15
JV108	108	150	15

CONDICIONES DE VENTA

SALES CONDITIONS

CONDICIONES VÁLIDAS SÓLO PARA ESPAÑA

VALID CONDITIONS ONLY IN SPAIN

PRECIOS Y CONDICIONES DE PAGO

Contado: reposición o recibo a 15 días dto. P.P. 1%.

Forma de pago: plazo máximo 60 días fecha factura.

IVA: se cargará el % correspondiente, según reglamentación en vigor.

Tarifas de precios: nos comprometemos a comunicar a nuestros clientes cualquier cambio que se produzca en las tarifas del catálogo a través de las usuales vías de comunicación: web, email, correo.

PEDIDOS

Con el fin de evitar confusiones y ofrecer un mejor servicio, será condición indispensable por parte del comprador indicar la referencia MT Business Key, S.L. en su pedido, incluidos los dígitos de la medida. Cada pedido enviado a MT Business Key, S.L. genera una expedición para el cliente, recomendamos que preparen sus pedidos completos para optimizar los gastos de transporte. Todos los pedidos serán confirmados vía email y, salvo notificación de lo contrario, seguirá su curso sin derecho a posteriores modificaciones.

Pedido mínimo aceptable: 150€ netos.

Cantidades mínimas: las cantidades mínimas aceptables corresponderán a las del embalaje interior de la caja.

Embalajes: incluidos.

PORTES

Se cargarán 7€ en factura para pedidos inferiores a los 400 € netos (Península y Baleares). Para el resto del territorio se cargarán los portes en factura aplicando la tarifa reducida de nuestra agencia de transportes.

España (Península) e Islas Baleares: incluidos en pedidos superiores a 400€ netos.

Melilla: incluidos en pedidos superiores a 1200€ netos.

Islas Canarias: incluidos en pedidos superiores a 800€ netos.

SERVICIOS POSTVENTA OFRECIDOS POR MT:

Reclamaciones: cualquier reclamación deberá formularse dentro de los treinta (30) días siguientes a la fecha de factura, rechazándose las efectuadas después de dicho plazo límite.

Periodo de desistimiento: conforme la Ley General para la Defensa de los Consumidores y Usuarios, el comprador dispone de catorce (14) días naturales para devolver la totalidad o parte del pedido sin penalización alguna, a contar desde la fecha de factura.

Devoluciones: no se aceptará ninguna devolución de material sin antes existir la conformidad expresa, mediante el número de devolución facilitado, por la empresa (véase nuestra política y proceso de devolución en la web). El plazo máximo admitido para devolver material no conforme es de sesenta (60) días, a contar desde la fecha de factura.

Garantía: todos nuestros productos tienen 2 años de garantía según establece la Ley vigente. Si el defecto se manifiesta pasados los 6 meses después de su compra se requerirá una revisión técnica y/o pericial por nuestro departamento de calidad con tal de poder aplicar su derecho a la garantía.

La garantía queda limitada pura y simplemente al reemplazo de las piezas, una vez reconocidas materialmente defectuosas por nuestro personal técnico sin indemnización.

Litigios: en caso de litigio ambas partes aceptan someter sus diferencias a los juzgados y tribunales de Barcelona.

MT Business Key S.L. se reserva la facultad de cambiar en todo o en parte el diseño, materiales, embolsado, encajado y precios de cualquiera de sus productos.

CONDICIONES VÁLIDAS SÓLO PARA EXPORTACIÓN

VALID CONDITIONS ONLY FOR EXPORT

RATES AND FREIGHTS CONDITIONS

Cash: bank transfer. For advance payments discount 1%.

Credit: max. 60 days invoice date after Bank Insurance Approval.

Freight Conditions: EXW Incoterms 2010, unless other conditions are granted.

Price rates: MT Business Key, S.L. commits to communicate to our customers any changes applied on tariffs through usual means of communication: web & email.

ORDERS

Minimum order amount: 500€ netto.

Minimum quantities: the minimum acceptable quantities will be equal to inner packing quantities.

Packing: included.

CUSTOMER SERVICE

Claims: all claims will be granted within 45 days after date of Invoice. After this period MT Business Key, S.L. can't promise any resolution.

Warranty: all our products are new and are covered for 2 years.

Return policy: all material returned will be at freight paid. All products must be in original conditions and clearly identified. If after inspection in our warehouse these products are not in original condition, we might apply a devaluation fee.

CONDITIONS INSIDE EU:

Even though all purchases are covered by our extended 14-day exchange or refund promise, no material return will be accepted without the conformity of the commercial department.

No unwanted material returned will be accepted after 60 days invoice's date. All unwanted material returned after 14 days of date of invoice and before maximum period of acceptance (60 days) will be charged 30% of demerit.

CONDITIONS OUTSIDE EU:

No unwanted material returned will be accepted after 90 days Invoice's date. All unwanted material returned will be charged 30% of demerit.

Litigations: in case of litigation both sides agree to take their differences at the courts of Barcelona.

MT Business Key S.L. reserves the right to modify all or part of the design, materials, packing or prices of any of their products.



Nuevo servicio urgente 24 horas sólo para España

Para paquetería de menos de 10 kg. 7 € en factura.

Para expediciones de menos de 30 kg. 12 € en factura.

Para pedidos superiores a 30 kg de peso, consultar.

New urgent service 24 hours only in Spain

For packages of less than 10 kg. 7 € in invoice

For expeditions of less than 30 kg. 12 € in invoice

For higher orders to 30 kg weight, consult.

ANEXO

ANNEX

DICCIONARIO TÉCNICO FORMACIÓN BÁSICA DE CONCEPTOS Y PRODUCTOS

CONCEPTOS

DN

Abreviación de Diámetro Nominal. Indica el diámetro interior de paso del fluido por dentro de tuberías, válvulas o accesorios.

PN

Abreviación de Presión Nominal. Indica la presión interior máxima de trabajo en condiciones de temperatura ambiente y presión exterior atmosférica. El límite de presión de trabajo es una curva que va decreciendo en función del aumento de temperatura. La correcta aplicación de una válvula se realiza primero con la determinación de las condiciones de temperatura y presión y su comprobación de que el punto de trabajo siga dentro de las condiciones mecánicas de funcionamiento de esta.

PÉRDIDA DE CARGA

Disminución de la energía dinámica del fluido producido por la fricción con las paredes, su propia fricción entre sus partículas. Los cambios bruscos de dirección o de diámetro aumentan las pérdidas de carga de manera significativa.

GOLPE DE ARIETE

Fenómeno de aumento excesivo de la presión producido en las instalaciones hidráulicas cuando hay un cierre brusco del caudal del fluido. Es un fenómeno peligroso pues las presiones pueden aumentar muy por encima de las presiones nominales de los componentes y producir roturas en tuberías, accesorios y/o válvulas.

La forma de evitar estos golpes de ariete es ralentizar el cierre de las válvulas o instalar algún mecanismo que pueda absorber el exceso de presión (Vasos de expansión, dispositivos antiariete como el de MT modelo 4160).

PASO TOTAL

Una válvula se puede considerar de Paso Total o Paso Completo cuando el paso del fluido es igual a su DN (Diámetro nominal). Según UNE-EN-13828.

PASO REDUCIDO

Una válvula se puede considerar de Paso Reducido cuando el paso del fluido es una medida inferior a su DN (diámetro nominal). Según UNE-EN-13828.

ESTANQUEIDAD

Concepto que nos indica que no pasa fluido a través de la válvula en posición de cierre ni por cualquier otro punto (eje, unión cuerpo-tapa, etc).

PAR DE GIRO

Fuerza medida en Nm que se ejerce para la apertura y cierre de la válvula. Es importante su valor para poder dimensionar correctamente un actuador. Las condiciones de trabajo, presión, temperatura, presión diferencial, densidad del fluido y viscosidad del fluido puede modificar significativamente el par de giro por lo que como mínimo se debe de tener un margen de seguridad del 30%.

TECHNICAL DICTIONARY BASIC TRAINING OF CONCEPTS AND PRODUCTS

CONCEPTS

DN

Abbreviation of Nominal Diameter. Indicates the internal diameter of fluid passage through pipes, valves or fittings.

PN

Abbreviation of Nominal Pressure. Indicates the maximum internal working pressure under ambient temperature and atmospheric external pressure. The working pressure limit is a curve that decreases depending on the temperature increase. The correct application of a valve is first carried out with the determination of the temperature and pressure conditions and its verification that the working point remains within its mechanical operating conditions.

HEAD LOSS

Reduction of the dynamic energy of the fluid produced by friction with the walls, its own friction between its particles. Sudden changes in direction or diameter increase load losses significantly.

WATER HAMMER

Phenomenon of excessive increase of the pressure produced in the hydraulic installations when there is an abrupt closure of the fluid flow. It is a dangerous phenomenon because the pressures can increase well above the nominal pressures of the components and cause breaks in pipes, fittings and / or valves.

The way to avoid these water hammers is to slow down the closing of the valves or install some mechanism that can absorb excess pressure (expansion vessels, anti-cracking devices such as MT model 4160).

FULL BORE

A valve can be considered as Total Pass or Full Pass when the fluid flow is equal than its DN (Nominal Diameter). According to UNE-EN-13828.

REDUCED BORE

A valve can be considered a Reduced Pass when the fluid flow is one size smaller than its DN (Nominal Diameter). According to UNE-EN-13828.

SEALING

Concept that indicates that no fluid passes through the valve in the closed position or any other point (stem, body-cover joint, etc).

TORQUE

Force measured in Nm used to open or closing the valve. Its value is important in order to determinate the correct size for actuator. The working conditions, pressure, temperature, differential pressure, fluid density and fluid viscosity can significantly change the torque so that at least a safety margin of 30% must be had.

MATERIALES

HIERRO

Metal común frágil y con poca resistencia de la dureza y oxidación. En nuestro caso, lo galvanizamos (tratamiento químico), para darle una mayor resistencia a la oxidación.

LATÓN

El latón es una aleación de Cobre y Zinc. Muy usado en valvulería para edificación por su facilidad de manipulación combinada a su características mecánicas y su resistencia a la oxidación.

Propiedades:

- Buena resistencia a la oxidación.
- Excelente mecanización en frío.
- Excelente capacidad de recubrirse, como niquelados, galvanizados y cromados
- Excelente soldabilidad.

Existen diferentes tipos de latones, las normas que los definen son la EN-12164, EN-12165. La tendencia actual en Europa es la de cambiar a latones tipo DZR con mayores propiedades oxidantes y latones con menores o nulas cantidades de plomo.

ACERO INOXIDABLE

Los productos de MT utilizan básicamente dos tipos de Aceros Inoxidable. Se usan para válvulas que la exigencia mecánica alta, y el fluido y ambiente son corrosivos.

A304, A304L: Acero Inoxidable Austenítico con unas buenas propiedades oxidante.

A316, A316L: Acero Inoxidable Austenítico con unas mejores propiedades oxidante que el A304 por la adición de Molibdeno.

Propiedades:

- Excelente resistencia a la oxidación.
- Buena mecanización en frío.
- Buena soldabilidad en las versiones "L" de bajo contenido en carbono (A304L y A316L)
- Muy buenas propiedades mecánicas. Gran tenacidad.

Las condiciones mecánicas de estos aceros pueden variar según la forma de enfriamiento y por los tratamientos térmicos. La norma EN-10088 los describe.

FUNDICIÓN GRIS

Aleación de hierro, carbono y otros elementos en menores cantidades. Se usa para válvulas que la exigencia mecánica no sea grande, y el fluido y ambiente no son corrosivos.

Propiedades:

- Baja resistencia a la oxidación.
- Baja dureza.
- Fragilidad media.
- Buenas propiedades mecánicas.
- Excelente mecanización en frío.

Las válvulas de fundición gris van recubiertas por pinturas epoxi para mejorar notablemente su resistencia a la oxidación.

FUNDICIÓN NODULAR O DÚCTIL

Aleación de hierro, carbono y otros elementos en menores cantidades. Aumento de la Dureza y la resistencia a la fatiga.

Se usa para válvulas que la exigencia mecánica es medias, y el fluido y ambiente no son corrosivos.

Propiedades:

- Baja resistencia a la oxidación.
- Mejora la dureza de la fundición gris.
- Mejora la fragilidad de la fundición gris.
- Buenas propiedades mecánicas, mejores que la fundición gris.
- Excelente mecanización en frío.

Las válvulas de fundición dúctil también van recubiertas por pinturas epoxi para mejorar notablemente su resistencia a la oxidación.

ACERO AL CARBONO

Aleación de hierro con carbono. A diferencia de los aceros inoxidable tiene pocos elementos aleados. Son el tipo de aceros más producidos a nivel mundial.

Se usa para válvulas que necesitan unas propiedades mecánicas exigentes.

Propiedades:

- Baja resistencia a la oxidación.
- Mejora la dureza de la fundición gris.
- Mejora la fragilidad de la fundición gris.
- Buenas propiedades mecánicas, mejores que la fundición gris.
- Buena mecanización en frío.

Las válvulas de acero al carbono suelen protegerse con aceites y algunas con pintura epoxi para aumentar su resistencia a la oxidación.

NBR

Caucho de Nitrilo Butadieno (**N**itrile **B**utadiene **R**ubber). Elastómero procedente de caucho.

Propiedades:

- Compatible con hidrocarburos, petróleo y gasóleos.
- Compatible con agua para suministro humano.
- Las temperaturas de utilización van de los -20°C a los 80°C
- Gran resistencia a las deformaciones.
- Buena resistencia a la abrasión.

Algunas válvulas lo usan para sellar el eje en forma de junta tórica o en junta plana.

EPDM

Etileno Propileno Dieno tipo **M**, elastómero sintético.

Propiedades:

- No es compatible con hidrocarburos, petróleo y gasóleos.
- Compatible con agua para suministro humano.
- Las temperaturas de utilización van de los -20°C a los 120°C.
- Gran resistencia a las deformaciones.
- Buena resistencia a la abrasión.

Algunas válvulas lo usan para sellar el eje en forma de junta tórica o en junta plana.

FKM

Elastómero fluoropolímero.

Propiedades:

- Compatible con hidrocarburos, petróleo y gasóleos.
- Compatible con agua para suministro humano.
- Las temperaturas de utilización van de los -20°C a los 180°C.
- Gran resistencia a las deformaciones.
- Buena resistencia a altas temperaturas.
- Se puede usar como cierre para válvulas en instalaciones de solar térmica.

Algunas válvulas lo usan para sellar el eje en forma de junta tórica o en junta plana.

PTFE

Elastómero sintético, **p**olitetrafluoretileno.

Propiedades:

- Compatible con la mayoría de químicos.
- Compatible con agua para suministro humano.
- Las temperaturas de utilización va de los -270°C a los 280°C
- Buena resistencia a temperaturas cercanas al cero absoluto y a altas temperaturas.
- Es el material con el menor coeficiente de fricción conocido.
- Se puede usar como cierre para válvulas en instalaciones de solar térmica.
- Fácil mecanización.
- Se puede mezclar con grafito o fibra de vidrio para mejorar sus propiedades mecánicas.

Algunas válvulas lo usan para sellar el eje en forma de junta plana.

MATERIALS

IRON

Common metal fragile and with little resistance to hardness and oxidation. In our case, we galvanize it (chemical treatment), to give it greater resistance to oxidation.

BRASS

Brass is an alloy of Copper and Zinc. Widely used in building valves for ease handling combined with its mechanical properties and oxidation resistance.

Properties:

- Good oxidation resistance.
- Excellent cold machining.
- Excellent coating ability, such as nickel plated, galvanized and chrome plated.
- Excellent weldability.

There are different types of brass, the standards defining them are EN-12164, EN-12165. The current trends in Europe are to switch to brass type DZR with higher oxidizing properties and brass with less or no lead content.

STAINLESS STEEL

MT products use basically two types of stainless steels. They are used for valves with high mechanical requirements, and the fluid and environment are corrosive.

A304, A304L: Austenitic Stainless Steel with good oxidizing properties.

A316, A316L: Austenitic Stainless Steel with better oxidizing properties than A304 by the addition of Molybdenum.

Properties:

- Excellent resistance to oxidation.
- Good cold machining.
- Good weldability in low carbon "L" versions (A304L and A316L)
- Very good mechanical properties. Great tenacity.

The mechanical conditions of these steels may vary depending on the form of cooling and the heat treatment. The standard EN-10088 describes them.

CAST IRON

Alloying of iron, carbon and other elements in smaller quantities.

It's used for valves where the mechanical requirement is not large and the fluid and environment are not corrosive. Properties:

- Low resistance to oxidation.
- Low hardness.
- Medium fragility.
- Good mechanical properties.
- Excellent cold machining.

Cast iron valves are coated with epoxy paint to significantly improve their resistance to oxidation.

NODULAR OR DUCTILE IRON

Alloying of iron, carbon and other elements in smaller quantities. Increased hardness and fatigue resistance than cast iron.

It is used for valves whose mechanical requirements are average, and the fluid and environment are not corrosive.

Properties:

- Low resistance to oxidation.
- Improves the hardness of the gray foundry.
- Improves the fragility of the gray foundry.
- Good mechanical properties, better than the gray foundry.
- Excellent cold machining.

Ductile iron valves are also coated with epoxy paints to significantly improve their oxidation resistance.

CARBON STEEL

Iron alloy with carbon. Unlike stainless steels it has few alloyed elements. They are the most produced type of steels in the world.

It is used for valves that require demanding mechanical properties.

Properties:

- Low resistance to oxidation.
- Improves the hardness of the gray foundry.
- Improves the fragility of the gray foundry.
- Good mechanical properties, better than the gray foundry.
- Good cold machining.

Carbon steel valves are usually protected with oils and some with epoxy paint to increase their resistance to oxidation.

NBR

Nitrile **B**utadiene **R**ubber. Elastomer from rubber.

Properties:

- Compatible with hydrocarbons, oil and diesel.
 - Compatible with water for human supply.
 - The operating temperatures range from -20°C to 80°C.
 - High resistance to deformations.
 - Good abrasion resistance.
- Some valves use it to seal the shaft in the form of a O-ring or a flat joint.

EPDM

Ethylene **P**ropylene **D**iene type **M**, synthetic elastomer.

Properties:

- Not compatible with hydrocarbons, oil and gas.
 - Compatible with water for human supply.
 - The operating temperatures range from -20°C to 120°C.
 - High resistance to deformations.
 - Good abrasion resistance.
- Some valves use it to seal the shaft in the form of a O-ring or a flat joint.

FKM

Fluoropolymer elastomer.

Properties:

- Compatible with hydrocarbons, oil and diesel.
 - Compatible with water for human supply.
 - Use temperatures range from -20°C to 180°C.
 - High resistance to deformations.
 - Good resistance to high temperatures.
- Can be used as a shutoff for valves in solar thermal installations.
- Some valves use it to seal the shaft in the form of a O-ring or a flat joint.

PTFE

Synthetic elastomer, **polytetrafluoroethylene**.

Properties:

- Compatible with most chemicals.
 - Compatible with water for human supply.
 - The operating temperatures range from -270°C to 280°C.
 - Good resistance to temperatures close to absolute zero and high temperatures.
 - It's the material with the lowest known coefficient of friction.
 - Can be used as a valve closure in solar thermal installations.
 - Easy machining.
 - Can be mixed with graphite or fiberglass to improve its mechanical properties.
- Some valves use it to seal the shaft in the form of a flat joint.

COMPUESTO QUÍMICO	FORRO INTERIOR DE LA JUNTA DE EXPANSIÓN			
	NBR	EPDM	FKM	PTFE
	NITRIL	EPDM	VITON	TEFLÓN
Acete hidráulico (petróleo)	A	X	A	A
Acete de linaza	A	B	A	A
Acete de oliva	A	C	A	A
Acetes de petróleo con alto contenido aromático	B	X	A	A
Acetes de petróleo con bajo contenido aromático	A	X	A	A
Acete de resina	A	X	A	A
Acete lubricación	A	X	A	A
Acete para transformadores	X	X	A	A
Acete para transformadores de base mineral	A	X	A	A
Acetes vegetales	A	X	A	A
Acetaldehido D	X	B	A	A
Acetato	X	A	X	A
Acetato de butilo	X	B	X	A
Acetato de etilo	X	B	X	A
Acetileno	A	A	A	A
Acetona	X	A	X	A
Acido Acético 5%	B	A	A	A
10%	B	A	A	A
20%	B	A	B	A
30%	B	A	B	A
50%	C	A	C	A
Glacial 99,5%	C	B	X	A
Acido acético anhidro	X	A	X	A
Acido arsénico	B	A	A	A
Acido bromhídrico, max 40°C	C	A	B	A
Acido clorhídrico 37%	X	A	-	A
Acido clorhídrico, 37%, 70°C	X	X	X	A
Acido clorhídrico diluido	C	A	A	A
Acido clorosulfónico	X	X	C	A
Acido crómico	X	C	A	A
Acido hidrofúor-silícico, 40°C	B	A	A	A
Acido fluorhídrico 50%, 40°C	X	B	A	A
Acido fluorsilícico	B	B	A	A
Acido fórmico	X	A	X	A
Acido fosfórico 45%, 40°C	C	A	A	A
85%, 40°C	X	B	A	A
Acido láctico	A	A	A	A
Acido nítrico 20%, 40°C	X	A	A	A

COMPUESTO QUÍMICO	FORRO INTERIOR DE LA JUNTA DE EXPANSIÓN			
	NBR	EPDM	FKM	PTFE
	NITRIL	EPDM	VITON	TEFLÓN
20%, 50°C	X	B	A	A
Acido nítrico 40%, 50°C	X	C	A	A
50%, 50°C	X	X	A	A
60%, 20°C	X	X	A	A
70%, 20°C	X	X	A	A
Acido nítrico fumante	X	X	C	A
Acido oleico	A	X	A	A
Acido oxálico	C	A	B	A
Acido palmítico	A	B	A	A
Acido salicílico	B	A	A	A
Acido sulfúrico < 60%	X	B	A	A
60%, 50°C	X	B	A	A
75%, 50°C	X	B	A	A
80%, 50°C	X	C	A	A
96%, 50°C	X	C	A	A
Acido sulfúrico fumante	X	X	B	A
Acido sulfuroso	C	A	A	A
Agua destilada	A	A	A	A
Agua fría	A	A	A	A
Agua fría, destilada 100 °C	B	A	A	A
Agua residual	A	B	A	A
Agua salada	A	A	A	A
Alcohol metílico	B	A	X	-
Amonio líquido	B	A	X	A
Anilina	C	B	B	A
Argón	C	A	A	A
Azufre derretido	X	B	A	A
Benceno (benzol)	X	X	A	A
Brandy	A	A	A	A
Brea 40° C	B	X	A	A
Bromo líquido	X	X	A	A
Butano	A	X	A	A
Butanol (alcohol butílico)	A	A	A	A
Cerveza	A	A	A	A
Cloruro de azufre	X	X	A	A
Cloruro de etilo	B	A	A	A
Cloruro de metileno	X	X	B	A
Cloruro metílico	X	C	A	A
Detergente	A	A	A	A
Dióxido de azufre	X	A	A	A
Gas seco	X	A	A	A
Etano	A	X	A	A
Etanol (alcohol etílico)	A	A	B	A
Ethylene glycol	A	A	A	A
Eter de petróleo	B	X	A	A
Eter, éter etílico	C	X	X	A

COMPUESTO QUÍMICO	FORRO INTERIOR DE LA JUNTA DE EXPANSIÓN			
	NBR	EPDM	FKM	PTFE
	NITRIL	EPDM	VITON	TEFLÓN
Etilo glicol (Cellosolve)	C	B	C	A
Estireno 40° C	X	X	B	A
Fenol	X	C	A	A
Formaldehído	B	A	A	A
Fueloil	A	X	A	A
Furano	X	X	C	A
Furfurol	X	B	X	A
Gas amonia caliente	X	B	X	A
Gas amonio frío	A	A	X	A
Gas clorhídrico, húmedo, 40°C	X	C	C	A
Gas clorhídrico, seco, 40°C	X	C	A	A
Gas LP	A	X	A	A
Gas natural	A	X	A	A
Gas nitroso	X	C	X	B
Gasolina 100 oct	C	X	A	A
65 oct	B	X	A	A
Gasoil	A	X	A	A
Glicerina	A	A	A	A
Glucosa	A	A	A	A
Grasas animales	A	B	A	A
Hidrógeno	A	A	A	A
Hidróxido de amonio	C	A	B	A
Hipoclorito de calcio	C	A	A	A
Hipoclorito sódico < 10gr/l	C	A	A	A
Hipoclorito sódico > 10gr/l	X	B	A	A
Leche	A	A	A	A
Licor negro	A	X	A	A
Licor verde, licor blanco	A	A	A	A
Liquid manure	A	A	-	A
LP gas, propano	A	X	A	A
MEK Metil etil cetona	X	A	X	B
Metil isobutil cetona	X	B	X	A
Metil isopropil cetona	X	C	X	A
Nitrobenceno	X	B	B	A
Nitrógeno	A	A	A	A
Oxígeno	C	A	A	A
Ozono	X	B	A	A
Parafina de queroseno	A	X	A	A
Percloroetileno	C	X	A	A
Peróxido de hidrogeno, 3%, 40°C	B	A	A	A
30%, 20°C	C	B	A	A
90%, 20°C	C	-	B	A

COMPUESTO QUÍMICO	FORRO INTERIOR DE LA JUNTA DE EXPANSIÓN			
	NBR	EPDM	FKM	PTFE
	NITRIL	EPDM	VITON	TEFLÓN
Plating sol. W/o chromium	X	A	A	A
Potasa cáustica	C	B	C	A
Propanol, alcohol propílico	A	A	A	A
Rapeded oil	X	A	A	A
Sales férricas, no oxidantes	A	A	A	A
Sulfuro de hidrógeno, húmedo, 40°C	X	B	X	A
Sulfuro de hidrógeno, húmedo, 20° C	C	A	X	A
Sulfuro de hidrógeno, seco, 20°C	A	A	X	A
Solución de cloro 0,1 gr./l	A	A	A	A
Solución de cloro 0,1 - 1 gr./l	A	A	A	A
Solución de cloro 1-10 gr./l 40°C	B	B	-	-
Solución de cloro > 10 gr./l 40°C	C	C	-	-
Soluciones de azúcar	A	A	A	A
Soluciones de sal no oxidantes	A	A	A	A
Sosa cáustica	C	A	B	A
Turpentine	A	X	A	A
Tricloretileno 40°C	X	X	A	A
Trióxido de azufre, gas seco	X	B	A	A
Tolueno	C	X	A	A
Whisky, vino	A	A	A	A
Xileno	X	X	A	A

CÓDIGO DE CLASIFICACIÓN

- A Comportamiento excelente
- B Comportamiento bueno
- C Comportamiento regular
- X Incompatible
- Sin datos

CHEMICAL COMPOUND	INNER LINING OF THE EXPANSION JOINT			
	NBR	EPDM	FKM	PTFE
	NITRILE	EPDM	VITON	TEFLON
Hydraulic oil (petroleum)	A	X	A	A
Linseed oil	A	B	A	A
Olive oil	A	C	A	A
Petroleum oils with high aromatic content	B	X	A	A
Petroleum oils with low aromatic content	A	X	A	A
Resin oil	A	X	A	A
Oil lubrication	A	X	A	A
Transformer oil	X	X	A	A
Oil for mineral based transformers	A	X	A	A
Vegetable oils	A	X	A	A
Acetaldehyde D	X	B	A	A
Acetate	X	A	X	A
Acetate of butilo	X	B	X	A
Ethyl acetate	X	B	X	A
Acetylene	A	A	A	A
Acetone	X	A	X	A
Acetic Acid 5%	B	A	A	A
10%	B	A	A	A
20%	B	A	B	A
30%	B	A	B	A
50%	C	A	C	A
99,5% glacial	C	B	X	A
Anhydrous acetic acid	X	A	X	A
Arsenic acid	B	A	A	A
Hydrobromic acid, max 40°C	C	A	B	A
37% hydrochloric acid	X	A	-	A
37% hydrochloric acid, 70°C	X	X	X	A
Disolved hydrochloric acid	C	A	A	A
Chlorosulfonic acid	X	X	C	A
Chromic acid	X	C	A	A
Hydrofluorsilicic acid, 40°C	B	A	A	A
50% hydrofluoric acid, 40°C	X	B	A	A
Fluorsilicic Acid	B	B	A	A
Formic acid	X	A	X	A
45% phosphoric acid, 40 °C	C	A	A	A
85%, 40°C	X	B	A	A
Lactic acid	A	A	A	A
Nitric acid 20%, 40°C	X	A	A	A
20%, 50°C	B	A	A	A
40% nitric acid, 50°C	X	B	A	A

CHEMICAL COMPOUND	INNER LINING OF THE EXPANSION JOINT			
	NBR	EPDM	FKM	PTFE
	NITRILE	EPDM	VITON	TEFLON
50%, 50°C	X	X	A	A
60%, 20°C	X	X	A	A
70%, 20°C	X	X	A	A
Nitric acid smoking	X	X	C	A
Oleic acid	A	X	A	A
Oxalic acid	C	A	B	A
Palmitic acid	A	B	A	A
Salicylic acid	B	A	A	A
<60% sulfuric acid	X	B	A	A
60%, 50°C	X	B	A	A
75%, 50°C	X	B	A	A
80%, 50°C	X	C	A	A
96%, 50°C	X	C	A	A
Sulfuric Acid Smoking	X	X	B	A
Sulfurous acid	C	A	A	A
Distilled water	A	A	A	A
Cold water	A	A	A	A
Cold water, distilled 100 °C	B	A	A	A
Residual water	A	B	A	A
Saltwater	A	A	A	A
Methyl alcohol	B	A	X	-
Liquid ammonium	B	A	X	A
Aniline	C	B	B	A
Argon	C	A	A	A
Melted sulfur	X	B	A	A
Benzene (Benzol)	X	X	A	A
Brandy	A	A	A	A
40°C brea	B	X	A	A
Liquid bromine	X	X	A	A
Butane	A	X	A	A
Butanol (Butyl alcohol)	A	A	A	A
Beer	A	A	A	A
Sulfur chloride	X	X	A	A
Ethyl chloride	B	A	A	A
Methylene chloride	X	X	B	A
Methyl chloride	X	C	A	A
Detergent	A	A	A	A
Sulfur dioxide, dry gas	X	A	A	A
Ethane	A	X	A	A
Ethanol (ethyl alcohol)	A	A	B	A
Ethylene glycol	A	A	A	A
Petroleum ether	B	X	A	A
Ether, ethyl ether	C	X	X	A
Ethylene	X	C	B	A
Ethyl Glycol (Cellosolve)	C	B	C	A

CHEMICAL COMPOUND	INNER LINING OF THE EXPANSION JOINT			
	NBR	EPDM	FKM	PTFE
	NITRILE	EPDM	VITON	TEFLON
Styrene 40°C	X	X	B	A
Phenol	X	C	A	A
Formaldehyde	B	A	A	A
Fueloil	A	X	A	A
Furan	X	X	C	A
Furfurol	X	B	X	A
Hot ammonia gas	X	B	X	A
Cold ammonium gas	A	A	X	A
Hydrochloric gas, humid, 40°C	X	C	C	A
Hydrochloric gas, dry, 40°C	X	C	A	A
LP gas	A	X	A	A
Natural gas	A	X	A	A
Nitrous gas	X	C	X	B
Petrol 100 Oct	C	X	A	A
65 oct	B	X	A	A
Gasoil	A	X	A	A
Glycerin	A	A	A	A
Glucose	A	A	A	A
Animal fats	A	B	A	A
Hydrogen	A	A	A	A
Ammonium hydroxide	C	A	B	A
Calcium hypochlorite	C	A	A	A
Sodium hypochlorite <10 gr/l	C	A	A	A
Sodium hypochlorite > 10 gr/l	X	B	A	A
Milk	A	A	A	A
Black liquor	A	X	A	A
Green liquor, white liquor	A	A	A	A
Liquid manure	A	A	-	A
LP gas, propane	A	X	A	A
MEK Methyl Ethyl Ketone	A	X	X	B
Methyl isobutyl ketone	X	B	X	A
Methyl Isopropyl ketone	X	C	X	A
Nitrobenzene	X	B	B	A
Nitrogen	A	A	A	A
Oxygen	C	A	A	A
Ozone	X	B	A	A
Kerosene paraffin	A	X	A	A
Perchlorethylene	C	X	A	A
Hydrogen peroxide, 3%, 40°C	B	A	A	A
30%, 20°C	C	B	A	A
90%, 20°C	C	-	B	A
Plating sol. W/o chromium	X	A	A	A

CHEMICAL COMPOUND	INNER LINING OF THE EXPANSION JOINT			
	NBR	EPDM	FKM	PTFE
	NITRILE	EPDM	VITON	TEFLON
Caustic potash	C	B	C	A
Propanol, propyl alcohol	A	A	A	A
Rapeseed oil	X	A	A	A
Ferric salts, non-oxidizing	A	A	A	A
Hydrogen sulphide, wet, 40°C	X	B	X	A
Hydrogen sulphide, wet, 20°C	C	A	X	A
Hydrogen sulfide, dry, 20°C	A	A	X	A
Chlorine solution 0.1 gr./l	A	A	A	A
Chlorine solution 0.1 - 1 gr./l	A	A	A	A
Chlorine solution 1-10 gr./l 40°C	B	B	-	-
Chlorine solution > 10 gr./l 40°C	C	C	-	-
Sugar solutions	A	A	A	A
Non-oxidizing salt solutions	A	A	A	A
Caustic soda	C	A	B	A
Terpentine	A	X	A	A
40°C trichlorethylene	X	X	A	A
Sulfur trioxide, dry gas	X	B	A	A
Toluene	C	X	A	A
Whiskey, wine	A	A	A	A
Xylene	X	X	A	A

SORT CODE

- A Excellent behavior
- B Good behavior
- C Regular behavior
- X Incompatible
- No data

APLICACIONES VÁLVULAS INDUSTRIALES

- VALVULAS INDUSTRIALES
- INSTALACIONES
- CARACTERISTICAS DE LAS INSTALACIONES
- APLICACIONES DE VALVULAS MT A LAS INSTALACIONES

	COMPONENTES						
	REF.	PRESIÓN	TEMPERATURA	CUERPO	EJE	CIERRE	OTROS
FILTRO	5110	16	-20 a 120 - 200	Fundición Epoxi	-	EPDM - PTFE - Grafito	Tamiz inoxidable
	5125	16	0 a 80	Fundición Epoxi	-	NBR	-
VALVULAS RETENCIÓN	5142	16	0 a 80	Fundición Epoxi	-	NBR	-
	5116	16	-20 A 120	Fundición Epoxi	Inoxidable	EPDM	-
	5119	16	- 10 A 150	Inoxidable	Inoxidable	FKM	-
	5118	40	-20 a 300	Inoxidable	Inoxidable	Inoxidable	-
	5143	16	-20 A 120	Fundición Epoxi	Inoxidable	EPDM - NBR	Latón
COMPUERTA	5113	16	-20 a 120	Fundición Epoxi	Inoxidable	EPDM - NBR	Latón
	5132	16	-20 A 180	Inoxidable	Inoxidable	Inoxidable	Inoxidable
	5128	16	-20 A 180	Inoxidable	Inoxidable	PTFE	Bola inoxidable
VALVULA DE BOLA	5117	16	-20 a 180	Acero al carbono	Inoxidable	PTFE	Bola inoxidable
	0910-0917	63	-20 A 180	Inoxidable	Inoxidable	PTFE	Bola inoxidable
	0911-0912	63	-20 a 180	Inoxidable	Inoxidable	PTFE - FKM	Bola inoxidable
	5130	40	-10 a 400	Acero aleado	Inoxidable	Metálico	-
VALVULA DE GLOBO	51302	16	-10 a 400	Acero aleado	Inoxidable	Metálico	-
	5131	16	-20 a 200	Fundición Epoxi	Inoxidable	Metálico	-
	5115	10 - 16	-20 a 120	Fundición Epoxi	Inoxidable	EPDM	DI Cromado
	5114	10 - 16	-20 a 120	Fundición Epoxi	Inoxidable	EPDM	Inoxidable
	51142	10 - 16	-20 a 80	Fundición Epoxi	Inoxidable	NBR	-
MARIPOSA	51143	10 - 16	-20 a 180°C	Fundición Epoxi	Inoxidable	PTFE	-
	5144	10 - 16	-20 a 80	Fundición Epoxi	Inoxidable	NBR	Inoxidable
	5140	10 - 16	-20 a 80	Fundición Epoxi	Inoxidable	EPDM	Rilsan
	5141	10 - 16	-20 a 120	Fundición Epoxi	Inoxidable	EPDM	Inoxidable
	5145	25 - 40	-30 a 200	Fundición Epoxi	Inoxidable	PTFE	Inoxidable
MANGUITOS ELÁSTICOS	5120	16	-20 a 80-120	Acero galvanizado	-	EPDM-NBR	-
	5121	16	-20 a 80-120	Galvanizado	-	EPDM-NBR	-

APPLICATIONS INDUSTRIAL VALVES

- INDUSTRIAL VALVES
- INSTALLATIONS
- CHARACTERISTICS OF THE FACILITIES
- APPLICATIONS OF MT VALVES TO THE FACILITIES

	COMPONENTS						
	REF.	PRESSURE	TEMPERATURE	BODY	STEM	CLOSING	OTHERS
FILTER	5110	16	-20 a 120 - 200	Epoxy Casting	-	EPDM - PTFE - Graphite	Stainless sieve
	5125	16	0 a 80	Epoxy Casting	-	NBR	-
CHECK VALVES	5142	16	0 a 80	Epoxy Casting	-	NBR	-
	5116	16	-20 A 120	Epoxy Casting	Stainless	EPDM	-
	5119	16	- 10 A 150	Stainless	Stainless	FKM	-
	5118	40	-20 a 300	Stainless	Stainless	Stainless	-
	5143	16	-20 A 120	Epoxy Casting	Stainless	EPDM - NBR	Brass
GATE	5113	16	-20 a 120	Epoxy Casting	Stainless	EPDM - NBR	Brass
	5132	16	-20 A 180	Stainless	Stainless	Stainless	Stainless
	5128	16	-20 A 180	Stainless	Stainless	PTFE	Stainless ball
BALL VALVE	5117	16	-20 a 180	Aloy steel	Stainless	PTFE	Stainless ball
	0910-0917	63	-20 A 180	Stainless	Stainless	PTFE	Stainless ball
	0911-0912	63	-20 a 180	Stainless	Stainless	PTFE - FKM	Stainless ball
	5130	40	-10 a 400	Aloy steel	Stainless	Metal	-
GLOBE VALVE	51302	16	-10 a 400	Aloy steel	Stainless	Metal	-
	5131	16	-20 a 200	Epoxy Casting	Stainless	Metal	-
	5115	10 - 16	-20 a 120	Epoxy Casting	Stainless	EPDM	DI Chromed
	5114	10 - 16	-20 a 120	Epoxy Casting	Stainless	EPDM	Stainless
	51142	10 - 16	-20 a 80	Epoxy Casting	Stainless	NBR	-
BUTTERFLY	51143	10 - 16	-20 a 180°C	Epoxy Casting	Stainless	PTFE	-
	5144	10 - 16	-20 a 80	Epoxy Casting	Stainless	NBR	Stainless
	5140	10 - 16	-20 a 80	Epoxy Casting	Stainless	EPDM	Rilsan
	5141	10 - 16	-20 a 120	Epoxy Casting	Stainless	EPDM	Stainless
	5145	25 - 40	-30 a 200	Epoxy Casting	Stainless	PTFE	Stainless
RUBBER EXPANSION JOIN	5120	16	-20 a 80-120	Galvanized steel	-	EPDM-NBR	-
	5121	16	-20 a 80-120	Galvanized	-	EPDM-NBR	-

TIPO INSTALACIONES	Fluido	Temperatura	Presión
1	Aire comprimido	Aire (78%N - 21%O2 - 1% Otros)	Ambiente 8 - 10 bar
2	Contraincendios (bics o rociadores)	Agua	Ambiente 2 - 6 bar
3	Climatización calefacción	Agua o agua con glicol	4 hasta 90°C 1.5 - 5 bar
4	Energía Solar térmica (Primario)	Agua con glicol	-15 hasta 180°C 1.5 - 3 bar
5	Riego	Agua (con arena, cal etc.)	Ambiente 2 - 6 bar
6	Suministro agua para edificios	Agua mas o menos limpia	4 hasta 70°C 2 - 10 bar
7	Alimentación	Chocolate, mantequilla, mermelada, yogurt etc.	-20 hasta 90°C 1 - 20 bar
8	Vapor	Agua en estado vapor	140 hasta 250 10 - 35bar
9	Depuradoras	Agua sucia (puede contener hidrocarburos)	Ambiente 2 - 20 bar
10	Aguas fecales	Agua sucia (puede contener hidrocarburos)	10 hasta 60°C 1 - 4 bar
11	Químicos en general	Químicos	- -
12	Sólidos a granel	Pellets, comida para animales	Ambiente 1
13	Vacio	Ausencia de fluido (aire)	Ambiente <1
14	Centrales de producción energética	Varios	Variada
15	Piscinas	Agua y concentraciones elevadas de cloro o sales	15 hasta 30 1 - 1.5
16	Gases inertes	Argón, CO2, nitrógeno	- -
17	Gases comburentes	Oxígeno hidrógeno	- -
18	Gases combustibles	Gas natural (metano) - GLP (propano - butano)	- -
19	Instalaciones navales	Agua concentraciones elevadas de sal	Ambiente 2-10bar

ATENCIÓN: Este documento es solo una orientación de las aplicaciones de las válvulas industriales marca MT. Toda aplicación de una válvula deberá ser consultada con un ingeniero conocedor de la instalación que determine, el tipo de válvula mas adecuada, la compatibilidad de sus componentes con los fluidos a controlar y las condiciones de uso y ambientales. En ningún caso es un documento vinculante.

TYPE FACILITIES	Fluid	Temperature	Pressure
1	Compressed air	Air (78%N - 21%O2 - 1% Otros)	Environment 8 - 10 bar
2	Firefighting (Bics or Sprinklers)	Water	Environment 2 - 6 bar
3	Air conditioning Heating	Water or Water with glycol	4 to 90°C 1.5 - 5 bar
4	Thermal Solar Energy (Primary)	Water with glycol	-15 to 180°C 1.5 - 3 bar
5	Irrigation	Water (with sand, lime etc.)	Environment 2 - 6 bar
6	Water supplyfor buildings	More or less clean water	4 to 70°C 2 - 10 bar
7	Feeding	Chocolate, butter, jam, yogurt etc.	-20 a 90°C 1 - 20 bar
8	Steam	Steam water	140 to 250 10 - 35bar
9	Sewage treatment plants	Dirty water (may contain hydrocarbons)	Environment 2 - 20 bar
10	Sewage	Dirty water (may contain hydrocarbons)	10 to 60°C 1 - 4 bar
11	General chemicals	Chemicals	- -
12	Bulk solids	Pellets, animal food	Environment 1
13	Empty	Absence of fluid (air)	Environment <1
14	Power plants	Various	Varied
15	Swimming pools	Water and high concentrations of chlorine or salts	15 to 30 1 - 1.5
16	Inert gases	Argon, CO2, nitrogen	- -
17	Oxidizing gases	Hydrogen oxygen	- -
18	Combustible gases	Natural gas (methane) - LPG (propane - butane)	- -
19	Naval Facilities	Water high salt concentrations	Environment 2-10bar

ATTENTION: This document is only an orientation of the applications of the MT brand industrial valves. Any application of a valve must be consulted with an engineer who knows the installation that determines the most appropriate type of valve, the compatibility of its components with the fluids to be controlled and the conditions of use and environmental conditions. In no case is it a binding document.

TIPO INSTALACIONES FACILITIES TYPE	1	2	3	4	5	6	7	8	9	10	11	12	13	14	15	16	17	18	19	
FILTRO FILTER	5110	✓	✓	✓	√(*1)	✓	√(*2)	✗	√(*3)	✓	✓	-	✗	✗	√(*4)	✗	✗	✗	✗	✗
VALVULAS RETENCIÓN CHECK VALVE	5125	✗	✓	✗	✗	✓	✓	✗	✗	✓	✓	✗	√(*5)	✗	√(*4)	✗	✗	✗	✗	✗
	5142	✗	✓	✗	✗	✓	✓	✗	✗	✓	✓	✗	√(*5)	✗	√(*4)	✗	✗	✗	✗	✗
	5116	✓	✓	✓	✗	✗	✓	✗	✗	✗	✗	✗	✗	✗	√(*4)	✗	✗	✗	✗	✗
	5119	✓	✓	✓	✓	✗	✓	✓	✗	✗	✗	-	✓	✗	√(*4)	✗	✗	✗	✗	✗
	5118	✓	✓	✓	✓	✗	✓	✓	✗	✗	✗	-	✗	✗	√(*4)	✗	√(*9)	√(*9)	✗	✓
COMPUERTA GATE	5143	✗	✓	✗	✗	✓	✓	✗	✗	✓	√(*8)	-	✗	✗	√(*4)	✗	✗	✗	✗	✗
	5113	✗	✓	✗	✗	✓	✓	✗	✗	✓	√(*8)	-	✗	✗	√(*4)	✗	✗	✗	✗	✗
	5132	✗	✓	✓	✓	✗	✓	✓	✗	✓	✓	-	✓	✗	√(*4)	✗	√(*9)	√(*9)	✗	✓
VALVULA DE BOLA BALL VALVE	5128	✓	✓	✓	✓	✗	✓	✓	✗	✓	✓	-	✗	✗	√(*4)	✗	√(*9)	√(*9)	✗	✓
	5117	✓	✓	✓	✓	✗	✗	✗	✗	✓	✓	-	✗	✗	√(*4)	✗	✗	✗	✗	✗
	0910-0917	✓	✓	✓	✓	✓	✓	-	✗	✓	✓	✓	✗	✗	✓	✗	√(*9)	√(*9)	✗	✓
	0911-0912	✓	✓	✓	✓	✓	✓	-	✓	✓	✓	SO	✗	✗	✓	✗	√(*9)	√(*9)	✗	✓
VALVULA DE GLOBO GLOBE VALVE	5130	✗	✗	✗	✗	✗	✗	✗	✗	✗	✗	-	✗	✗	√(*4)	✗	✗	✗	✗	✗
	51302	✗	✗	✗	✗	✗	✗	✗	✗	✗	✗	-	✗	✗	√(*4)	✗	✗	✗	✗	✗
	5131	✗	✗	✗	✗	✗	✗	✗	✓	✗	✗	-	✗	✗	√(*4)	✗	✗	✗	✗	✗
	5115	✗	✓	✗	✗	✓	✗	✗	✗	✗	✗	-	✗	✗	√(*4)	✗	✗	✗	✗	✗
	5114	✗	✓	✓	✗	✓	✓	✗	✗	✓	√(*7)	√(*7)	-	✓	✗	√(*4)	✗	✗	✗	✗
	51142	✗	✓	✓	✗	✓	✓	✗	✗	✓	✓	-	✓	✗	√(*4)	✗	✗	✗	✗	✗
MARIPOSA BUTTERFLY	51143	✗	✗	✗	✗	✗	✗	✗	✗	✓	✓	-	✗	✗	√(*4)	✓	✗	✗	✗	✗
	5144	✗	✓	✓	✗	✓	✓	✗	✗	✓	✓	-	✓	✗	√(*4)	✗	✗	✗	✗	✗
	5140	✗	✗	✗	✗	✗	✗	✗	✗	✓	✓	-	✗	✗	√(*4)	✓	✗	✗	✗	✗
	5141	✗	✓	✓	✗	✓	✓	✗	✗	✓	✓	-	✓	✗	√(*4)	✗	✗	✗	✗	✗
	5145	✗	✗	✓	✓	✗	✗	✗	✗	✗	✗	-	✗	✗	√(*4)	✗	✗	✗	✗	✗
MANGUITOS ELÁSTICOS RUBBER EXPANSION JOIN	5120	√(*6)	✓	✓	✗	✓	✓	✗	✗	√(*7)	√(*7)	-	✓	✗	√(*4)	✗	✗	✗	✗	✗
	5121	√(*6)	✓	✓	✗	✓	✓	✗	✗	√(*7)	√(*7)	-	✓	✗	√(*4)	✗	✗	✗	✗	✗

POSIBLES PROBLEMAS POR ENTORNO

- Corrientes inducidas.
Condiciones ambientales.
Desengrase de las válvulas.
Se pueden desengrasar bajo precio.
- Se debe cambiar la junta por una de Grafito.
 - Depende de la exigencia de filtrado no cumple.
 - Se debe cambiar la junta por una de Grafito y no superar los 200°C.
 - Depende de la aplicación concreta. Libres de silicona. Se pueden desengrasar bajo precio.
 - Si con reservas del tipo de sólido.
 - Sólo la versión de NBR.
 - Versión NBR por si contienen aceites o hidrocarburos.
 - En caso de aceites e hidrocarburos su aplicación no es aconsejable.
 - Se deben de limpiar y desengrasar específicamente. Cuidado con la junta.

POSSIBLE PROBLEMS BY ENVIRONMENT

- Induced currents.
Environmental conditions.
Degreasing the valves.
You can degrease low price.
- The board must be replaced with a Graphite one.
 - Depends on filtering requirement does not meet.
 - The joint must be replaced with a Graphite one and not exceed 200°C.
 - Depends on the specific application. Silicone-free. Can be degreased at a low price.
 - If with solid type reservations.
 - Only the NBR version.
 - NBR version if they contain oils or hydrocarbons.
 - In the case of oils and hydrocarbons, it's application is not advisable.
 - Must be cleaned and degreased specifically, Take care with the seal.

COEFICIENTE DE CAUDAL Kv

Kv es el coeficiente de caudal en unidades métricas. Se define como el caudal en metros cúbicos por hora [m³/h] de agua a una temperatura de 16° celsius con una caída de presión a través de la válvula de 1 bar.

Cv es el coeficiente de caudal en unidades imperiales. Se define como el caudal en galones US por minuto [gpm] de agua a la temperatura de 60° fahrenheit con una caída de presión a través de la válvula de 1 psi.

Cuando el flujo pasa a través de una válvula o otro dispositivo restrictivo pierde una energía. El **coeficiente de caudal** es un factor de diseño que relaciona la diferencia de altura (Δh) o presión (ΔP) entre la entrada y salida de la válvula con el caudal (Q). Este coeficiente permite calcular la pérdida de presión (ΔP) en la válvula para el caudal de trabajo.

Cada válvula tiene su propio coeficiente de caudal. Éste depende de como la válvula ha sido diseñada para dejar pasar el flujo a través de ella. Por consiguiente, las mayores diferencias entre diferentes coeficientes de caudal provienen del tipo de válvula, y naturalmente de la posición de abertura de la válvula.

Puede ser importante conocer el coeficiente de caudal para poder seleccionar la válvula que se necesita en una específica aplicación. Si la válvula va a estar la mayor parte del tiempo abierta, posiblemente interesará elegir una válvula con poca pérdida de carga para poder ahorrar energía. O si se trata de una válvula de control, el rango de coeficientes de caudal en las diferentes posiciones de abertura tendrían de permitir cumplir las necesidades de regulación de la aplicación.

ESQUEMA

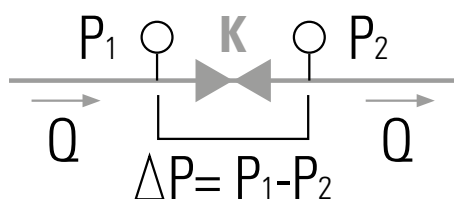

FÓRMULAS

Las fórmulas aquí referenciadas se pueden usar solo para líquidos con densidades y viscosidades cercanas a las del agua.

Equivalencia entre Kv y Cv:

$$Kv = 0.865 \cdot Cv$$

$$Cv = 1,156 \cdot Kv$$

Calculo de la pérdida de presión con caudal conocido:

$$\Delta P = \left[\frac{Q}{K} \right]^2 \cdot SG$$

Calculo del caudal con la pérdida de presión conocida:

$$Q = K \cdot \sqrt{\frac{\Delta P}{SG}}$$

Q: Caudal

ΔP: Diferencia de presión, pérdida de carga

SG: Gravedad específica (1 para agua)

K: Coeficiente de caudal Kv o Cv

SG: La gravedad específica es un numero adimensional, es decir no posee unidades. Es la relación entre la densidad de una sustancia y la densidad de otra tomada como referencia denominada sustancia patrón. Por convención, la sustancia patrón para sustancias líquidas y solidas es el agua (1), y para gases o vapores es el aire, cuya densidad en condiciones normales es 1,29 g / L.

KV FLOW COEFFICIENT

Kv is the flow coefficient in metric units. It is defined as the flow rate in cubic meters per hour [m³ / h] of water at a temperature of 16 ° Celsius with 1 bar pressure drop through the valve.

Cv is the flow coefficient in Imperial units. It is defined as the flow rate in US gallons per minute [gpm] of water at a temperature of 60 ° Fahrenheit with 1 PSI pressure drop through the valve.

When the flow passes through a valve or other restrictive device, it loses energy. The **flow coefficient** is a design factor that relates the difference in height (Δh) or pressure (ΔP) between the valve inlet and outlet with the flow rate (Q). This coefficient allows to calculate the pressure loss (ΔP) in the valve for the working flow.

Each valve has its own flow rate. It depends on how the valve has been determined to let the flow through it. In general, the greatest differences between different flow coefficients come from the type of valve, and of course from the valve opening position.

It is important to know the flow rate to be able to select the valve needed in each specific application. If the valve is going to be in open position most of the time, it may be interesting to choose a valve with little pressure loss to save energy. If it is a control valve, the range of flow coefficients in the different overture positions should allow the application regulation needs to be met.

SCHEME

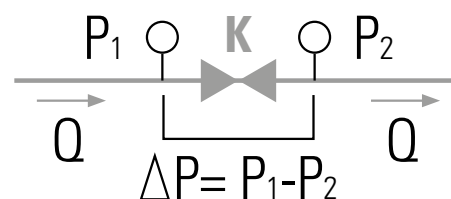

FORMULAS

The formulas here mentioned should be used only for liquids with densities and viscosities specific to those of water.

Equivalence between Kv and Cv:

$$Kv = 0.865 Cv$$

$$Cv = 1,156 Kv$$

Calculation of pressure loss with known flow:

$$\Delta P = \left[\frac{Q}{K} \right]^2 \cdot SG$$

Flow calculation with known pressure loss:

$$Q = K \cdot \sqrt{\frac{\Delta P}{SG}}$$

Q: Flow

ΔP: Pressure difference, pressure drop

SG: Specific Gravity (1 for water)

K: Flow coefficient Kv or Cv

SG: The specific gravity is a dimensionless number, that is, it has no units. It is the relationship between the density of one substance and the density of another taken as a patron. By convention, the standard substance for liquid and solid substances is water (1), and gases or steam is air, whose density under normal conditions is 1.29 g / L.

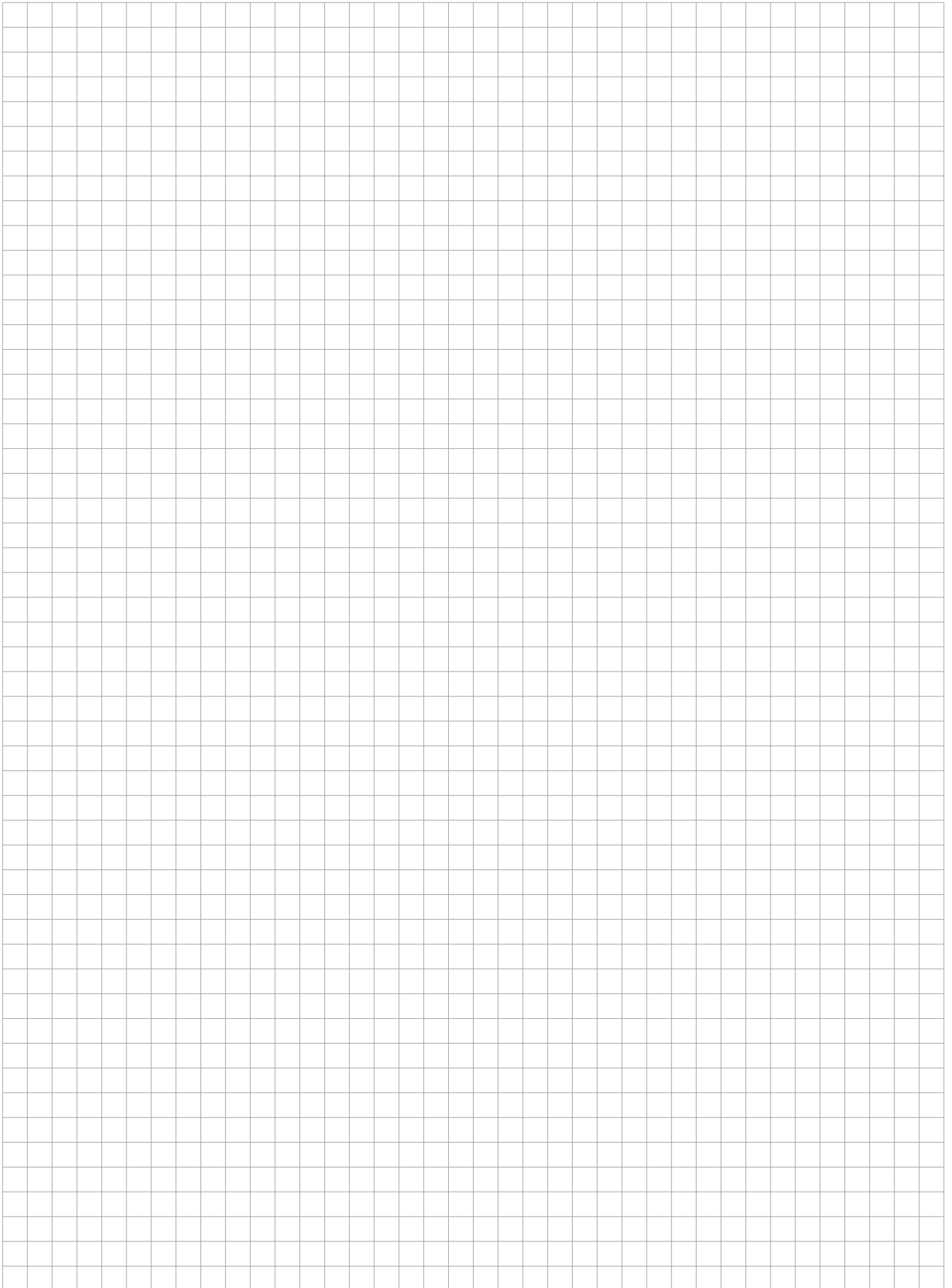

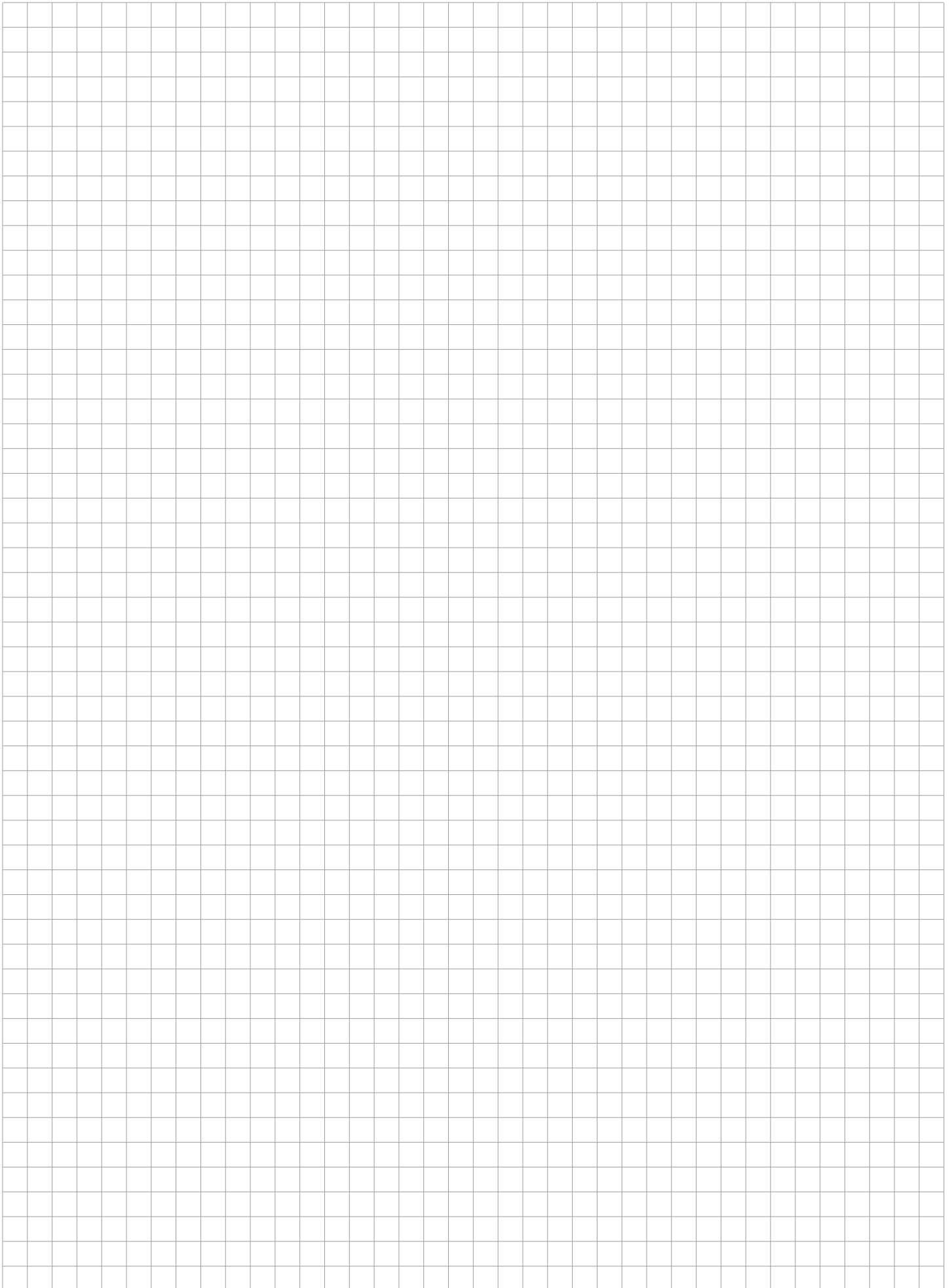



PACK DIGITAL DE DATOS DIGITAL DATA PACK



Descarga nuestro pack digital de datos para distribuidores, industriales y plataformas de venta online.

Download our digital data pack for distributors, industry and online sales platforms.



VALVES AND FITTINGS

Pol. Sector Camps d'en Ricart
C/ Comerç, 10, naves 3 a 9
08780 Pallejà, Barcelona - SPAIN
Business Key, S.L.

Tel. +34 **936 804 980**
Fax. +34 936 804 981
info@mtspain.net

mtspain.net